



ELECTRONICS

Approval



TO :
DATE : Oct. 8. 2009

SAMSUNG TFT-LCD

NOTE : Extension code [-H01]
→ LTN156AT05-**H01**
Surface type [Glare]

Any Modification of Spec is not allowed without SEC' permission.

APPROVED BY : _____

PREPARED BY : **Mia So** _____

Application Engineer part 1, Device Solution (LCD)
SAMSUNG ELECTRONICS CO., LTD



Samsung Secret

Doc.No.	LTN156AT05-H01	Rev.No	04-A00-G-091009	Page	1 / 30
---------	----------------	--------	-----------------	------	--------

CONTENTS

Revision History	----- (3)
General Description	----- (4)
1. Absolute Maximum Ratings	----- (5)
1.1 Absolute Ratings of environment	
1.2 Electrical Absolute Ratings	
2. Optical Characteristics	----- (7)
3. Electrical Characteristics	----- (10)
3.1 TFT LCD Module	
3.2 Backlight Unit	
3.3 LED Driver	
4. Block Diagram	----- (13)
4.1 TFT LCD Module	
5. Input Terminal Pin Assignment	----- (14)
5.1 Input terminal pin assignment	
5.2 LVDS Interface	
5.3 Timing Diagrams of LVDS For Transmitting	
5.4 Input Signals, Basic Display Colors and Gray Scale of Each Color.	
5.5 Pixel format	
6. Interface Timing	----- (19)
6.1 Timing Parameters	
6.2 Timing Diagrams of interface Signal	
6.3 Power ON/OFF Sequence	
7. Outline Dimension	----- (21)
8. Packing	----- (23)
9. Markings & Others	----- (24)
10. General Precautions	----- (26)
11. EDID	----- (28)

Samsung Secret



REVISION Approval

Date	Revision No.	Page	HISTORY
			Summary
Oct 08. 2009	A00	All	The approval specification of LTN156AT05-H01 was issued first.

Samsung Secret

GENERAL DESCRIPTION**DESCRIPTION**

LTN156AT05 is a color active matrix TFT (Thin Film Transistor) liquid crystal display (LCD) that uses amorphous silicon TFT as switching devices. This model is composed of a TFT LCD panel, a driver circuit and a backlight unit. The resolution of a 15.6" contains 1366 x 768 pixels and can display up to 262,144 colors. 6 O'clock direction is the optimum viewing angle.

FEATURES

- High contrast ratio
- HD (1366 x 768 pixels) resolution
- High Color Gamut (Typical 60%)
- Low power consumption
- Fast response time
- LED Back Light with embedded LED Driver
- DE (Data enable) only mode
- 3.3V LVDS Interface
- Onboard EEDID chip
- Green product (RoHS compliance)

APPLICATIONS

- Notebook PC
- If the usage of this product is not for PC application, but for others, please contact SEC

GENERAL INFORMATION

Item	Specification	Unit	Note
Display area	344.232(H) x 193.536(V) (15.6" HD diagonal)	mm	
Driver element	a-Si TFT active matrix		
Display colors	262,144		
Number of pixel	1366 x 768	pixel	16:9
Pixel arrangement	RGB vertical stripe		
Pixel pitch	0.252(H) x 0.252(V) (TYP.)	mm	
Display Mode	Normally white		
Surface treatment	Haze 0, Hard-Coating 3H		

Samsung Secret

Approval

Mechanical Information

Item		Min.	Typ.	Max.	Unit	Note
Module size	Horizontal (H)	358.8	359.3	359.8	mm	
	Vertical (V)	209.0	209.5	210.0	mm	
	Depth (D)	-	-	5.5	mm	(1)
Weight		-	430	450	g	

Note (1) Measurement condition of outline dimension
 . Equipment : Bernier Calipers
 . Push Force : 500g \oplus (minimum)

1. ABSOLUTE MAXIMUM RATINGS

1.1 ENVIRONMENTAL ABSOLUTE RATINGS

Item	Symbol	Min.	Max.	Unit	Note
Storage temperate	TSTG	-20	60	°C	(1)
Operating temperate (Temperature of glass surface)	TOPR	0	50	°C	(1)
Shock (non-operating)	Snop	-	240	G	(2),(4)
Vibration (non-operating)	Vnop	-	2.41	G	(3),(4)

Note (1) Temperature and relative humidity range are shown in the figure below.
 95 % RH Max. (40 °C ϵ Ta)
 Maximum wet - bulb temperature at 39 oC or less. (Ta > 40 °C) No condensation

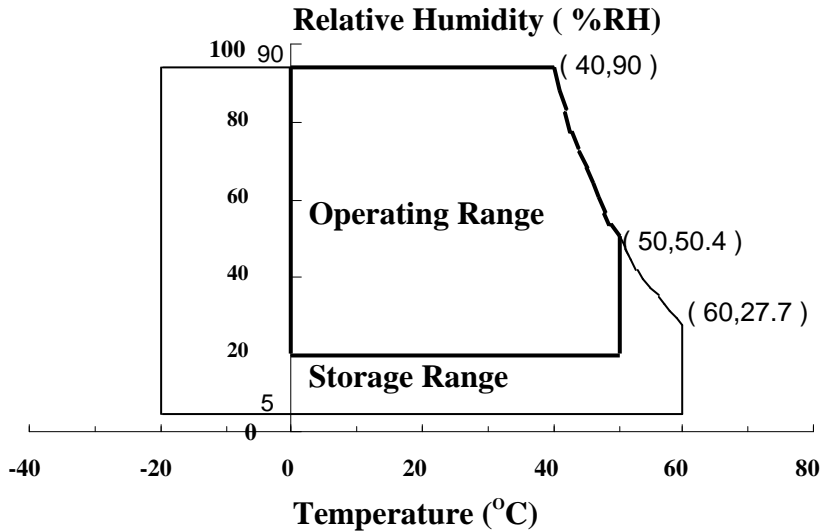

- (2) 2ms, half sine wave, one time for $\pm X, \pm Y, \pm Z$.
- (3) 5 - 500 Hz, random vibration, 30min for X, Y, Z.
- (4) At testing Vibration and Shock, the fixture in holding the Module to be tested have to be hard and rigid enough so that the Module would not be twisted or bent by the fixture.

Samsung Secret

1.2 ELECTRICAL ABSOLUTE RATINGS

(1) TFT LCD MODULE

 $V_{DD}=3.3V$, $V_{SS}=GND=0V$

Item	Symbol	Min.	Max.	Unit	Note
Power Supply Voltage	V_{DD}	$V_{DD} - 0.3$	$V_{DD} + 0.3$	V	(1)
Logic Input Voltage	V_{IN}	$V_{DD} - 0.3$	$V_{DD} + 0.3$	V	(1)

Note (1) Within T_a (25 ± 2 °C)

Samsung Secret

2. OPTICAL CHARACTERISTICS

The following items are measured under stable conditions. The optical characteristics should be measured in a dark room or equivalent state with the methods shown in Note (5).
 Measuring equipment : TOPCON SR-3

* Ta = 25 ± 2 °C, VDD=3.3V, fv= 60Hz, fDCLK = 69.3MHz, IF = 20 mA

Item	Symbol	Condition	Min.	Typ.	Max	Unit	Note	
Contrast Ratio (5 Points)	CR	Normal Viewing Angle γ = 0 λ = 0	500	-	-	-	(1), (2), (5)	
Response Time at Ta (Rising + Falling)	T _{RT}		-	16	25	msec	(1), (3)	
Average Luminance of White (5 Points)	Y _{L,AVE}		170	200	-	cd/m ²	IF=20mA (1), (4)	
Color Chromaticity (CIE)	Red		R _X	0.585	0.615	0.645	-	(1), (5) SR-3
			R _Y	0.325	0.355	0.385		
	Green		G _X	0.305	0.335	0.365		
			G _Y	0.580	0.610	0.640		
	Blue		B _X	0.120	0.150	0.180		
			B _Y	0.070	0.100	0.130		
	White		W _X	0.283	0.313	0.343		
		W _Y	0.299	0.329	0.359			
Viewing Angle	Hor.	λ _L	30	45	-	Degrees	(1), (5) SR-3	
		λ _H	30	45	-			
	Ver.	λ _H	10	15	-			
		λ _L	20	35	-			
13 Points White Variation	T _{M_L}		-	1.4	1.6	-	(6)	

Samsung Secret

Approval

Note 1) Definition of Viewing Angle : Viewing angle range(10 δ C/R)

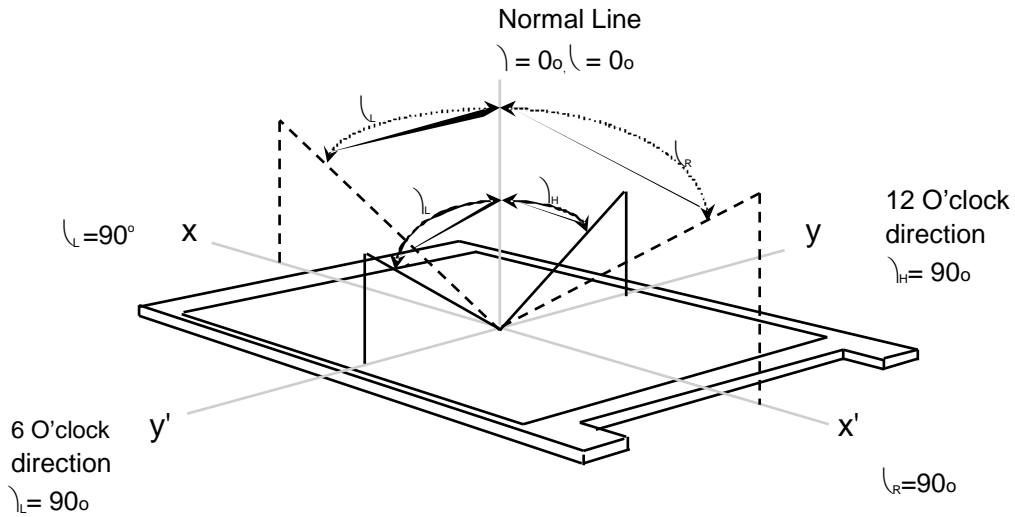

Note 2) Definition of Contrast Ratio (CR) : Ratio of gray max (Gmax) ,gray min (Gmin) at 5 points(4, 5, 7, 9, 10)

$$CR = \frac{CR(4) + CR(5) + CR(7) + CR(9) + CR(10)}{5}$$

Points  , 10 at the figure of Note (6).

Note 3) Definition of Response time :

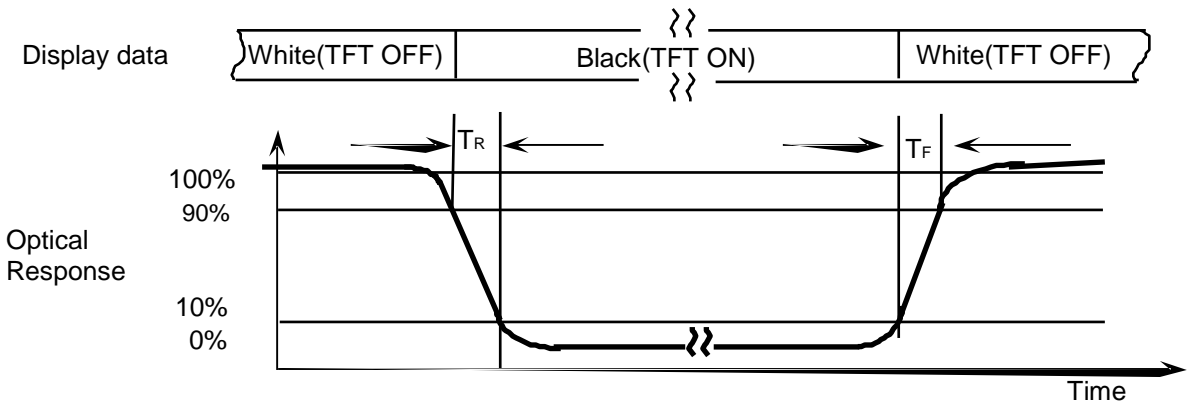

Note 4) Definition of Average Luminance of White : measure the luminance of white at 5 points.

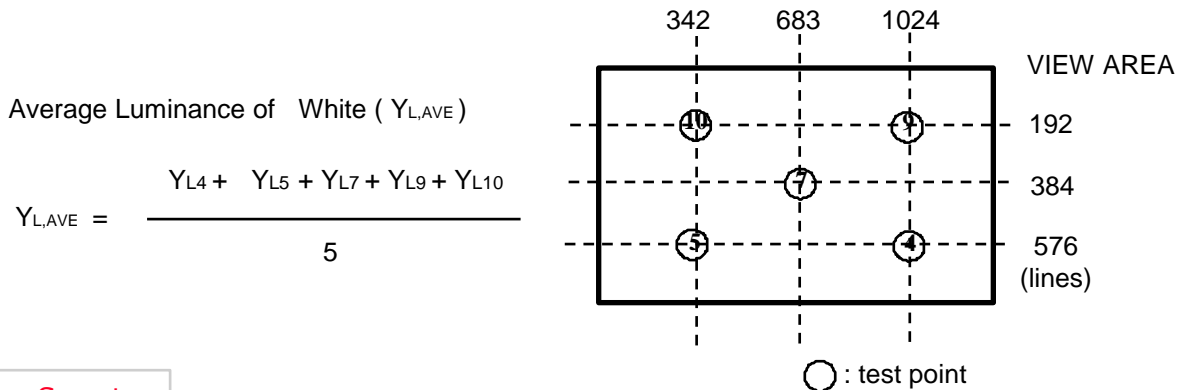

Samsung Secret

Approval

Note 5) After stabilizing and leaving the panel alone at a given temperature for 30 min , the measurement should be executed. Measurement should be executed in a stable, windless, and dark room. 30 min after lighting the backlight. This should be measured in the center of screen.

IF current : 20.0mA

Environment condition : Ta = 25 ± 2 °C

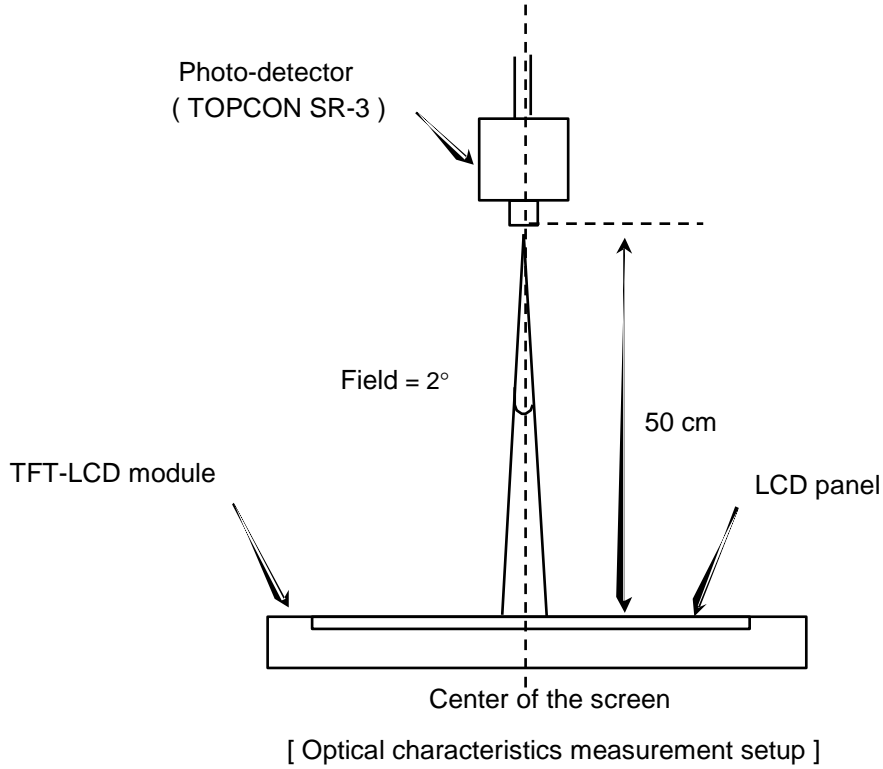

Note 6) Definition of 13 points white variation (TM_L), CR variation(C_{VER}) [○ ○~]

$$TM_L = \frac{\text{Maximum luminance of 13 points}}{\text{Minimum luminance of 13 points}}$$

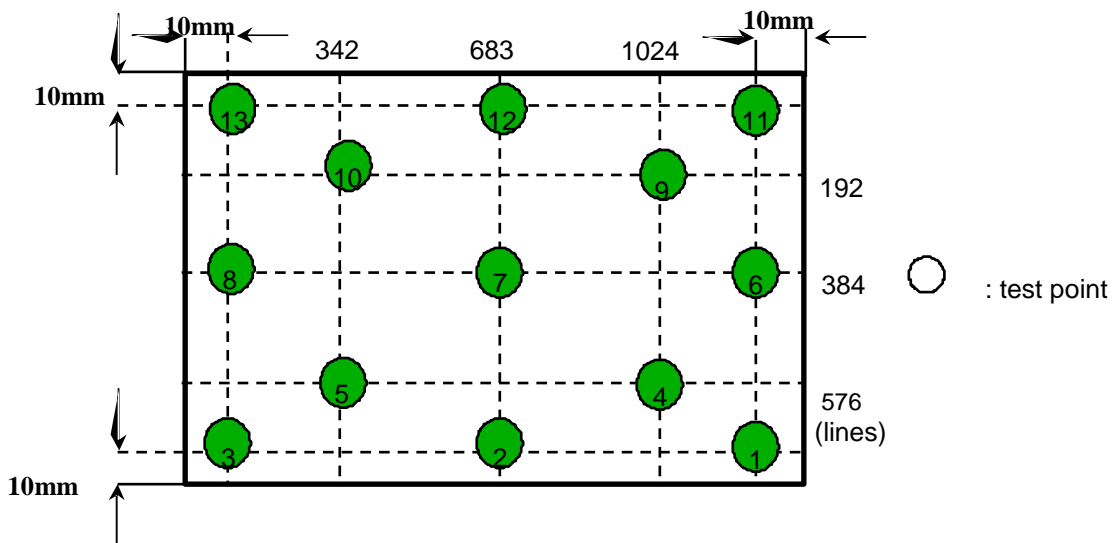

Samsung Secret

3. ELECTRICAL CHARACTERISTICS

3.1 TFT LCD MODULE

Ta= 25 ± 2°C

Item	Symbol	Min.	Typ.	Max.	Unit	Note	
Voltage of Power Supply	V _{DD}	3.0	3.3	3.6	V		
Differential Input Voltage for LVDS Receiver Threshold	High	V _{IH}	-	-	+100	mV	V _{CM} = +1.2V
	Low	V _{IL}	-100	-	-	mV	
Vsync Frequency	f _v	-	60	-	Hz		
Hsync Frequency	f _H	-	46.8	-	KHz		
Main Frequency	f _{DCLK}	67.2	69.3	70.6	MHz		
Rush Current	I _{RUSH}	-	-	1.5	A	(4)	
Current of Power Supply	White	I _{DD}	-	330	-	mA	(2),(3)*a
	Mosaic		-	470	-	mA	(2),(3)*b
	V. stripe		-	500	600	mA	(2),(3)*c

Note (1) Display data pins and timing signal pins should be connected.(GND = 0V)

(2) f_v = 60Hz, f_{DCLK} = 69.3MHz, V_{DD} = 3.3V , DC Current.

(3) Power dissipation pattern

*a) White Pattern

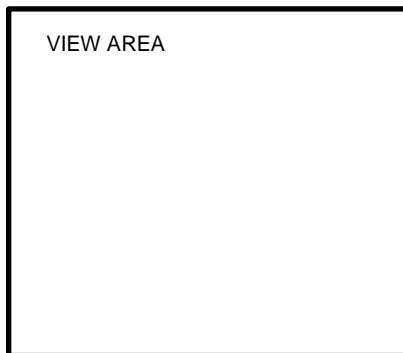

*b) Mosaic Pattern

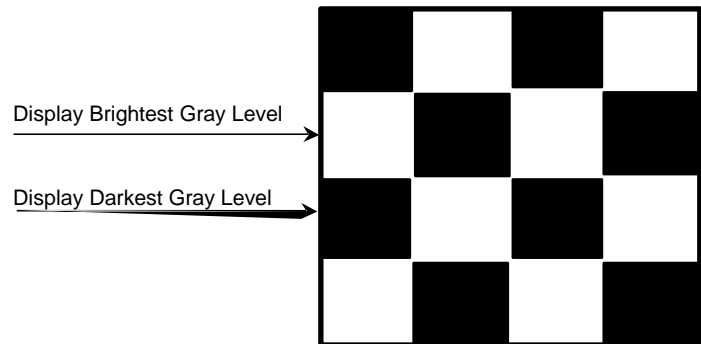

Samsung Secret

*c) 1dot Vertical stripe pattern

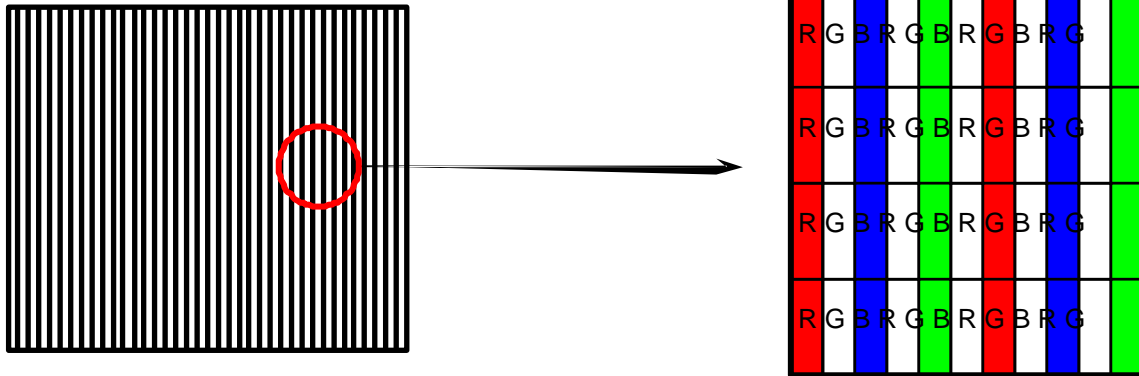

4) Rush current measurement condition

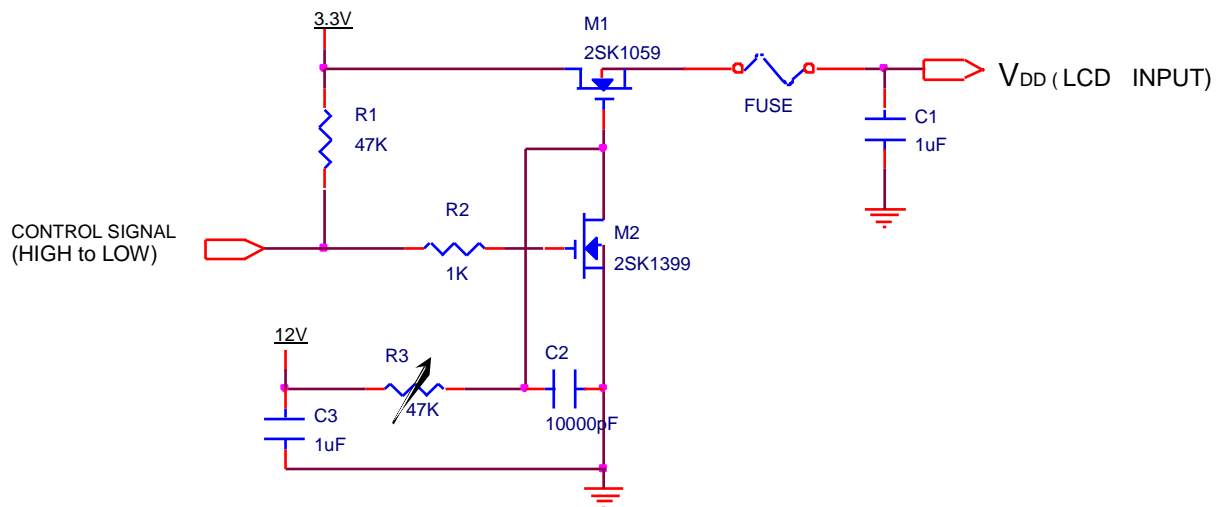

V_{DD} rising time is 470us

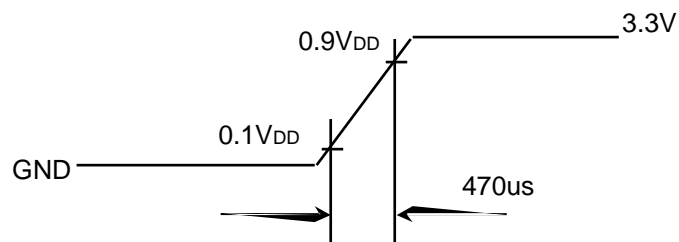

Samsung Secret

Approval

3.2 BACK-LIGHT UNIT

Ta= 25 ± 2 °C

Item	Symbol	Min.	Typ.	Max.	Unit	Note
LED Forward Current	IF	19	20	21	mA	
LED Forward Voltage	VF	-	3.2	-	V	
LED Array Voltage	VP	-	35.2	37.4	V	VF x 11 LEDs
Power Consumption	P	-	-	4.0	W	w/ Driver
Operating Life Time	Hr	12,000	-	-	Hour	(1)

Note (1) Life time (Hr) of LEDs can be defined as the time in which it continues to operate under the condition Ta= 25 ± 2 °C and IF = 20.0 mArms until one of the following event occurs.

1. When the brightness becomes 50% or lower than the original.

3.3 LED Driver

Ta= 25 ± 2 °C

Item	Symbol	Min.	Typ.	Max.	Unit	Note
Input Voltage	V _{in}	6	12	20	V	
Enable Control Level	V	0	-	5	V	ON Level : 2V~5V OFF Level : 0V ~ 0.5V
PWM Control Level	V _{PWM}	0		5	V	High Level : 2.7V~5V Low Level : 0V ~ 0.3V
PWM Control Duty Ratio	%	10	-	100	%	
PWM Input Frequency	BLIM	0.2	-	1	KHz	

Note - Test Equipment : Fluke 45

Samsung Secret

Approval

4. BLOCK DIAGRAM

4.1 TFT LCD Module

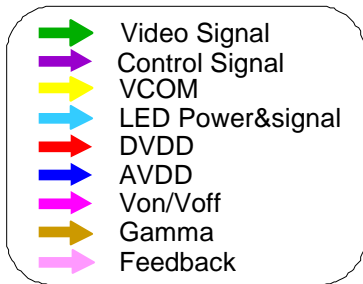
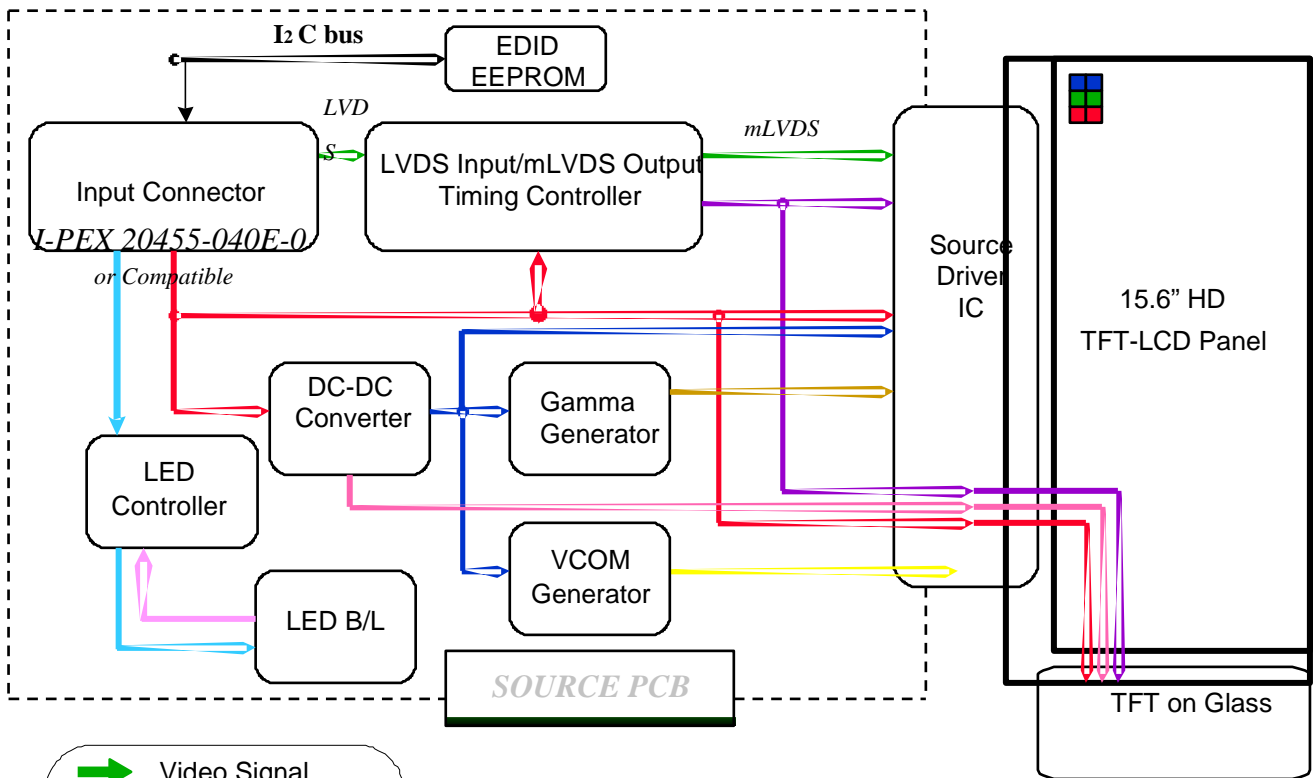

4.2 LED connection and placement

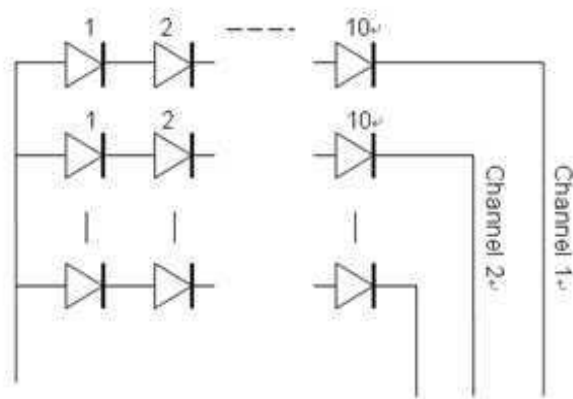

LED Wiring

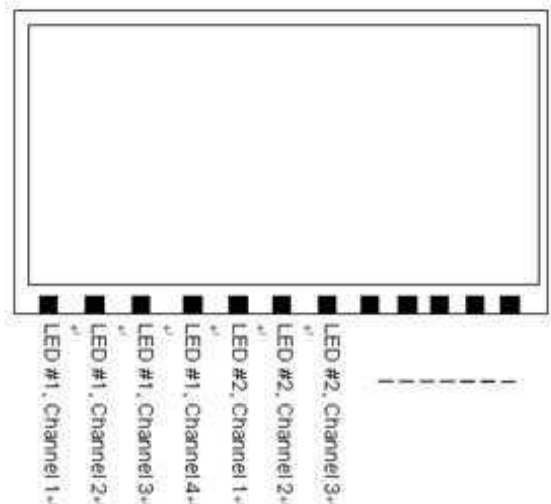

LED Placement

Samsung Secret

5. INPUT TERMINAL PIN ASSIGNMENT**5.1. Input terminal pin assignment (LVDS, Connector : 20455-040E-0 by I-PEX or equivalent)**

No.	Signal	Description
1	NC	No Connection
2~3	AVDD	Power Supply, 3.3V (typical)
4	DVDD	DDC 3.3V power
5	NC	No Connection
6	SCL	DDC Clock
7	SDA	DDC Data
8	Rin0-	-LVDS differential data input (R0-R5, G0)
9	Rin0+	+LVDS differential data input (R0-R5, G0)
10	GND	Ground
11	Rin1-	-LVDS differential data input (G1-G5, B0-B1)
12	Rin1+	+LVDS differential data input (G1-G5, B0-B1)
13	GND	Ground
14	Rin2-	-LVDS differential data input (B2-B5, HS, VS, DE)
15	Rin2+	+LVDS differential data input (B2-B5, HS, VS, DE)
16	GND	Ground
17	ClKIN-	-LVDS differential clock input
18	ClKIN+	+LVDS differential clock input
19	GND	Ground
20~21	NC	No Connection
22	GND	Ground
23~24	NC	No Connection
25	GND	Ground
26~27	NC	No Connection
28	GND	Ground
29~30	NC	No Connection
31~33	VBL-	LED Ground
34	NC	No Connection
35	BLIM	PWM for luminance control (200~1KHz, 3.3V, 10~100%)
36	BL_Enable	BL On/Off (On:2.0~3.3V, Off: 0~0.5V)
37	NC	No Connection
38~40	VBL+	LED Power Supply 6V~20V

Samsung Secret

Approval

5.2 LVDS Interface : Transmitter SN75LVDS86 or Compatible

Pin No.	Name	RGB Signal	Pin No.	Name	RGB Signal
44	TxIN0	R0	12	TxIN11	G5
45	TxIN1	R1	13	TxIN12	B0
47	TxIN2	R2	15	TxIN13	B1
48	TxIN3	R3	16	TxIN14	B2
1	TxIN4	R4	18	TxIN15	B3
3	TxIN5	R5	19	TxIN16	B4
4	TxIN6	G0	20	TxIN17	B5
6	TxIN7	G1	22	TxIN18	Hsync
7	TxIN8	G2	23	TxIN19	Vsync
9	TxIN9	G3	25	TxIN20	DE
10	TxIN10	G4	26	TxCLKIN	Clock

LVDS INTERFACE

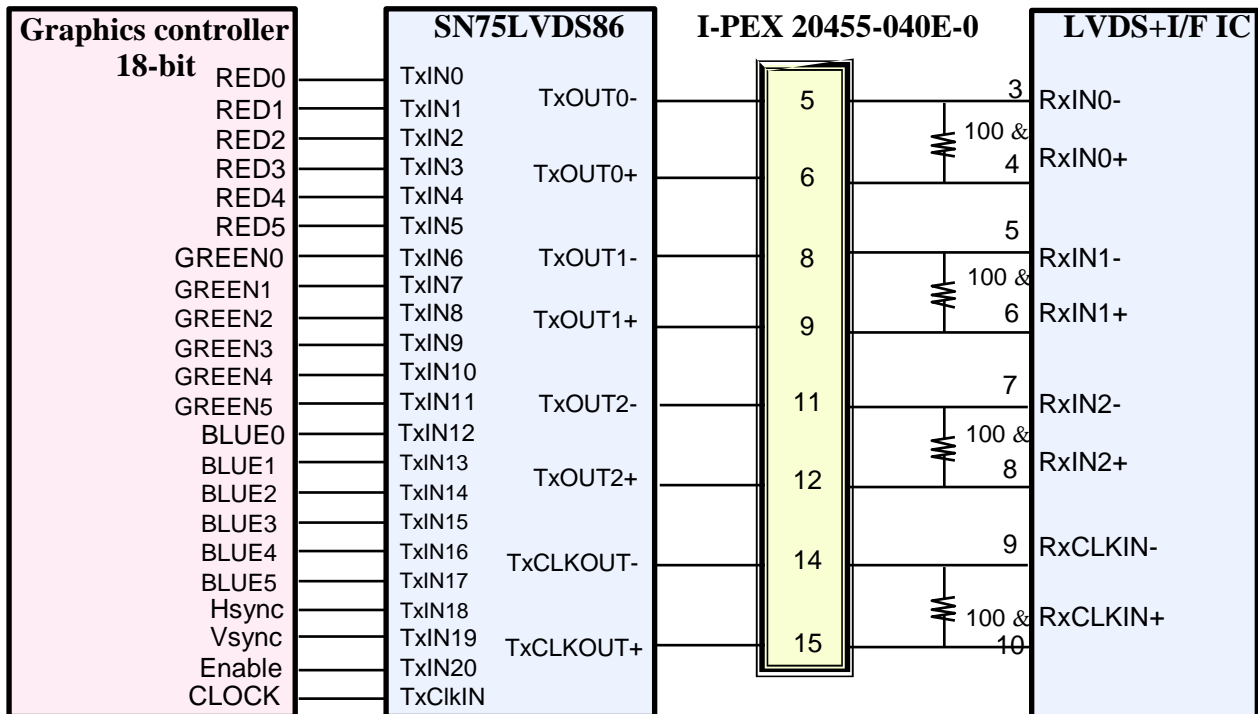

Note 1): The LCD Module uses a 100ohm resistor between positive and negative lines of each receiver input.

Samsung Secret

Approval

5.3 Timing Diagrams of LVDS For Transmission

LVDS Receiver : Integrated T-CON

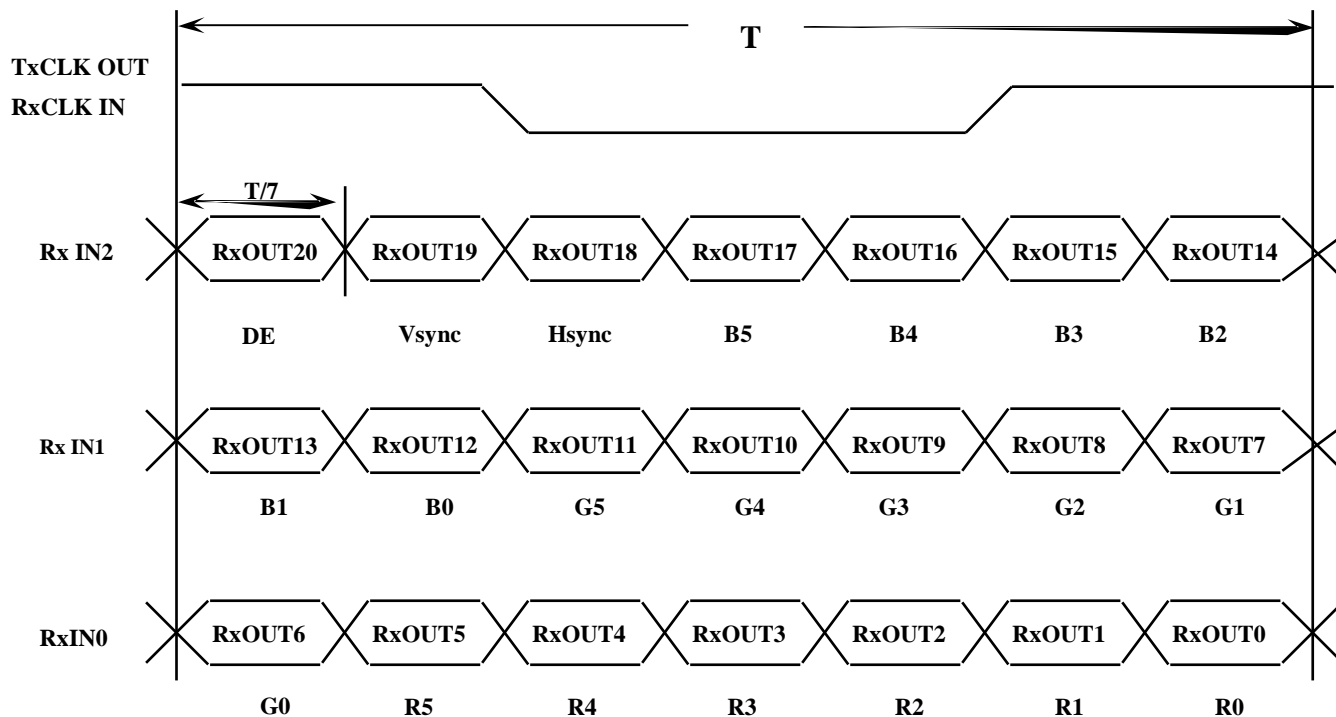

Samsung Secret

5.4 Input Signals, Basic Display Colors and Gray Scale of Each Color

Color	Display	Data Signal																Gray Scale Level	
		Red					Green					Blue							
		R0	R1	R2	R3	R4	R5	G0	G1	G2	G3	G4	G5	B0	B1	B2	B3		B4
Basic Colors	Black	0	0	0	0	0	0	0	0	0	0	0	0	0	0	0	0	0	-
	Blue	0	0	0	0	0	0	0	0	0	0	0	0	1	1	1	1	1	-
	Green	0	0	0	0	0	0	1	1	1	1	1	1	0	0	0	0	0	-
	Cyan	0	0	0	0	0	0	1	1	1	1	1	1	1	1	1	1	1	-
	Red	1	1	1	1	1	1	0	0	0	0	0	0	0	0	0	0	0	-
	Magenta	1	1	1	1	1	1	0	0	0	0	0	0	1	1	1	1	1	-
	Yellow	1	1	1	1	1	1	1	1	1	1	1	1	0	0	0	0	0	-
	White	1	1	1	1	1	1	1	1	1	1	1	1	1	1	1	1	1	-
Gray Scale Of Red	Black	0	0	0	0	0	0	0	0	0	0	0	0	0	0	0	0	R0	
	Dark	1	0	0	0	0	0	0	0	0	0	0	0	0	0	0	0	R1	
		0	1	0	0	0	0	0	0	0	0	0	0	0	0	0	0	R3<R60	
	:	:	:	:	:	:	:	:	:	:	:	:	:	:	:	:	:		
		1	0	1	1	1	1	0	0	0	0	0	0	0	0	0	0	R61	
	Light	0	1	1	1	1	1	0	0	0	0	0	0	0	0	0	0	R62	
	Red	1	1	1	1	1	1	0	0	0	0	0	0	0	0	0	0	R63	
		0	0	0	0	0	0	0	0	0	0	0	0	0	0	0	0	G3<G60	
:	:	:	:	:	:	:	:	:	:	:	:	:	:	:	:	:			
	0	0	0	0	0	0	1	0	1	1	1	1	0	0	0	0	G61		
Light	0	0	0	0	0	0	0	1	1	1	1	1	0	0	0	0	G62		
Green	0	0	0	0	0	0	1	1	1	1	1	1	0	0	0	0	G63		
Gray Scale Of Blue	Black	0	0	0	0	0	0	0	0	0	0	0	0	0	0	0	0	B0	
	Dark	0	0	0	0	0	0	0	0	0	0	0	1	0	0	0	0	B1	
		0	0	0	0	0	0	0	0	0	0	0	0	1	0	0	0	B2	
	:	:	:	:	:	:	:	:	:	:	:	:	:	:	:	:	:	B3<B60	
	:	:	:	:	:	:	:	:	:	:	:	:	:	:	:	:	:		
		0	0	0	0	0	0	0	0	0	0	0	0	1	0	1	1	B61	
	Light	0	0	0	0	0	0	0	0	0	0	0	0	0	1	1	1	B62	
	Blue	0	0	0	0	0	0	0	0	0	0	0	0	1	1	1	1	B63	

Note 1) Definition of gray :

Rn: Red gray, Gn: Green gray, Bn: Blue gray (n=gray level)

Note 2) Input signal: 0 =Low level voltage, 1=High level voltage

Samsung Secret

Approval

5.5 Pixel Format in the display

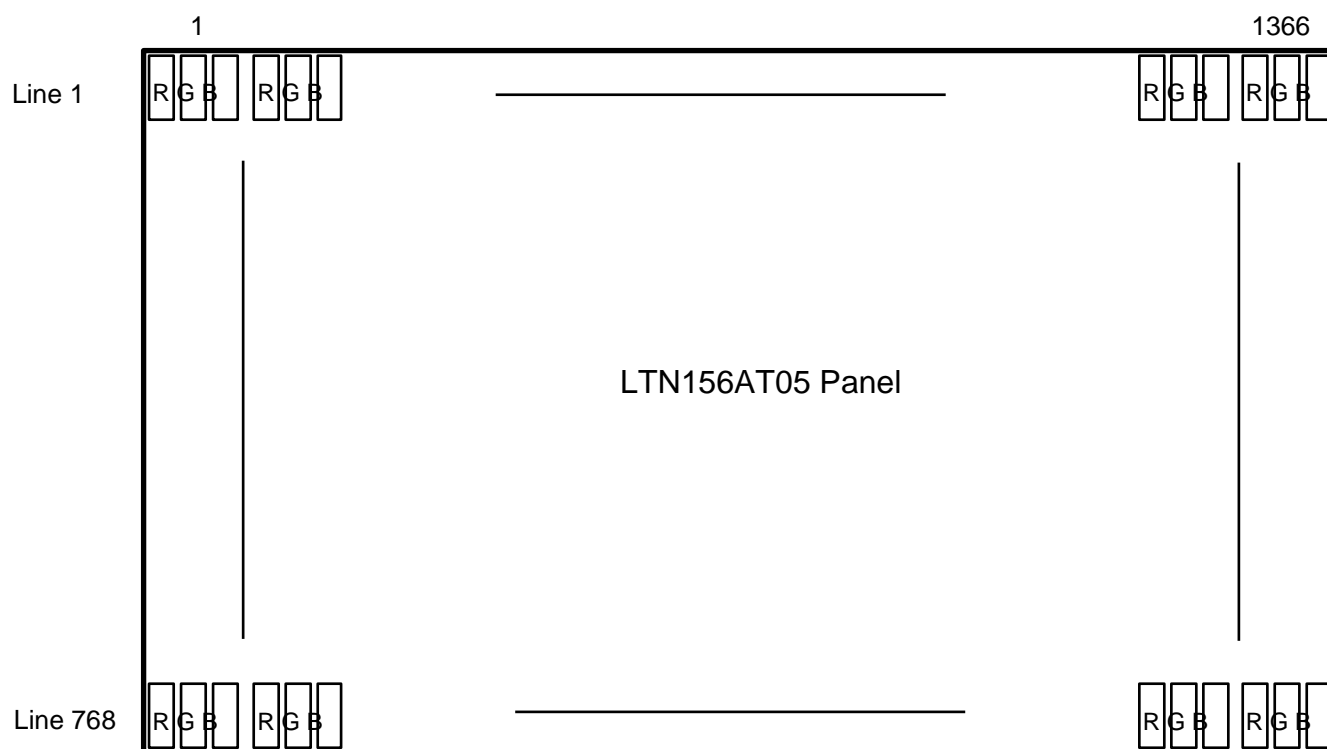

Samsung Secret

6. INTERFACE TIMING

6.1 Timing Parameters

Signal	Item	Symbol	Min.	Typ.	Max.	Unit	Note
Frame Frequency	Cycle	TV	774	780	810	Lines	
Vertical Active Display Term	Display Period	T_{VD}	-	768	-	Lines	
One Line Scanning Time	Cycle	T_H	1430	1480	1530	Clocks	
Horizontal Active Display Term	Display Period	T_{HD}	-	1366	-	Clocks	

6.2 Timing diagrams of interface signal

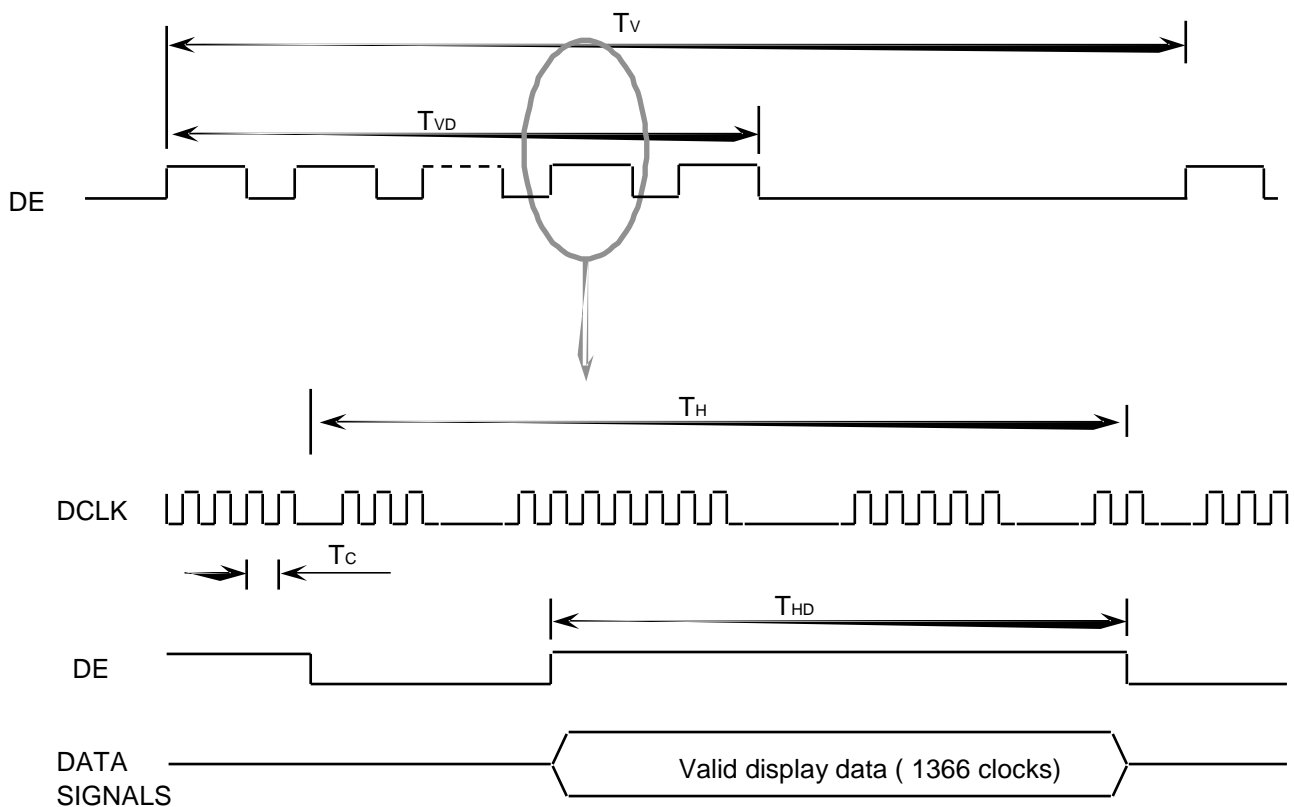

Samsung Secret

6.3 Power ON/OFF Sequence

: To prevent a latch-up or DC operation of the LCD module, the power on/off sequence should be as the diagram below.

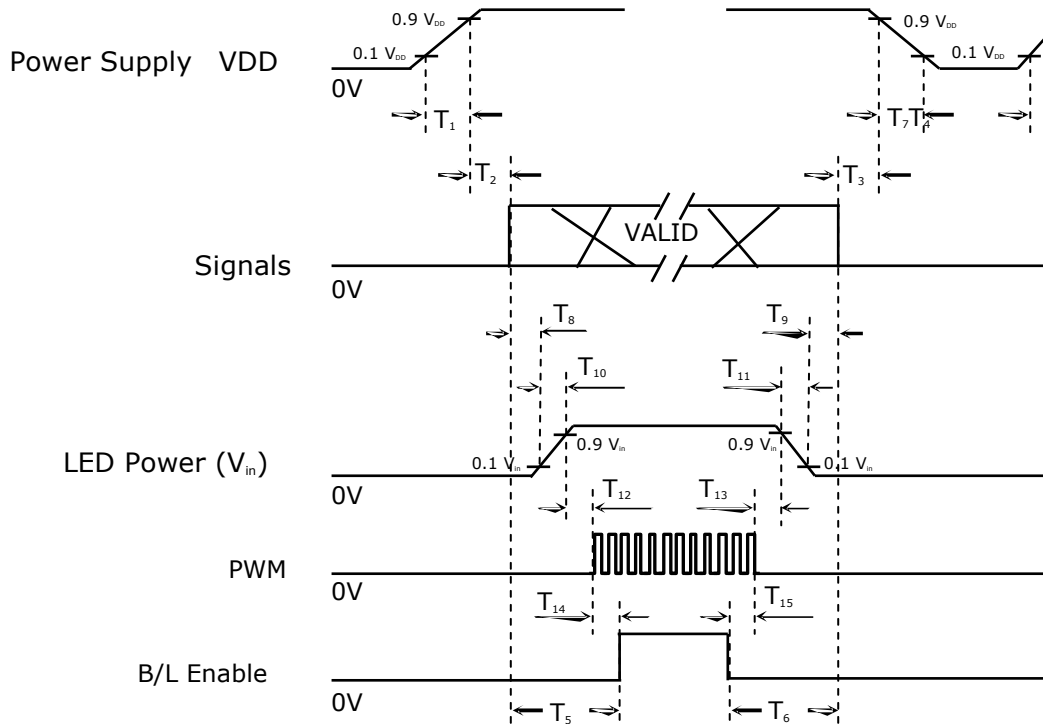

Timing (ms)	Remarks
$0.5 < T_1 \leq 10$	V_{DD} rising time from 10% to 90%
$0 < T_2 \leq 50$	Delay from V_{DD} to valid data at power ON
$0 < T_3 \leq 50$	Delay from valid data OFF to V_{DD} OFF at power Off
$500 \leq T_4$	V_{DD} OFF time for Windows restart
$200 \leq T_5$	Delay from valid data to B/L enable at power ON
$200 \leq T_6$	Delay from valid data off to B/L disable at power Off
$0 < T_7 \leq 10$	V_{DD} falling time from 90% to 10%
$10 < T_8$	Delay from valid data on to LED driver V_{in} rising time 10%
$10 < T_9$	Delay from LED driver V_{in} falling time 10% to valid data Off
$0.5 < T_{10} \leq 10$	LED V_{in} rising time from 10% to 90%
$0.5 < T_{11} \leq 10$	LED V_{in} falling time from 90% to 10%
$10 < T_{12}$	Delay from LED driver V_{in} rising time 90% to PWM ON
$10 < T_{13}$	Delay from PWM Off to LED driver V_{in} falling time 10%
$10 < T_{14}$	Delay from PWM ON to B/L Enable ON
$10 < T_{15}$	Delay from B/L Enable Off to PWM Off

Note : Backlight may flash if interface signal remains floating state at invalid period.

Samsung Secret

Approval

7. Mechanical Outline Dimension

Refer to the next page

Samsung Secret

Doc.No.	LTN156AT05-H01	Rev.No	04-A00-G-091009	Page	21 / 30
----------------	----------------	---------------	-----------------	-------------	---------

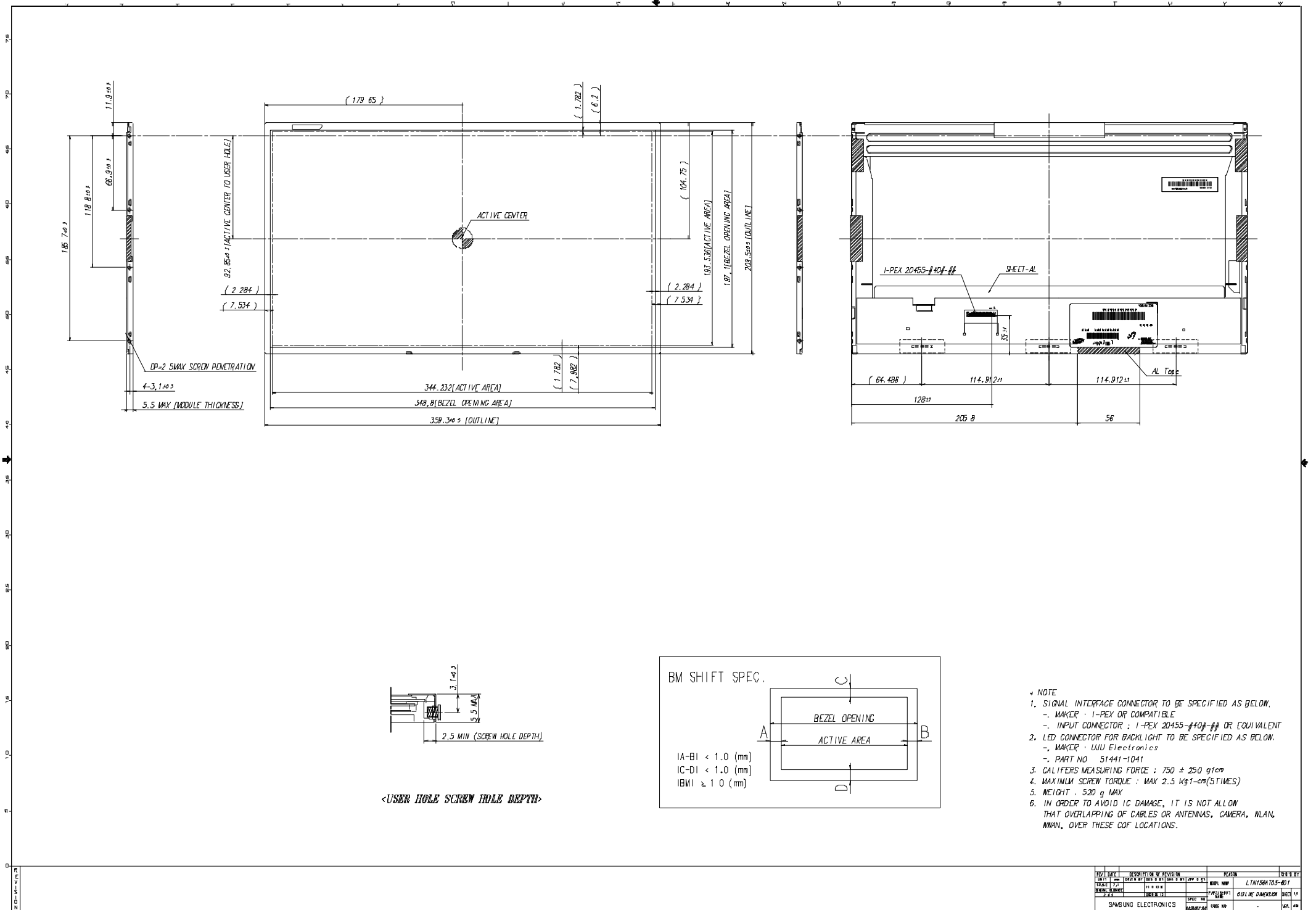

<USER HOLE SCREW HOLE DEPTH>

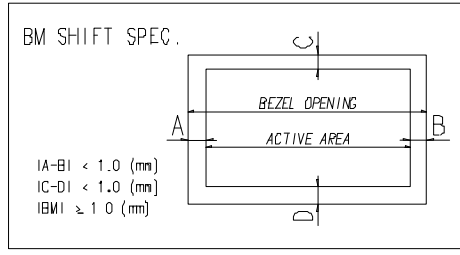

- * NOTE
- SIGNAL INTERFACE CONNECTOR TO BE SPECIFIED AS BELOW.
 - MAKER : I-PEX OR COMPATIBLE
 - INPUT CONNECTOR : I-PEX 20455-#40-## OR EQUIVALENT
 - LED CONNECTOR FOR BACKLIGHT TO BE SPECIFIED AS BELOW.
 - MAKER : LUU Electronics
 - PART NO : 51441-1041
 - CALIFERS MEASURING FORCE : 750 ± 250 gf/cm
 - MAXIMUM SCREW TORQUE : MAX 2.5 kgf-cm(5TIMES)
 - WEIGHT : 520 g MAX
 - IN ORDER TO AVOID IC DAMAGE, IT IS NOT ALLOW THAT OVERLAPPING OF CABLES OR ANTENNAS, CAMERA, WLAN, NMAN, OVER THESE COF LOCATIONS.

REV	DESCRIPTION	DATE	BY	CHK	APP
1.0	INITIAL	11.04.11
2.0
3.0
4.0
5.0
6.0
7.0
8.0
9.0
10.0
11.0
12.0
13.0
14.0
15.0
16.0
17.0
18.0
19.0
20.0
21.0
22.0
23.0
24.0
25.0
26.0
27.0
28.0
29.0
30.0
31.0
32.0
33.0
34.0
35.0
36.0
37.0
38.0
39.0
40.0
41.0
42.0
43.0
44.0
45.0
46.0
47.0
48.0
49.0
50.0
51.0
52.0
53.0
54.0
55.0
56.0
57.0
58.0
59.0
60.0
61.0
62.0
63.0
64.0
65.0
66.0
67.0
68.0
69.0
70.0
71.0
72.0
73.0
74.0
75.0
76.0
77.0
78.0
79.0
80.0
81.0
82.0
83.0
84.0
85.0
86.0
87.0
88.0
89.0
90.0
91.0
92.0
93.0
94.0
95.0
96.0
97.0
98.0
99.0
100.0

Approval

8. PACKING

1. CARTON(Internal Package)

(1) Packing Form

Corrugated Cardboard box and Corrupad form as shock absorber

(2) Packing Method

CUSHION BOTTOM

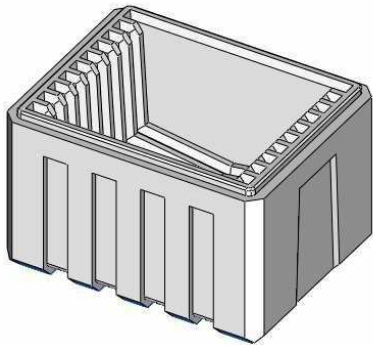

PANEL : 2EA/SLIT

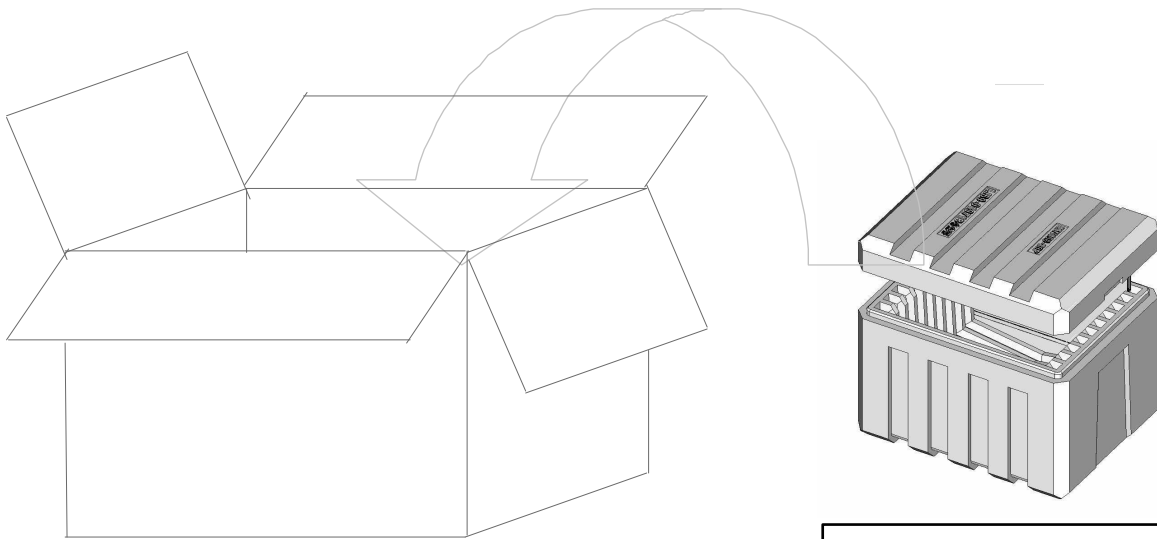
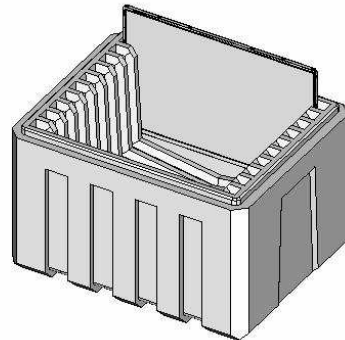

CUSHION TOP, BOTTOM

Note (1) Total : Approx. 12400g

(2) Acceptance number of piling : 20 sets

(3) Carton size : 344(W) X 432(D) X 329(H)

Samsung Secret

Approval

(3)Packing Material

No	Part name	Quantity
1	Static electric protective sack	20
2	Packing case (Inner box) included shock absorber	1 set
3	Pictorial marking	2 pcs
4	Carton	1 set

9. MARKINGS & OTHERS

A nameplate bearing followed by is affixed to a shipped product at the specified location on each product.

(1)Parts number : LTN156AT05

(2)Revision code : 3 letters

(3)Lot number : X X X X XXX XX X **H01**

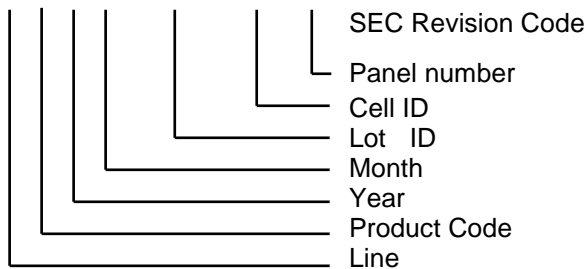

(4) Nameplate Indication

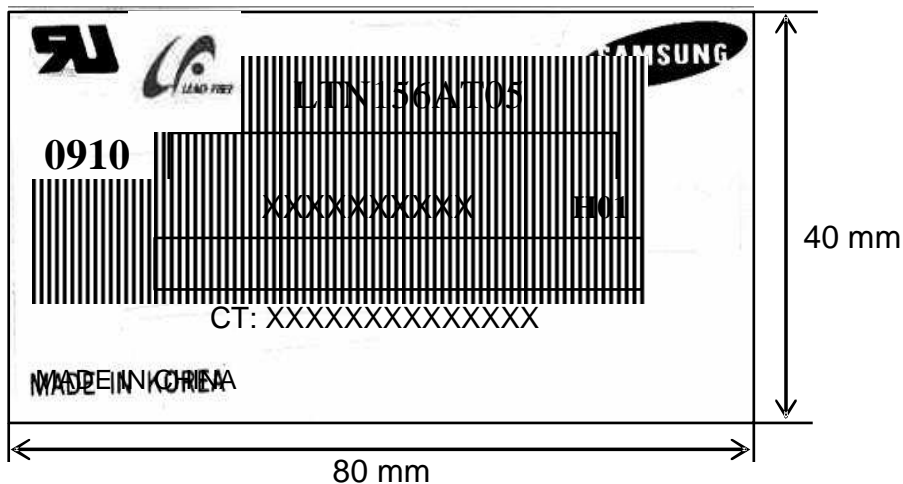

Parts name : LTN156AT05
 Lot number : XXXXXXXXXXXX
 Inspected work week : 0910 (2009 year 10rd week)
 Product Revision Code : **H01**

Samsung Secret

Approval

(5) High voltage caution notice

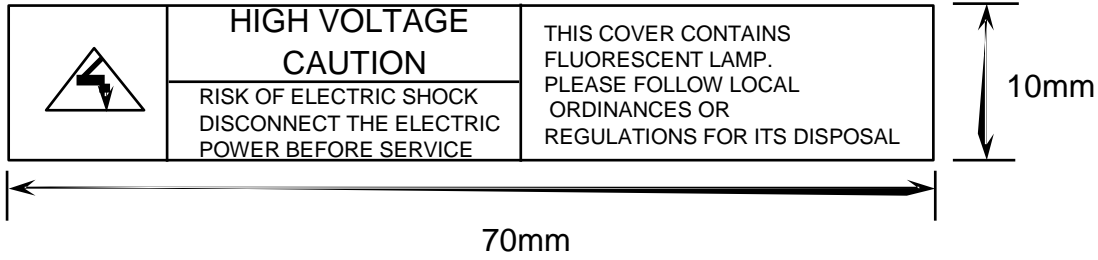

(6) Packing small box attach

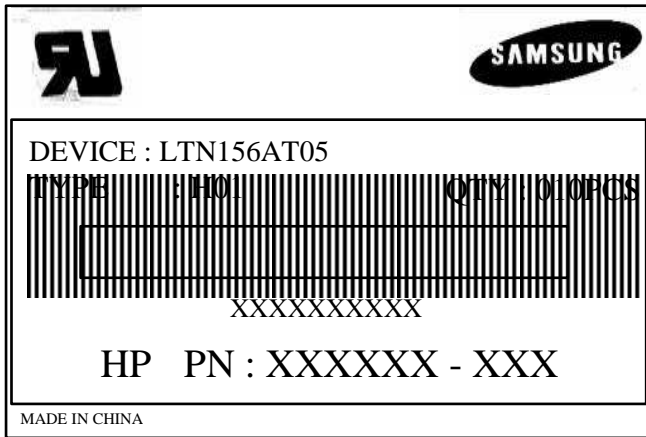

Samsung Secret

10. GENERAL PRECAUTIONS

1. Handling

- (a) When the module is assembled, It should be attached to the system firmly using every mounting holes. Be careful not to twist and bend the modules.
- (b) Refrain from strong mechanical shock and / or any force to the module. In addition to damage, this may cause improper operation or damage to the module and CCFT back-light.
- (c) Note that polarizers are very fragile and could be easily damaged. Do not press or scratch the surface harder than a HB pencil lead.
- (d) Wipe off water droplets or oil immediately. If you leave the droplets for a long time, Staining and discoloration may occur.
- (e) If the surface of the polarizer is dirty, clean it using some absorbent cotton or soft cloth.
- (f) The desirable cleaners are water, IPA (Isopropyl Alcohol) or Hexane. Do not use Ketone type materials(ex. Acetone), Ethyl alcohol, Toluene, Ethyl acid or Methyl chloride. It might permanent damage to the polarizer due to chemical reaction.
- (g) If the liquid crystal material leaks from the panel, it should be kept away from the eyes or mouth. In case of contact with hands, legs or clothes, it must be washed away thoroughly with soap.
- (h) Protect the module from static, it may cause damage to the C-MOS Gate Array IC.
- (i) Use fingerstalls with soft gloves in order to keep display clean during the incoming inspection and assembly process.
- (j) Do not disassemble the module.
- (k) Do not pull or fold the lamp wire.
- (l) Do not adjust the variable resistor which is located on the back side.
- (m) Protection film for polarizer on the module shall be slowly peeled off just before use so that the electrostatic charge can be minimized.
- (n) Pins of I/F connector shall not be touched directly with bare hands.

Samsung Secret

Doc.No.	LTN156AT05-H01	Rev.No	04-A00-G-091009	Page	26 / 30
----------------	----------------	---------------	-----------------	-------------	---------

2. STORAGE

- (a) Do not leave the module in high temperature, and high humidity for a long time.
It is highly recommended to store the module with temperature from 0 to 35 °C and relative humidity of less than 70%.
- (b) Do not store the TFT-LCD module in direct sunlight.
- (c) The module shall be stored in a dark place. It is prohibited to apply sunlight or fluorescent light during the store.

3. OPERATION

- (a) Do not connect, disconnect the module in the “Power On” condition.
- (b) Power supply should always be turned on/off by following item 6.3 “Power on/off sequence”.
- (c) Module has high frequency circuits. Sufficient suppression to the electromagnetic interference shall be done by system manufacturers. Grounding and shielding methods may be important to minimize the interference.
- (d) The standard limited warranty is only applicable when the module is used for general notebook applications. If used for purposes other than as specified, SEC is not to be held reliable for the defective operations. It is strongly recommended to contact SEC to find out fitness for a particular purpose.

4. OTHERS

- (a) Ultra-violet ray filter is necessary for outdoor operation.
- (b) Avoid condensation of water. It may result in improper operation or disconnection of electrode.
- (c) Do not exceed the absolute maximum rating value. (the supply voltage variation, input voltage variation, variation in part contents and environmental temperature, so on)
Otherwise the module may be damaged.
- (d) If the module displays the same pattern continuously for a long period of time, it can be the situation when the image “sticks” to the screen.
- (e) This module has its circuitry PCB's on the rear side and should be handled carefully in order not to be stressed.

Samsung Secret

11. EDID

Approval

Address (HEX)	FUNCTION	Value	BIN	DEC	ASCII or Data	Notes
		HEX				
00	Header	00	00000000	0		EDID Header
01		FF	11111111	255		
02		FF	11111111	255		
03		FF	11111111	255		
04		FF	11111111	255		
05		FF	11111111	255		
06		FF	11111111	255		
07		00	00000000	0		
08	ID Manufacturer Name	4C	01001100	76	S	3 character ID
09		A3	10100011	163	E C	"SEC"
0A	ID Product Code	51	01010001	81	[Q]	
0B		36	00110110	54	[6]	
0C	32-bit serial no.	00	00000000	0		
0D		00	00000000	0		
0E		00	00000000	0		
0F		00	00000000	0		
10	Week of manufacture	00	00000000	0		
11	Year of manufacture	12	00010010	18	2008	2008
12	EDID Structure Ver.	01	00000001	1	1	EDID Ver. 1.0
13	EDID revision #	03	00000011	3	3	EDID Rev. 3
14	Video input definition	80	10000000	128		
15	Max H image size	22	00100010	34	34	34 cm(approx)
16	Max V image size	13	00010011	19	19	19 cm(approx)
17	Display Gamma	78	01111000	120	2.2	Gamma 2.2
18	Feature support	0A	00001010	10		
19	Red/green low bits	87	10000111	135		10000111
1A	Blue/white low bits	F5	11110101	245		11111110
1B	Red x/ high bits	94	10010100	148	0.580	Red x 0.580= 1001010010
1C	Red y	57	01010111	87	0.340	Red y 0.340= 0101011100
1D	Green x	4F	01001111	79	0.310	Green x 0.310= 0100111101
1E	Green y	8C	10001100	140	0.550	Green y 0.550= 1000110011
1F	Blue x	27	00100111	39	0.155	Blue x 0.155= 0010011111
20	Blue y	27	00100111	39	0.155	Blue y 0.155= 0010011111
21	White x	50	01010000	80	0.313	White x 0.313= 0101000001
22	White y	54	01010100	84	0.329	White y 0.329= 0101010001
23	Established timing 1	00	00000000	0		
24	Established timing 2	00	00000000	0		
25	Established timing 3	00	00000000	0		

Samsung Secret

Approval

26	Standard timing #1	01	00000001	1		not used	
27		01	00000001	1			
28	Standard timing #2	01	00000001	1		not used	
29		01	00000001	1			
2A	Standard timing #3	01	00000001	1		not used	
2B		01	00000001	1			
2C	Standard timing #4	01	00000001	1		not used	
2D		01	00000001	1			
2E	Standard timing #5	01	00000001	1		not used	
2F		01	00000001	1			
30	Standard timing #6	01	00000001	1		not used	
31		01	00000001	1			
32	Standard timing #7	01	00000001	1		not used	
33		01	00000001	1			
34	Standard timing #8	01	00000001	1		not used	
35		01	00000001	1			
36	Detailed timing/monitor descriptor #1	12	00010010	18	69.3	Main clock= 69.3 MHz	
37		1B	00011011	27			
38		56	01010110	86	1366	Hor active=1366 pixels	
39		72	01110010	114	114	Hor blanking=114 pixels	
3A		50	01010000	80		4bit : 4bit	
3B		00	00000000	0	768	Vertical active=768 lines	
3C		0C	00001100	12	12	Vertical blanking=12 lines	
3D		30	00110000	48		4bit : 4bit	
3E		30	00110000	48	48	H sync. Offset=48 pixels	
3F		20	00100000	32	32	H sync. Width=32 pixels	
40		25	00100101	37	2 5	V sync. Offset=2 lines V sync. Width=5 lines	
41		00	00000000	0		2bit : 2bit :2bit :2bit	
42		58	01011000	88	344	H image size= 344 mm(approx)	
43		C2	11000010	194	194	V image size = 194 mm(approx)	
44		10	00010000	16			
45		00	00000000	0		No Horizontal Border	
46	00	00000000	0		No Vertical Border		
47	19	00011001	25				
48	Detailed timing/monitor descriptor #2	00	00000000	0		Manufacturer Specified (Timing)	
49		00	00000000	0			
4A		00	00000000	0			
4B		0F	00001111	15			
4C		00	00000000	0		Value=HSPWmin / 2	
4D		00	00000000	0		Value=HSPWmax / 2	
4E		00	00000000	0		Value=Thbpmin / 2	
4F		00	00000000	0		Value=Thbpmax / 2	
50		00	00000000	0		Value=VSPWmin / 2	
51		00	00000000	0		Value=VSPWmax / 2	
52		00	00000000	0		Value=TVbpmin / 2	
53		00	00000000	0		Value=TVbpmax / 2	
54		00	00000000	0		Thpmin=value*2 + HA pixelclks	
55		1E	00011110	30		Thpmax=value*2 + HA pixelclks	
56		B4	10110100	180		Tvpmin=value*2 + VA lines	
57		02	00000010	2		Tvpmax=value*2 + VA lines	
58	74	01110100	116		Module revision		
59	00	00000000	0				

Samsung Secret

Doc.No.

LTN156AT05-H01

Rev.No

04-A00-G-091009

Page

29 / 30

Approval

5A	Detailed timing/monitor descriptor #3	00	00000000	0		ASCII Data String Tag
5B		00	00000000	0		
5C		00	00000000	0		
5D		FE	11111110	254		
5E		00	00000000	0		
5F		53	01010011	83	[S]	
60		41	01000001	65	[A]	
61		4D	01001101	77	[M]	
62		53	01010011	83	[S]	
63		55	01010101	85	[U]	
64		4E	01001110	78	[N]	
65		47	01000111	71	[G]	
66		0A	00001010	10	[^]	
67		20	00100000	32	[]	
68		20	00100000	32	[]	
69		20	00100000	32	[]	
6A	20	00100000	32	[]		
6B	20	00100000	32	[]		
6C	Detailed timing/monitor descriptor #4	00	00000000	0		Monitor Name Tag (ASCII)
6D		00	00000000	0		
6E		00	00000000	0		
6F		FE	11111110	254		
70		00	00000000	0		
71		31	00110001	49	[1]	
72		35	00110101	53	[5]	
73		36	00110110	54	[6]	
74		41	01000001	65	[A]	
75		54	01010100	84	[T]	
76		30	00110000	48	[0]	
77		35	00110101	53	[5]	
78		2D	00101101	45	[-]	
79		48	01001000	72	[H]	
7A		30	00110000	48	[0]	
7B		31	00110001	49	[1]	
7C	0A	00001010	10	[^]		
7D	20	00100000	32	[]		
7E	Extension Flag	00	00000000	0		
7F	Checksum	15	00010101	21		

Samsung Secret