

10. Schematic Diagrams

10.1 Main Board(1/4)

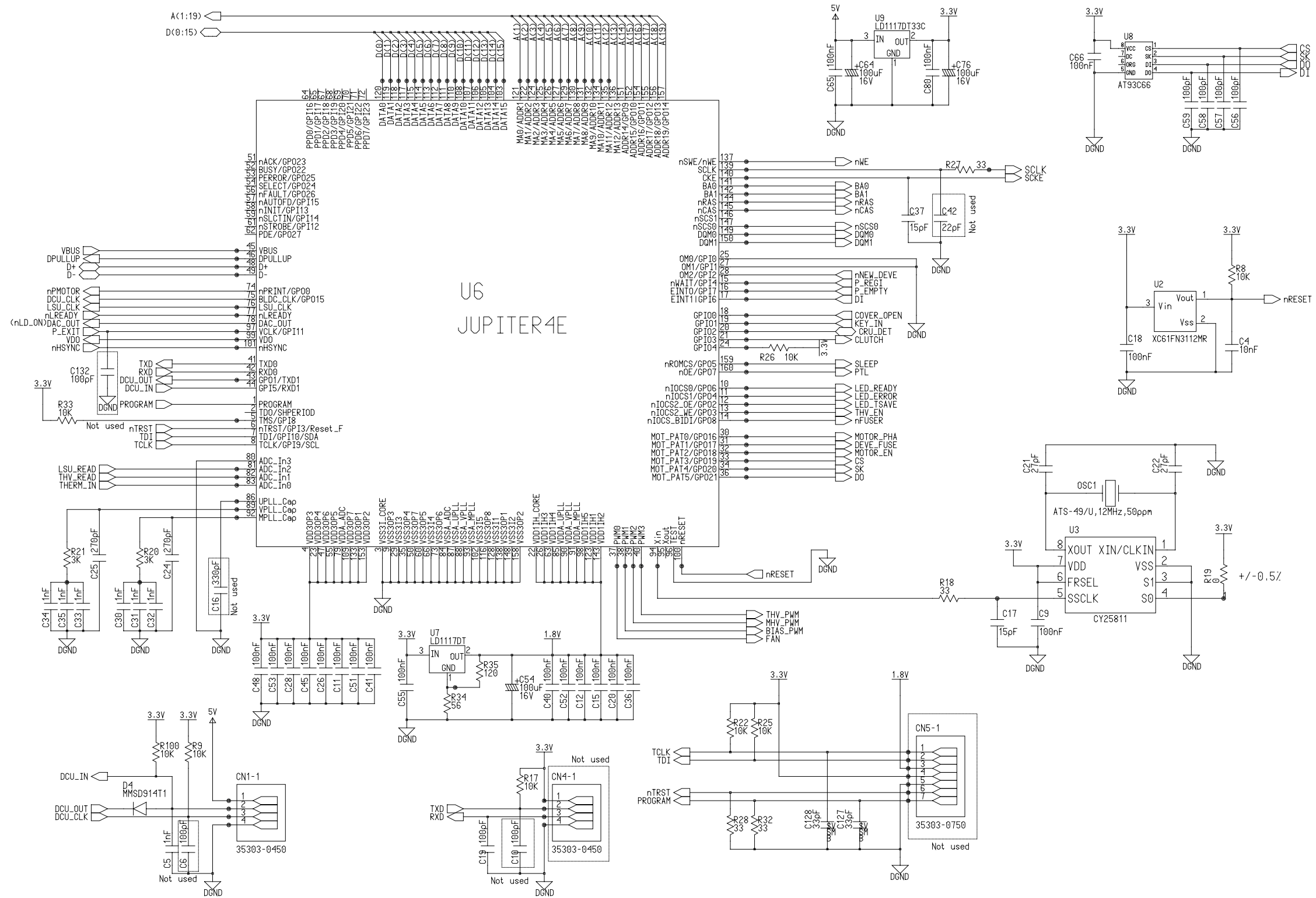

Main Board(2/4)

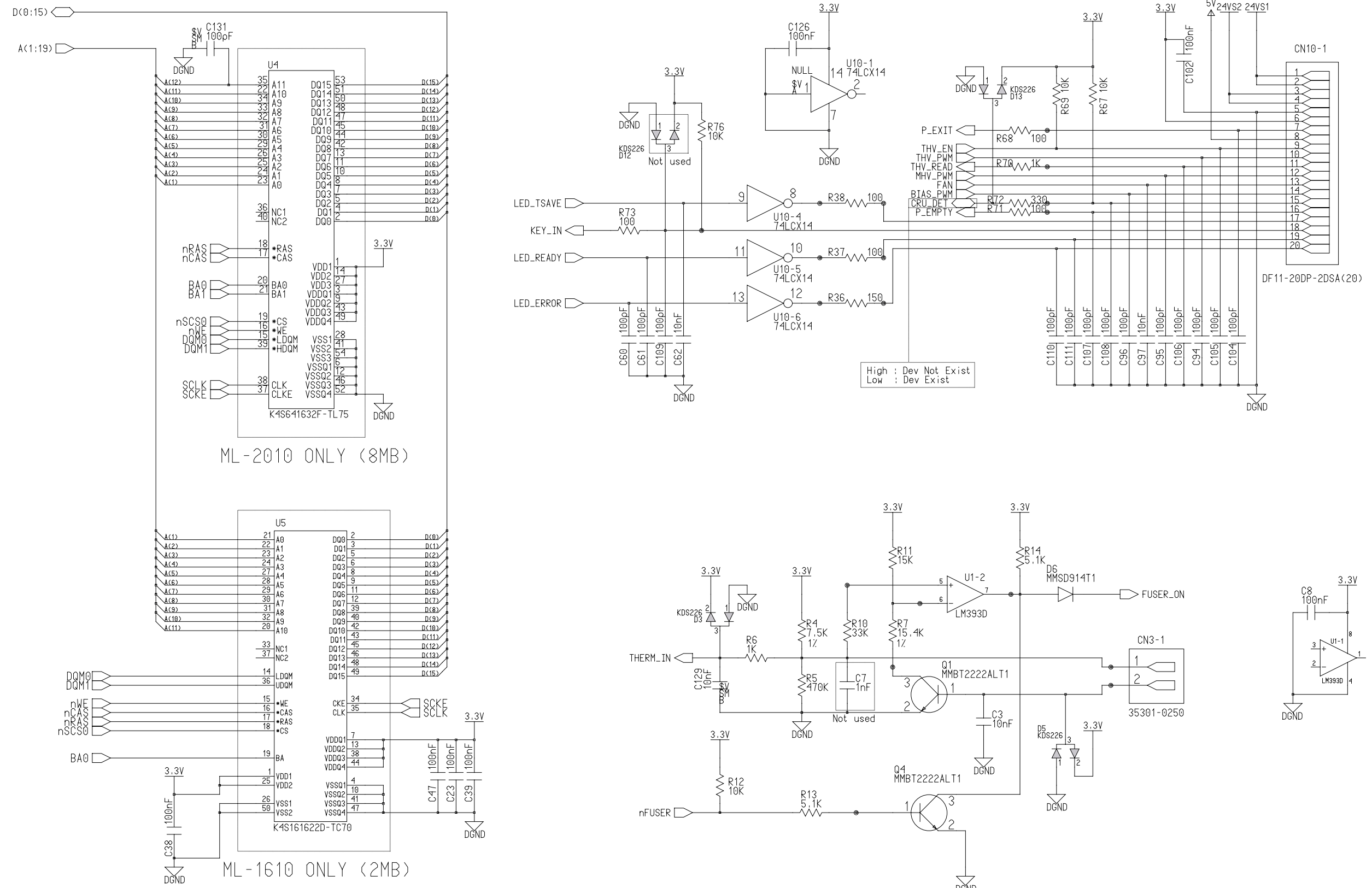

Main Board(3/4)

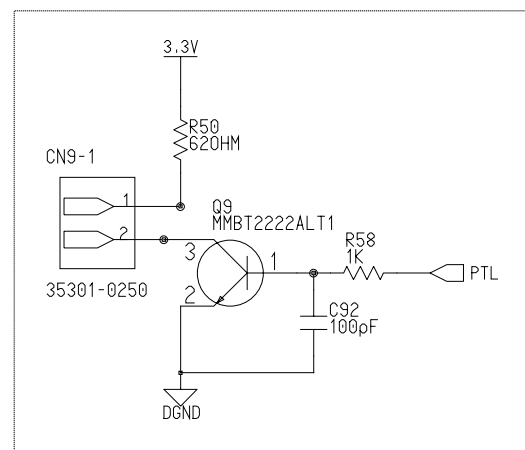
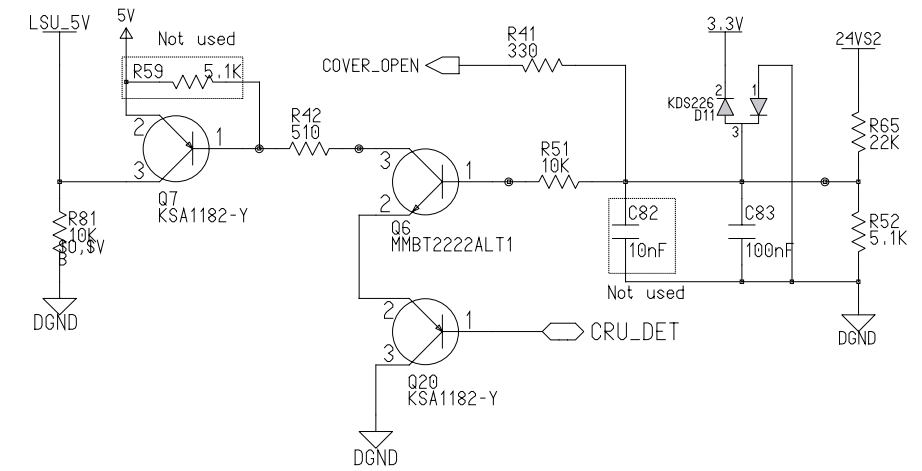
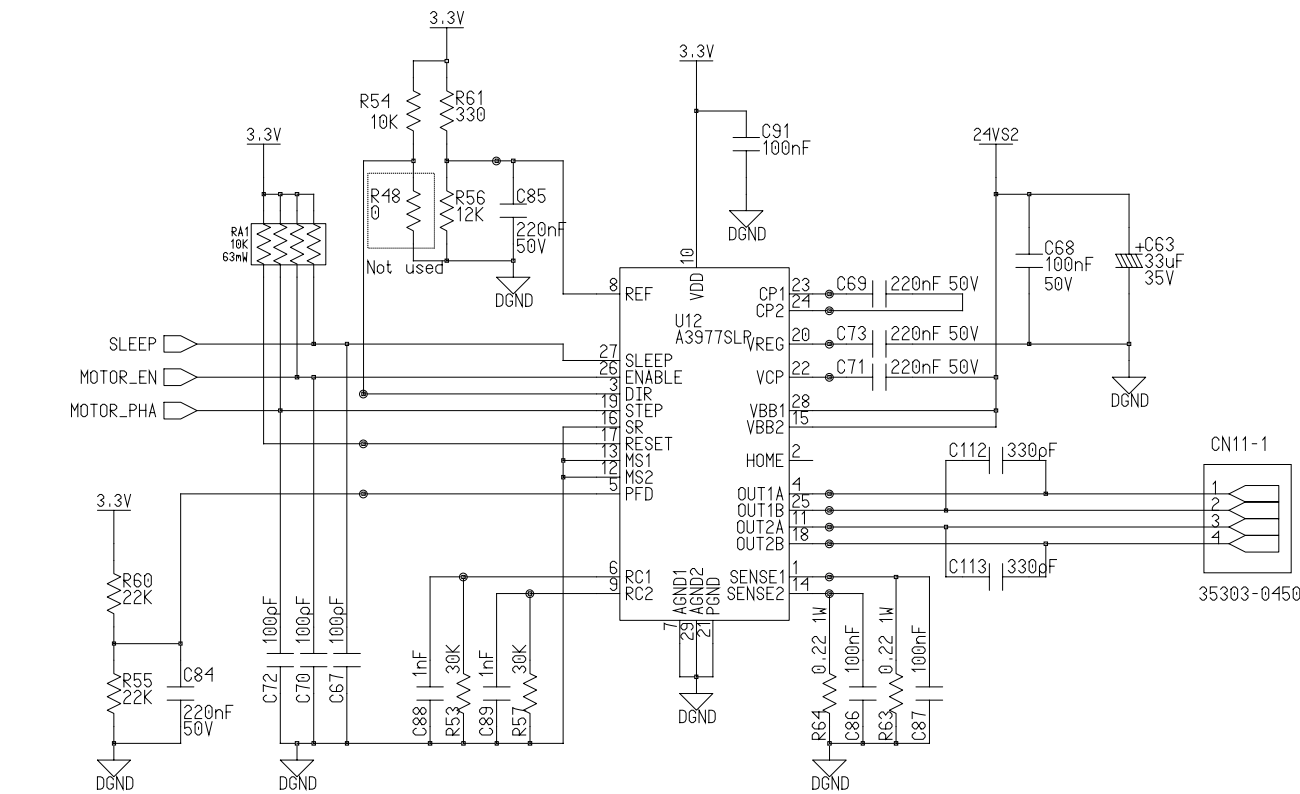

Not used

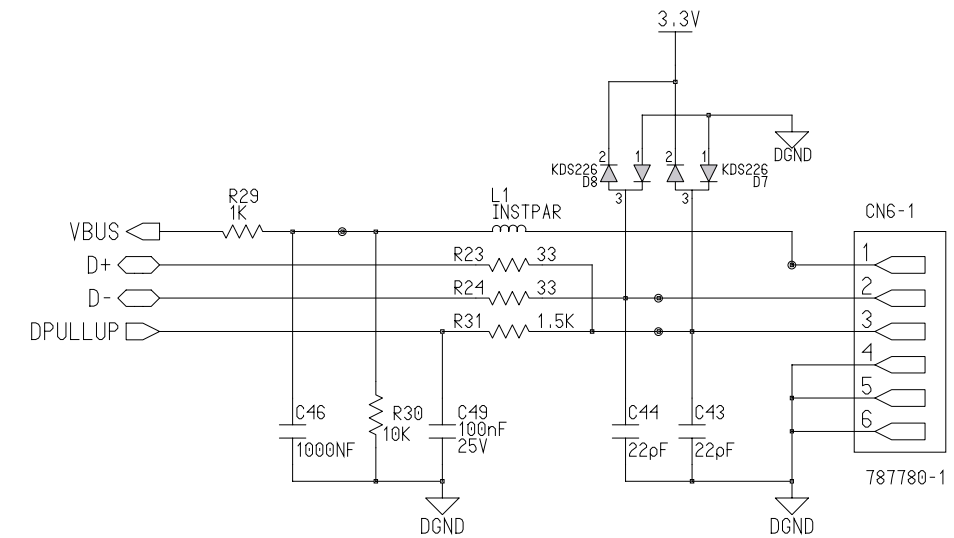
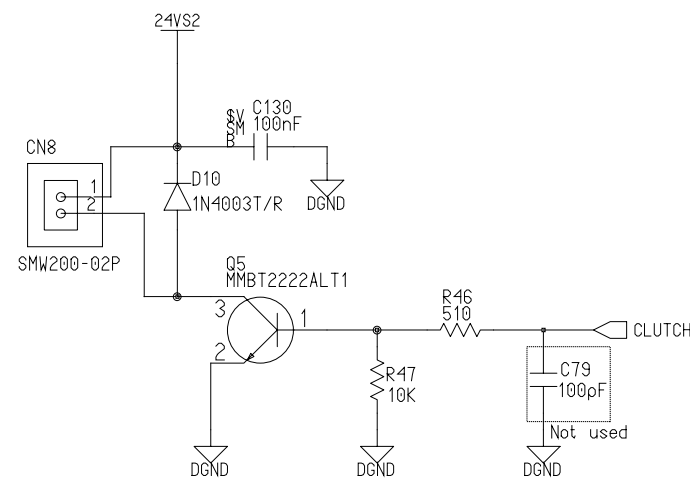

Main Board(4/4)

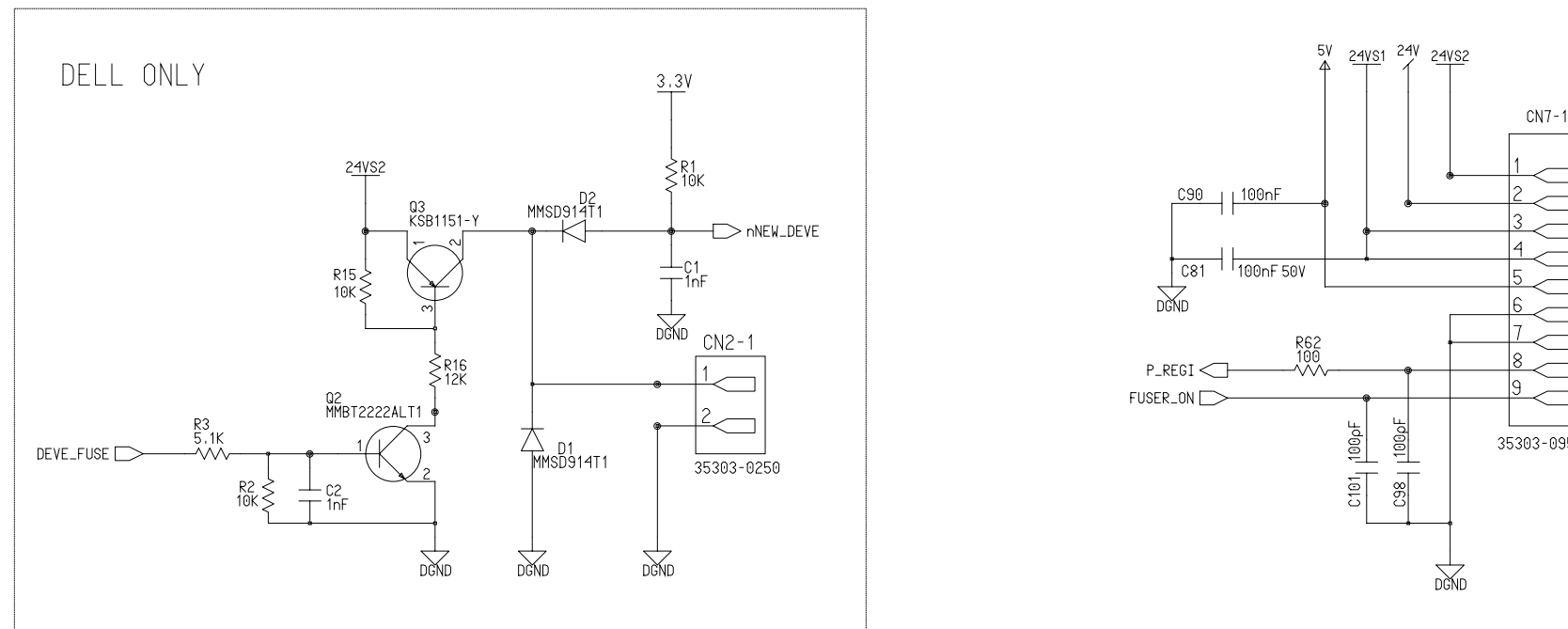
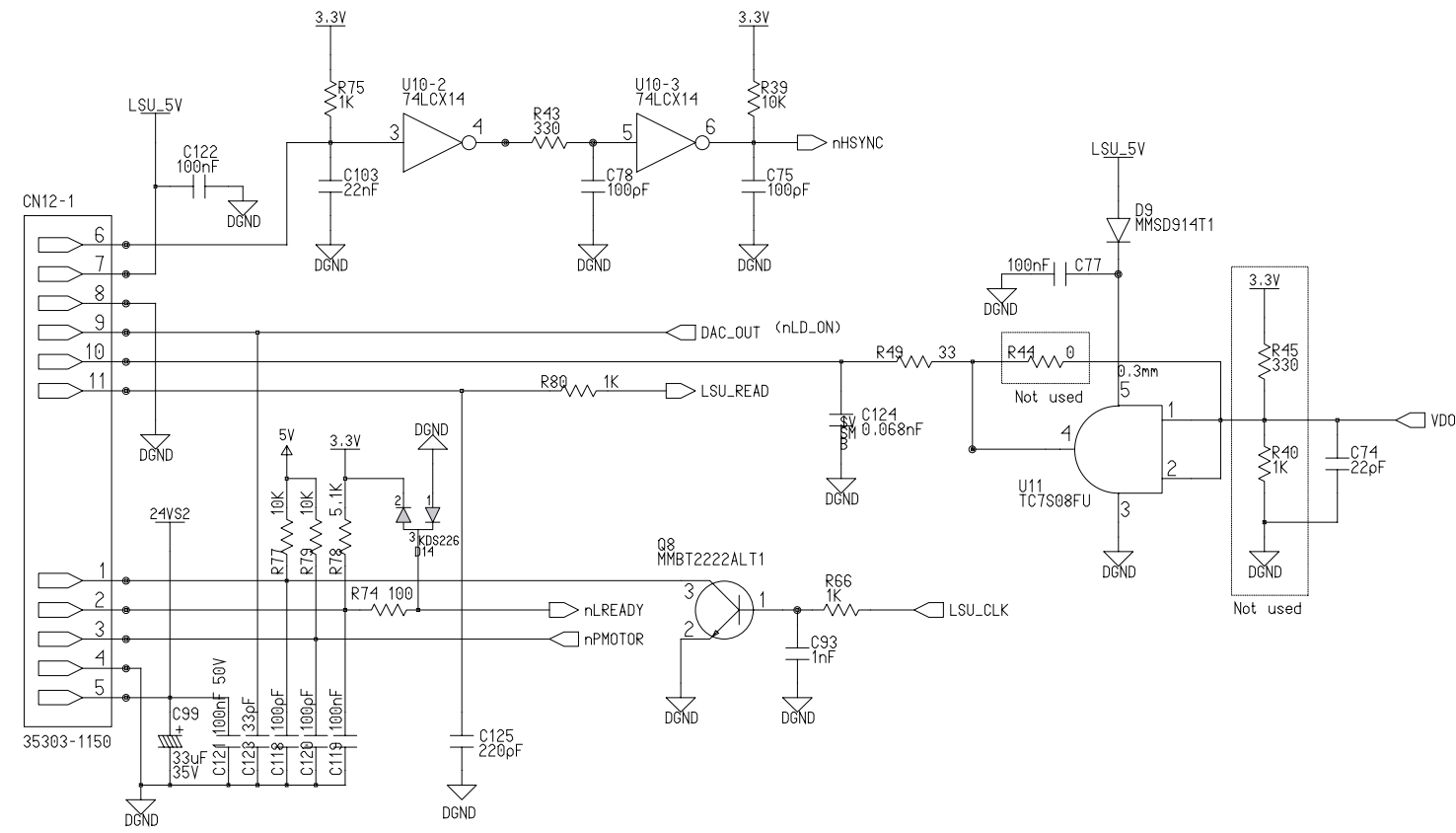

10-2 Connector Circuit Diagram

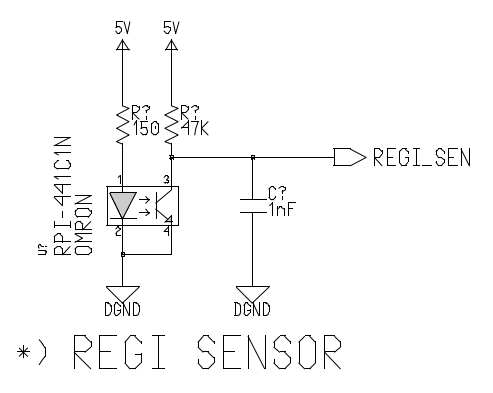
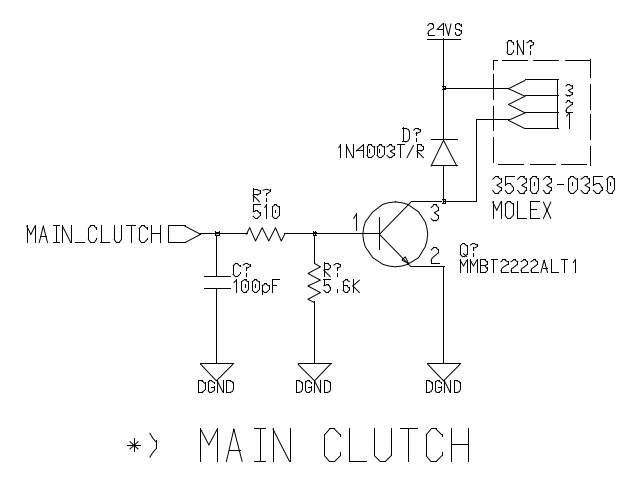
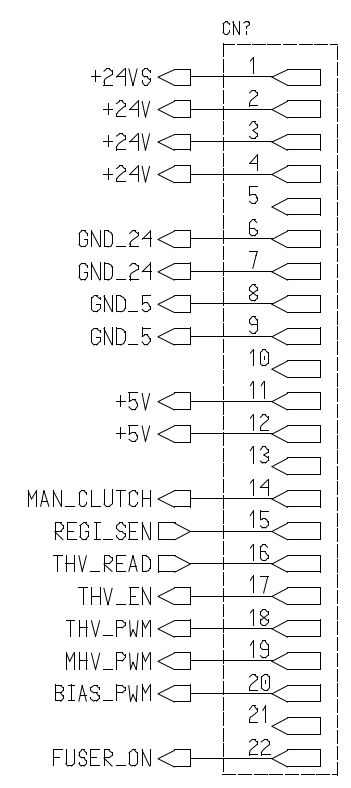
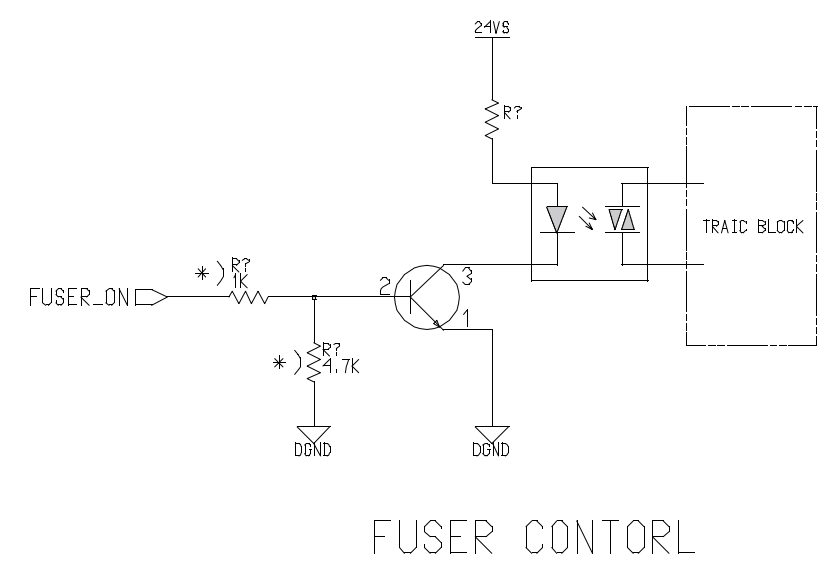
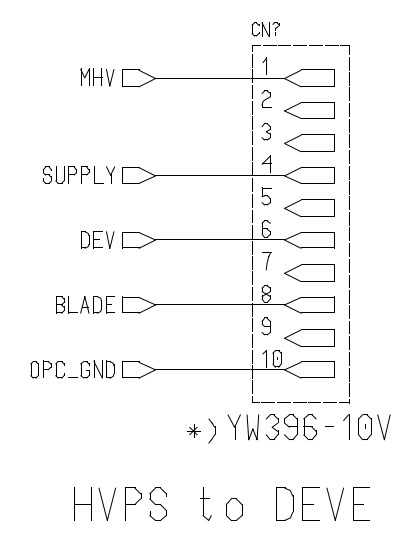

00-6232-022-807-800
 *) SMPS/HVPS TO MAIN

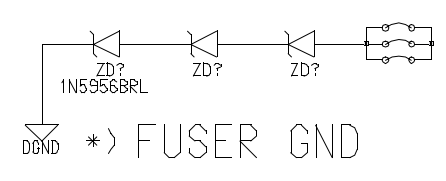
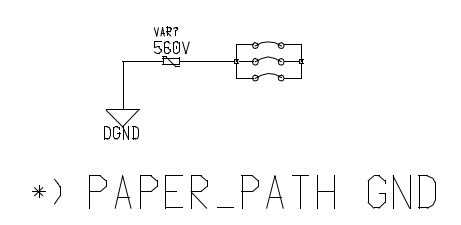

10-4 HVPS Circuit Diagram(1/3)

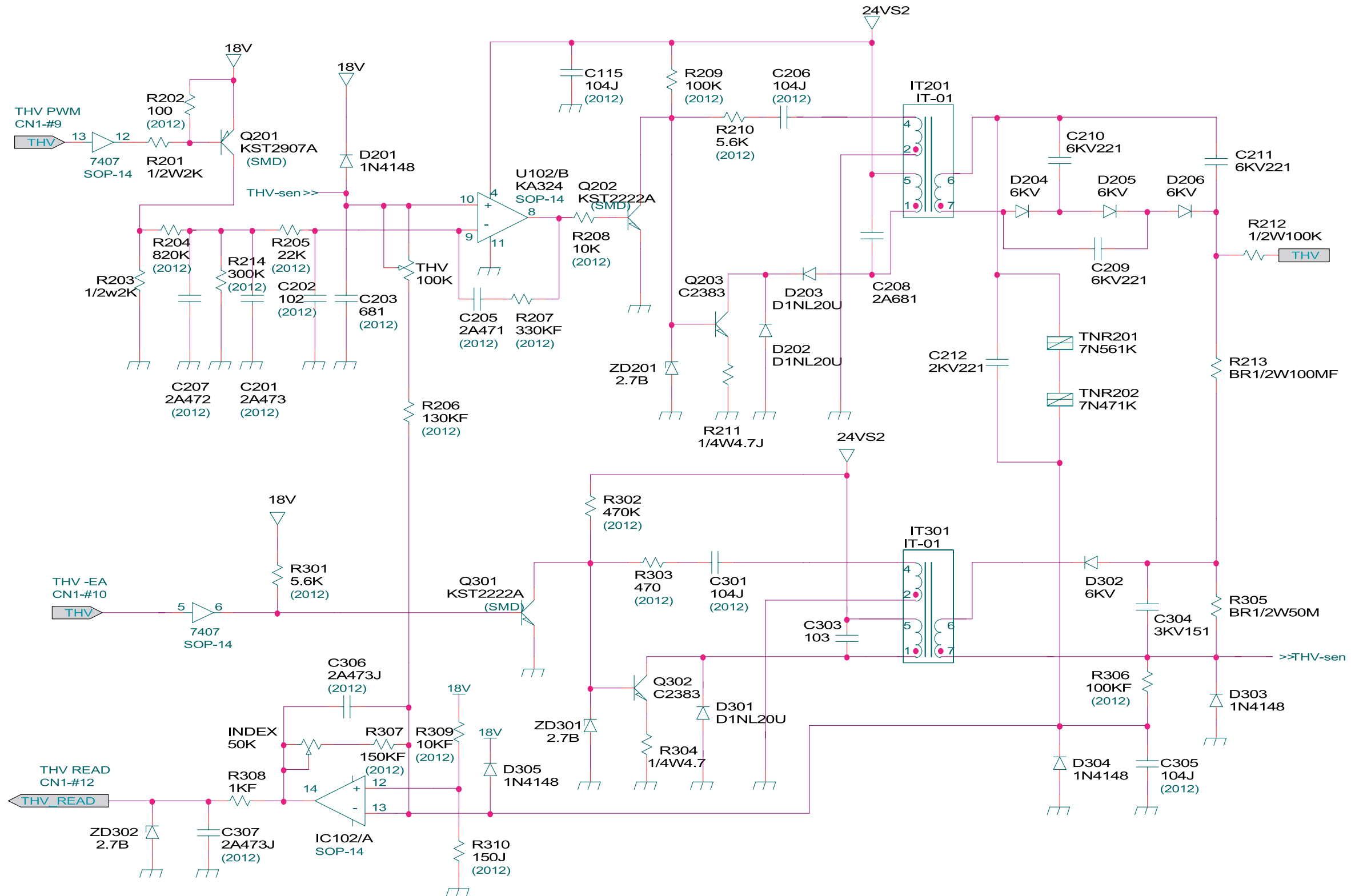

HVPS Circuit Diagram(2/3)

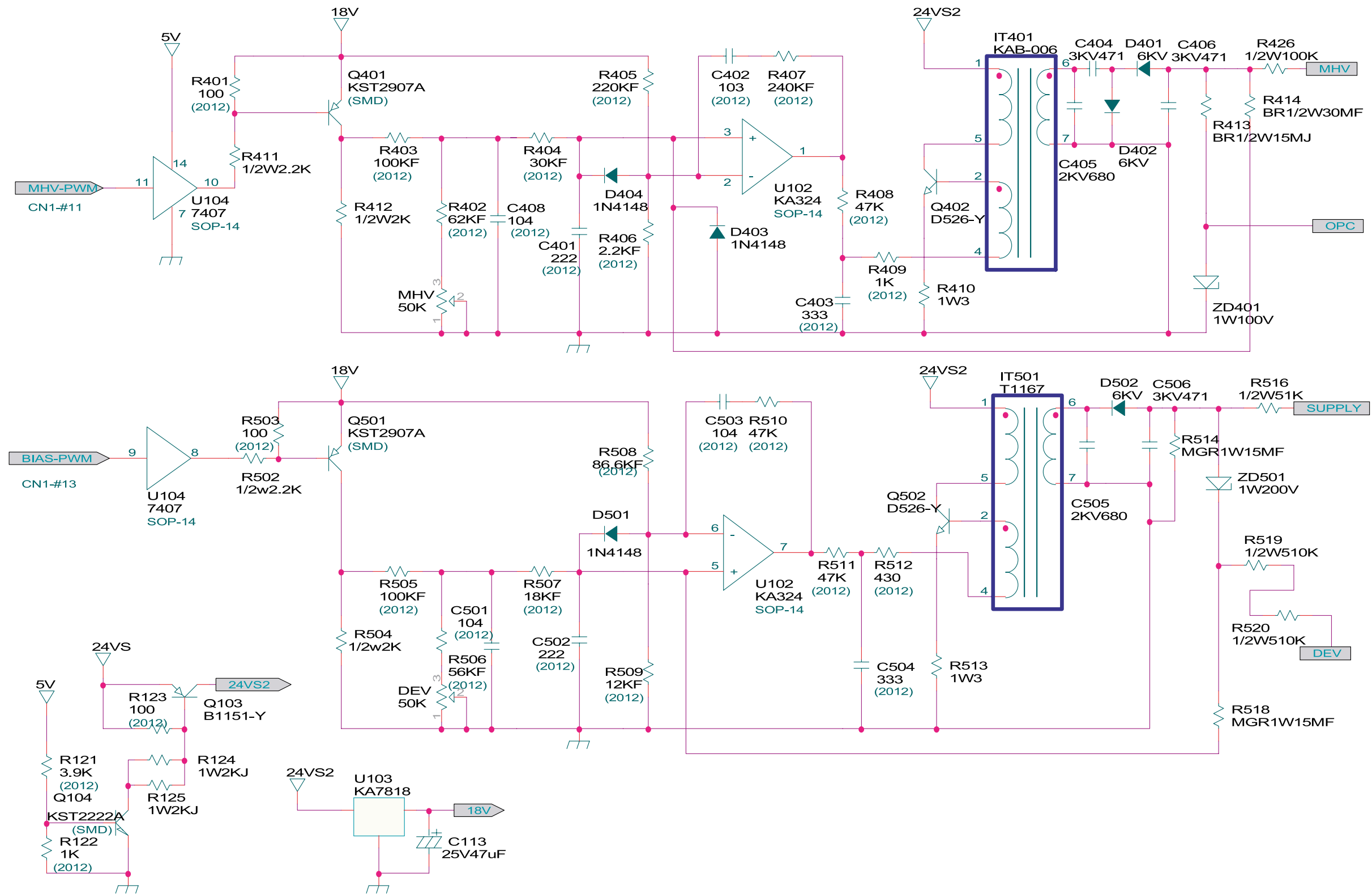

10-4 HVPS Circuit Diagram(3/3)

