

DEVICE	IDSEL	INT#	REQ#	GNT#
PCI1	17	C/D/E/F	PREQ-0	PGNT-0
PCI2	18	D/E/F/G	PREQ-1	PGNT-1
PCI3	19	F/E/H/G	PREQ-2	PGNT-2
LAN	21	E	PREQ-4	PGNT-4

**INTEL
P4 Processor
PSC, Tejas -
LGA 775 pin**

ICS954119
Host Bus: 133/200MHz
DMI, PCIe16, SATA: 100MHz
VGA: 96MHz
USB, SIO: 48MHz
PCI: 33MHz
Timer, Audio: 14.318MHz

BW : 4.1GB/s @ FSB : 533MHz & Freq : 133MHz
BW : 6.4GB/s @ FSB : 800MHz & Freq : 200MHz

SIZE : Min 128MB (ONE 256Mb X 16 Single-Sided DEVICES)
SIZE : Max 4GB (Four 512Mb X 8 Double-Sided DEVICES)
BW : 8.5GB/s @ DDR2 :400/533MHz
BW : 6.4GB/s @ DDR : 333/400MHz

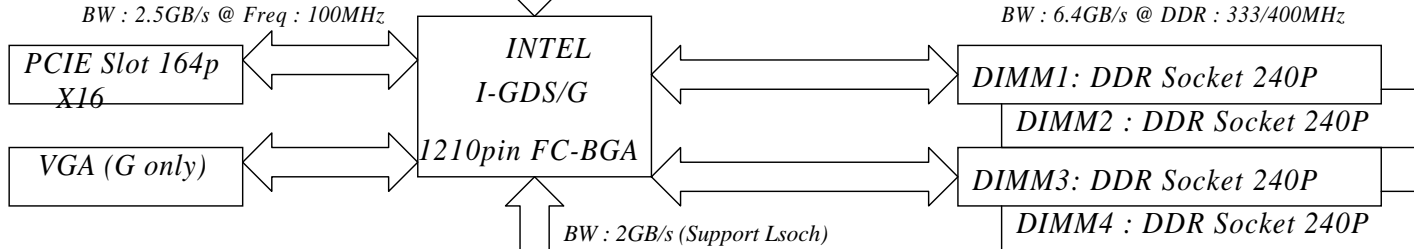

Analog Display
RAMDAC: 400MHz
Resolutions Up To 2048x1536@75Hz

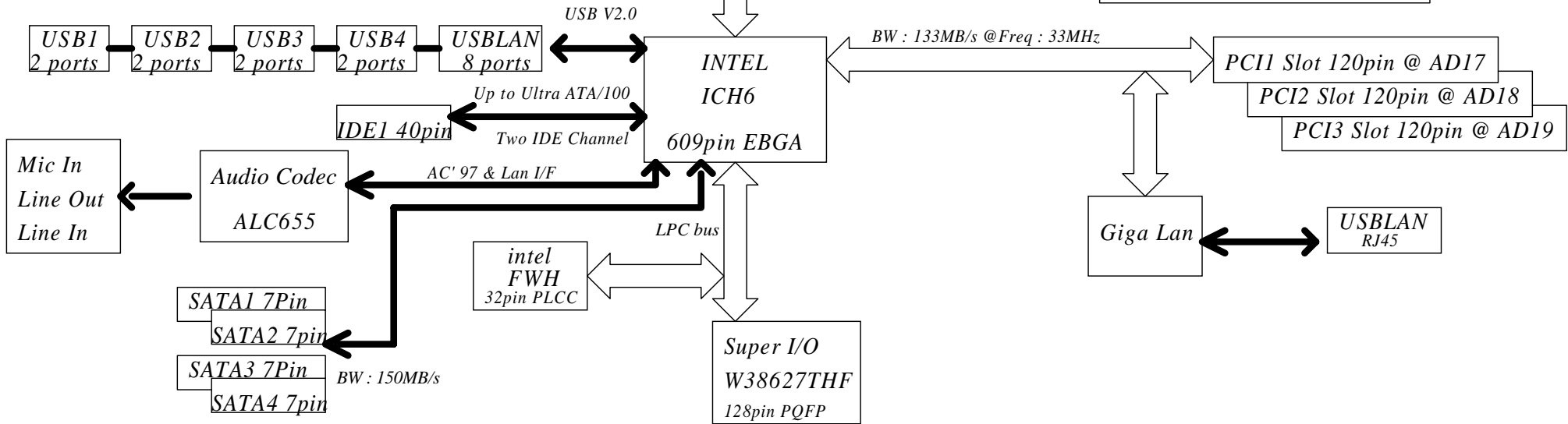

PCB : 244 x 244 mm ; 4 layers

Elitegroup Computer Systems

Title: **System Block Diagram**

Size: Document Number **915GV-M7** Rev **1.0**

Date: Friday, February 04, 2005 Sheet 2 of 34

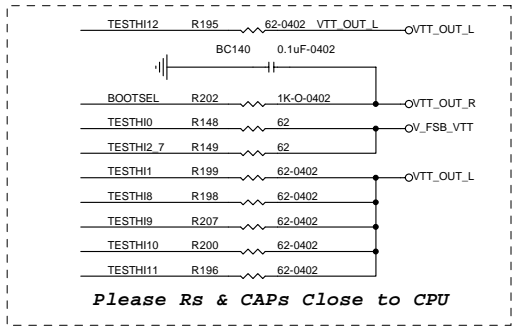
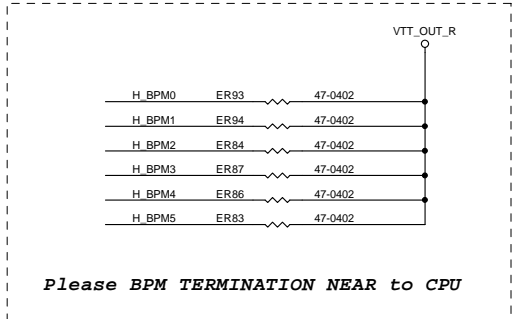
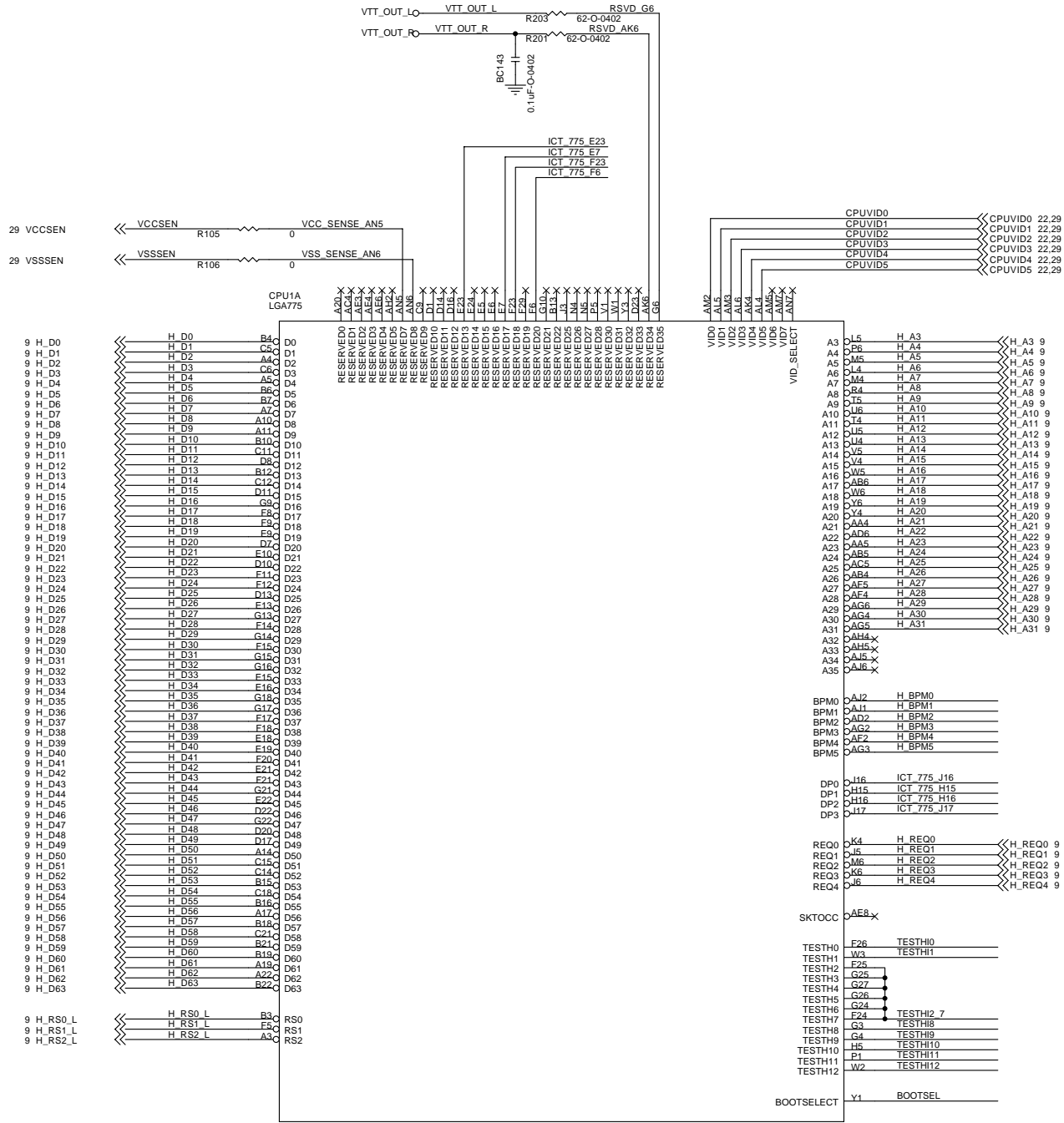

Elitegroup Computer Systems

Title: **P4 LGA775P Part A**

Size: Custom Document Number **915GV-M7** Rev: 1.0

Date: Friday, February 04, 2005 Sheet 3 of 34

Place components as close as possible to Processor socket
trace width to cap must be no smaller than 12 Mils

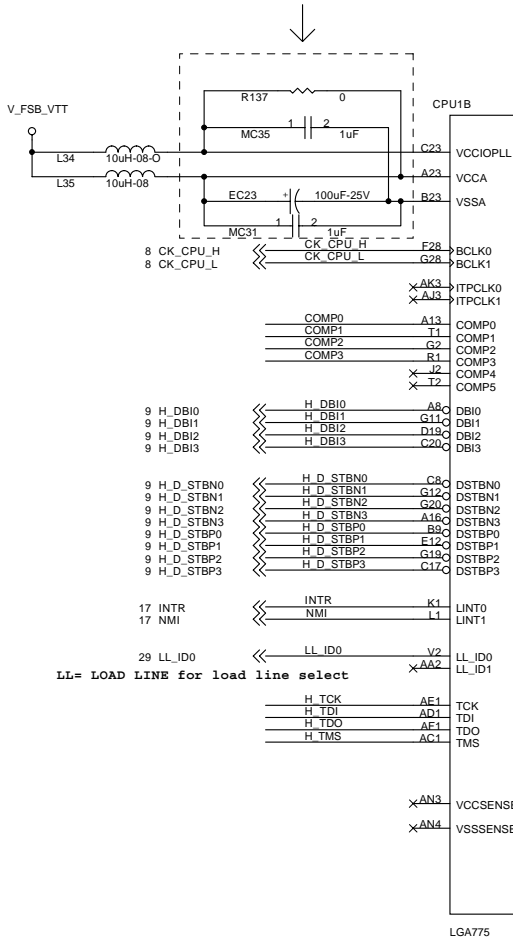

Close CPU H1 pin

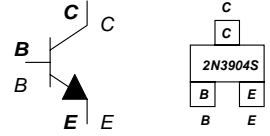
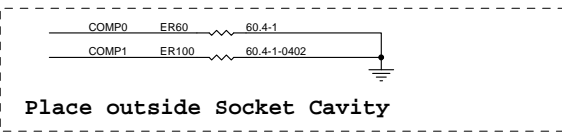
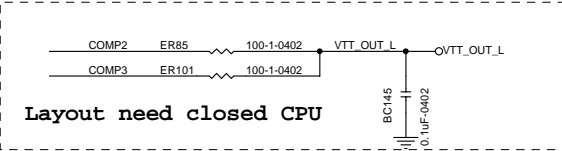
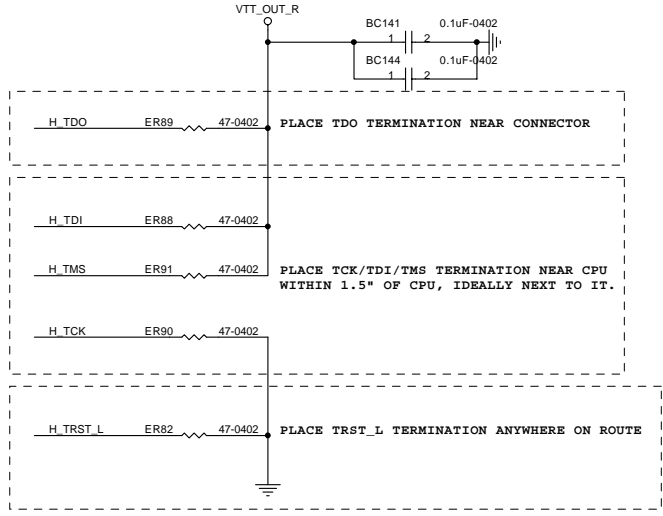
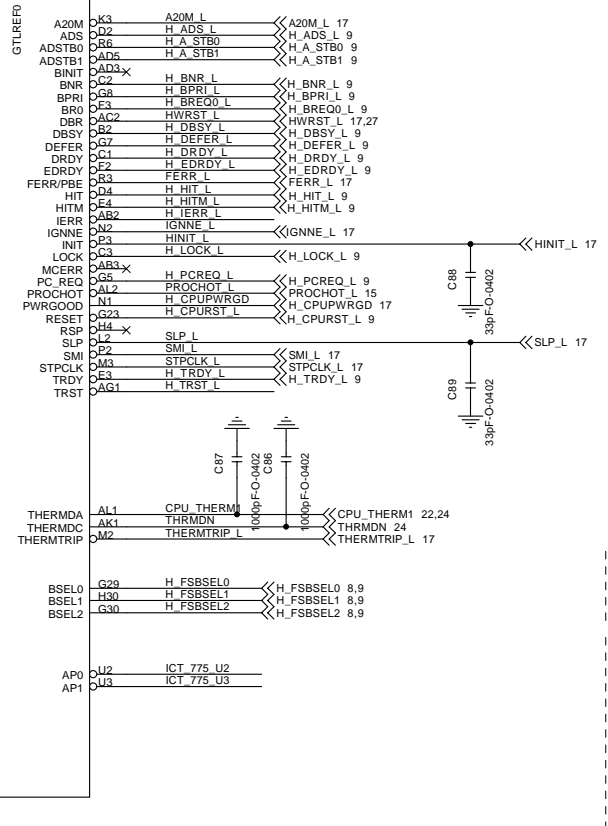
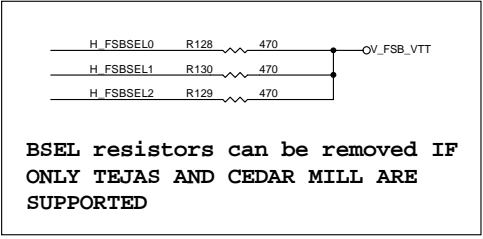
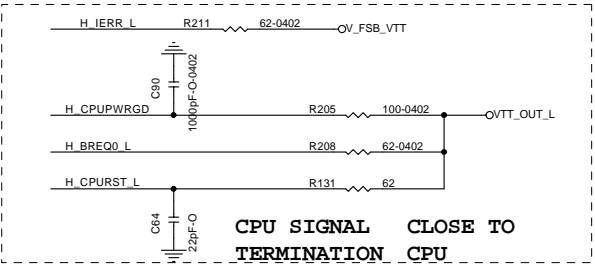
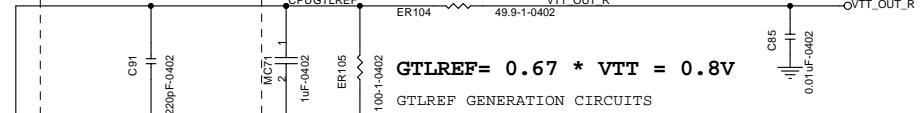

litegroup Computer Systems

Title: **P4 LGA775P Part B**

Size: Custom Document Number: **915GV-M7** Rev: 1.0

Date: Friday, February 04, 2005 Sheet 4 of 34



CPU1C
LGA775

 Elitegroup Computer Systems		
Title P4 LGA775P Part C		
Size Custom	Document Number 915GV-M7	Rev 1.0
Date:	Friday, February 04, 2005	Sheet 5 of 34

CPU1D
LGA775

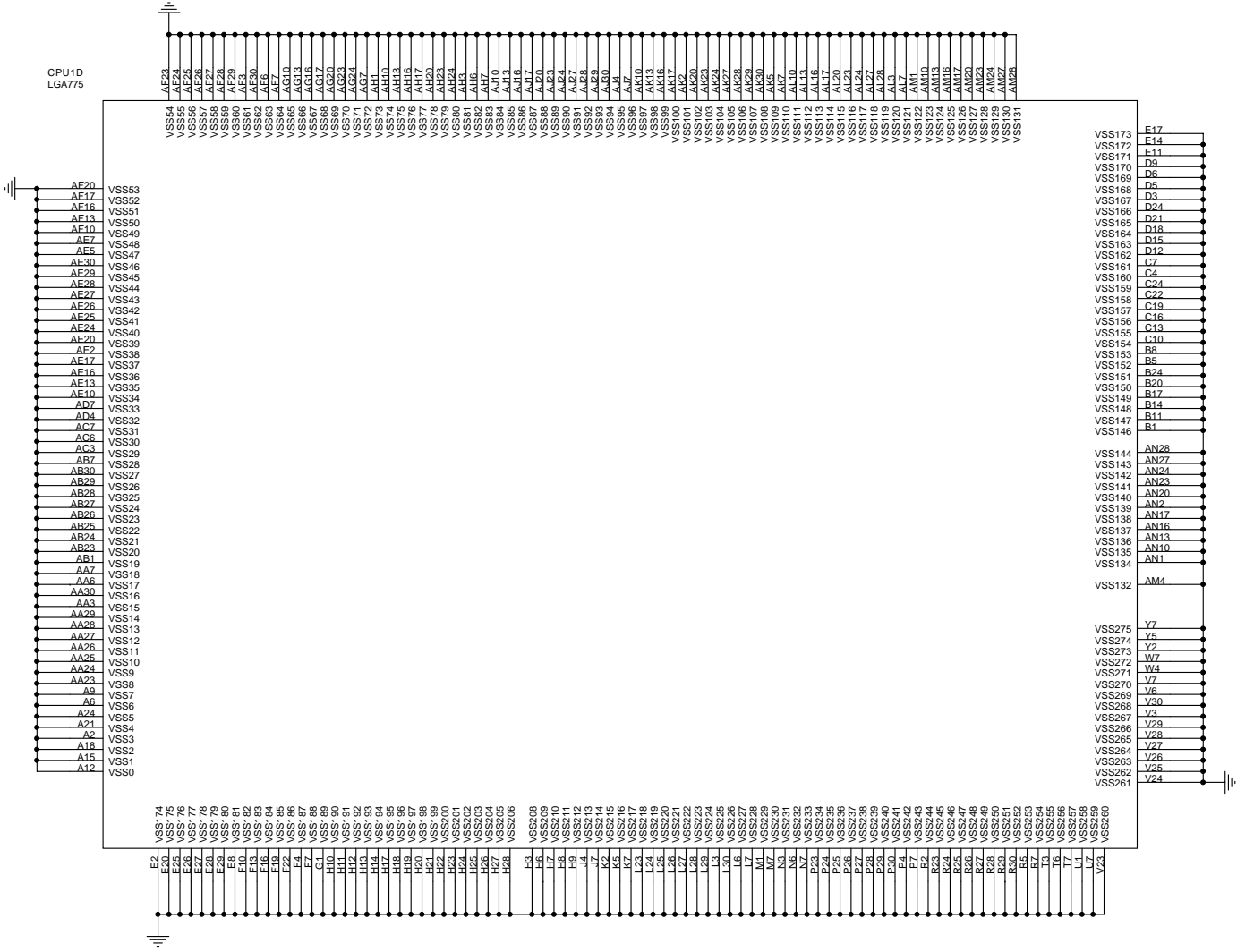

Title P4 LGA775P Part D		
Size Custom	Document Number 915GV-M7	Rev 1.0
Date: Friday, February 04, 2005	Sheet 6	of 34

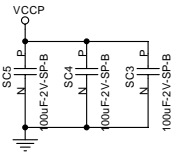
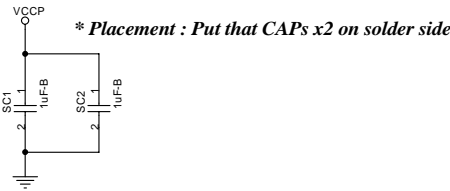
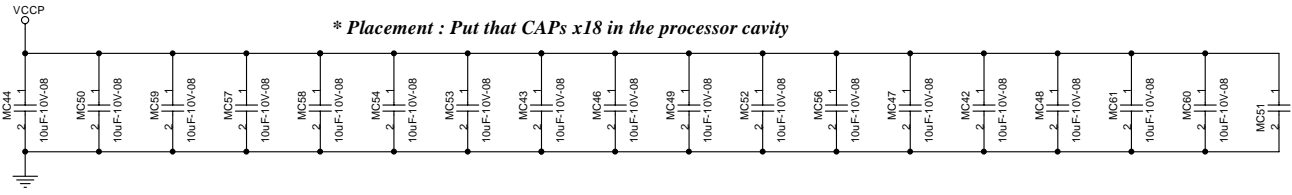

VTT_SEL=0 for the Tejas processor

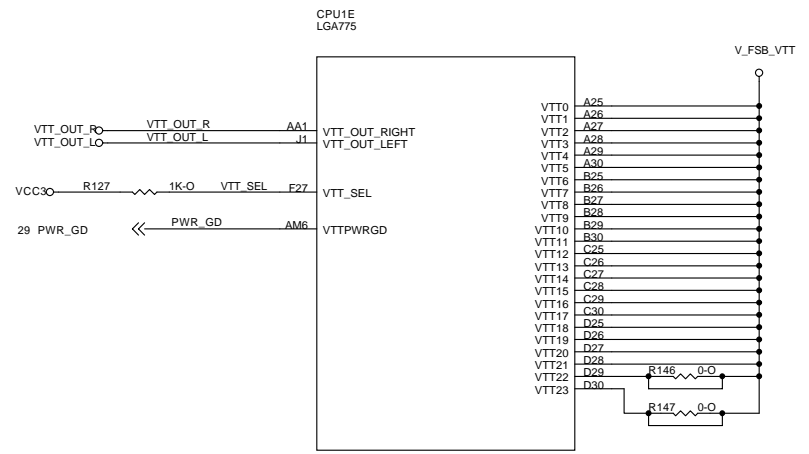

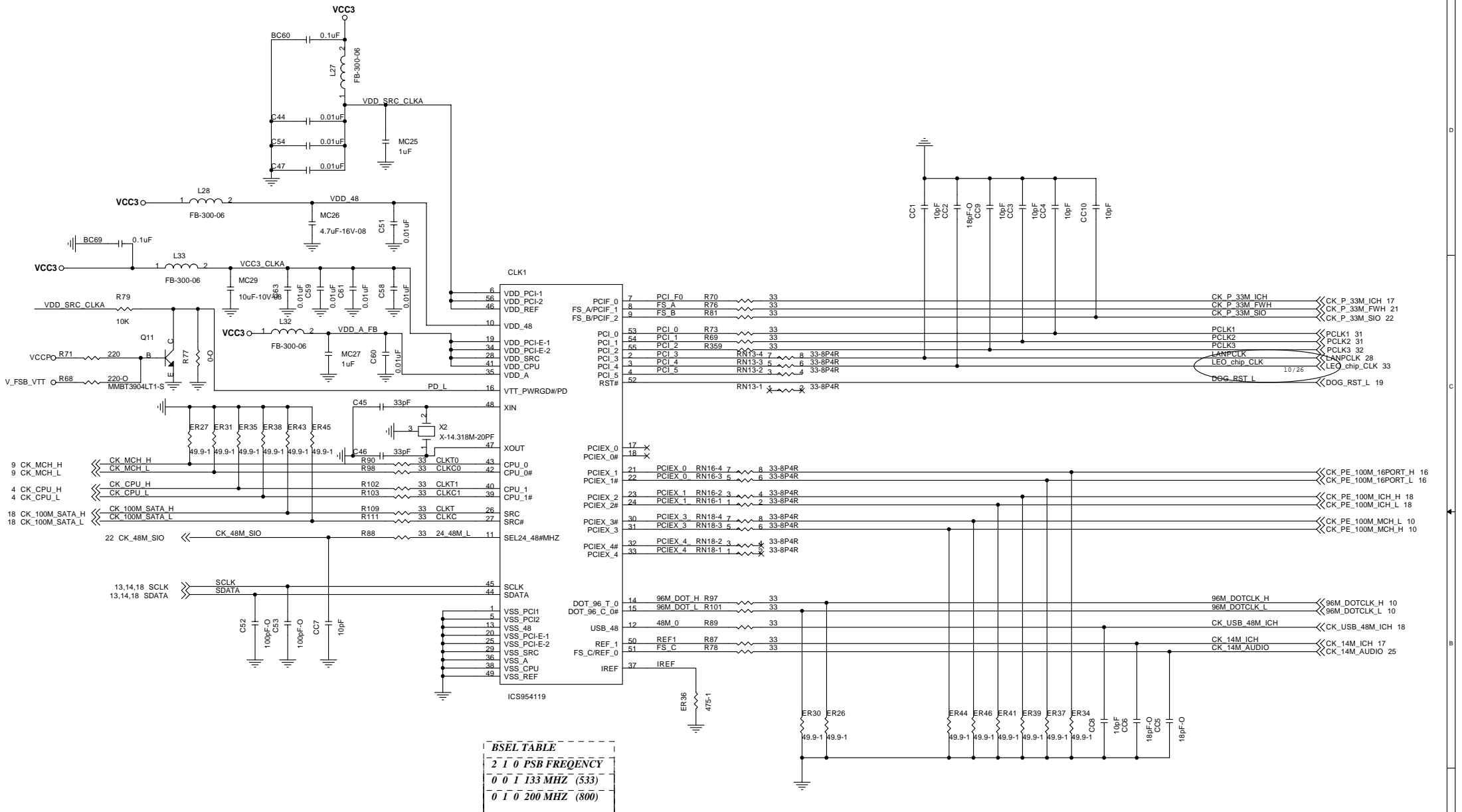

BSEL TABLE

2 1 0 PSB FREQUENCY

0 0 1 133 MHZ (533)

0 1 0 200 MHZ (800)

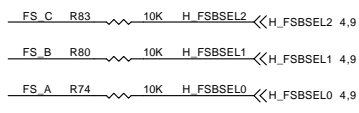

Elitegroup Computer Systems

Title: **Clock Generator(CK410)**

Size: Custom Document Number: **915GV-M7** Rev: 1.0

Date: Friday, February 04, 2005 Sheet 8 of 34

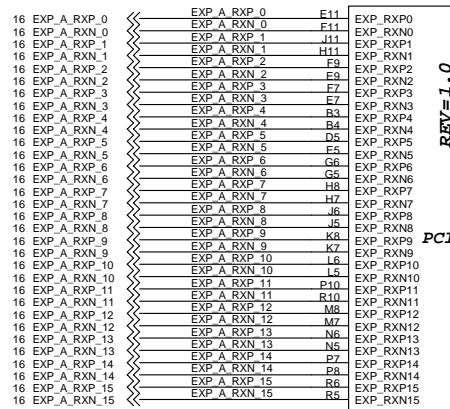

REV=1.0

PCI-B

DMI

VGA

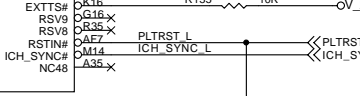
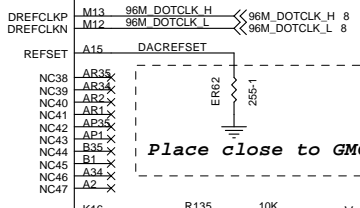
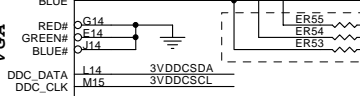
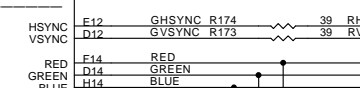
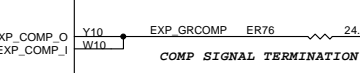
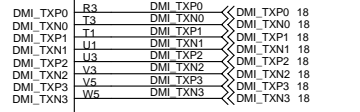
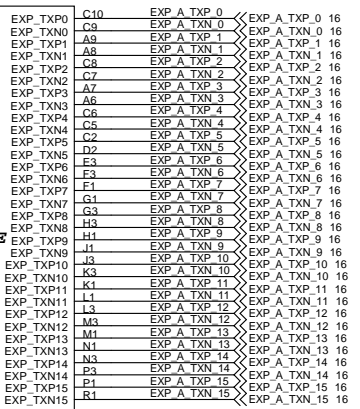

Grantsdale DDR2 MCH_0

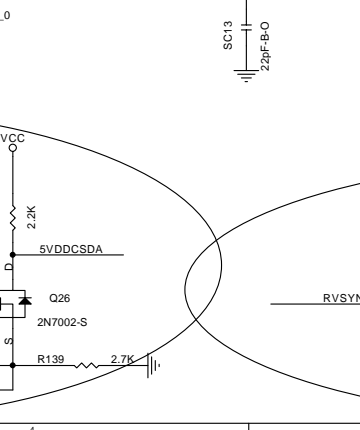
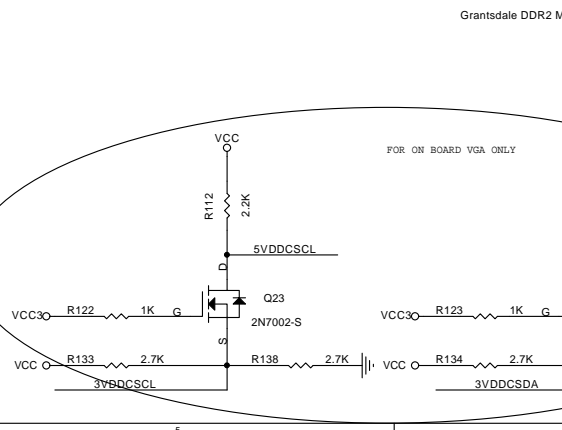
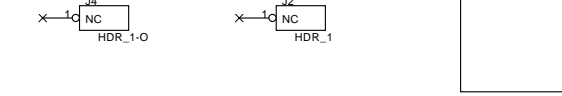
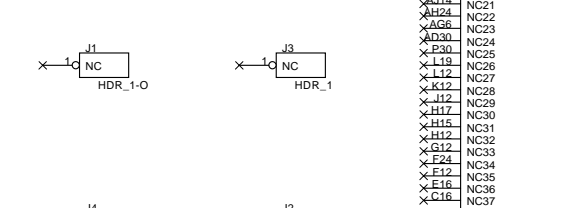
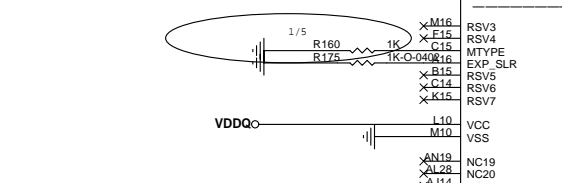
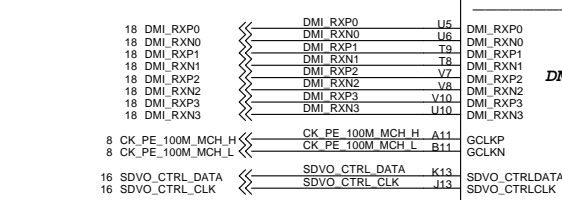
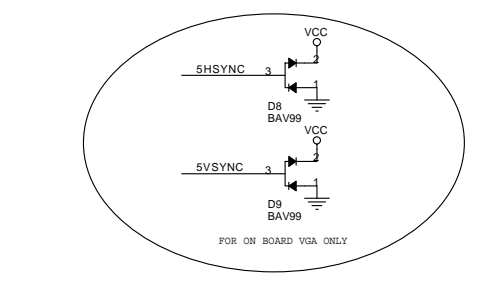
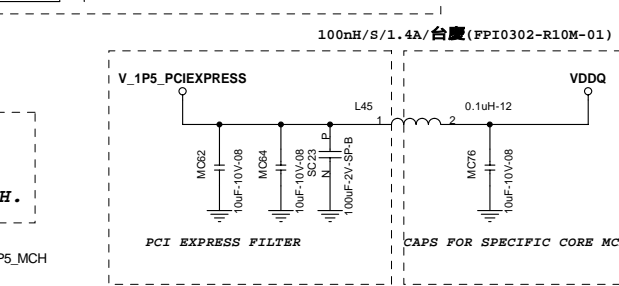
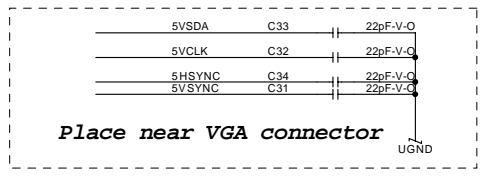
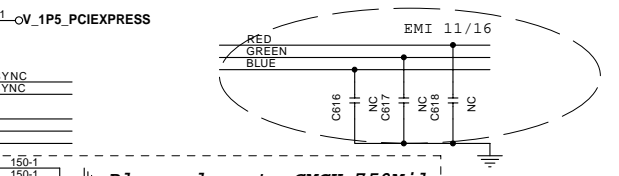
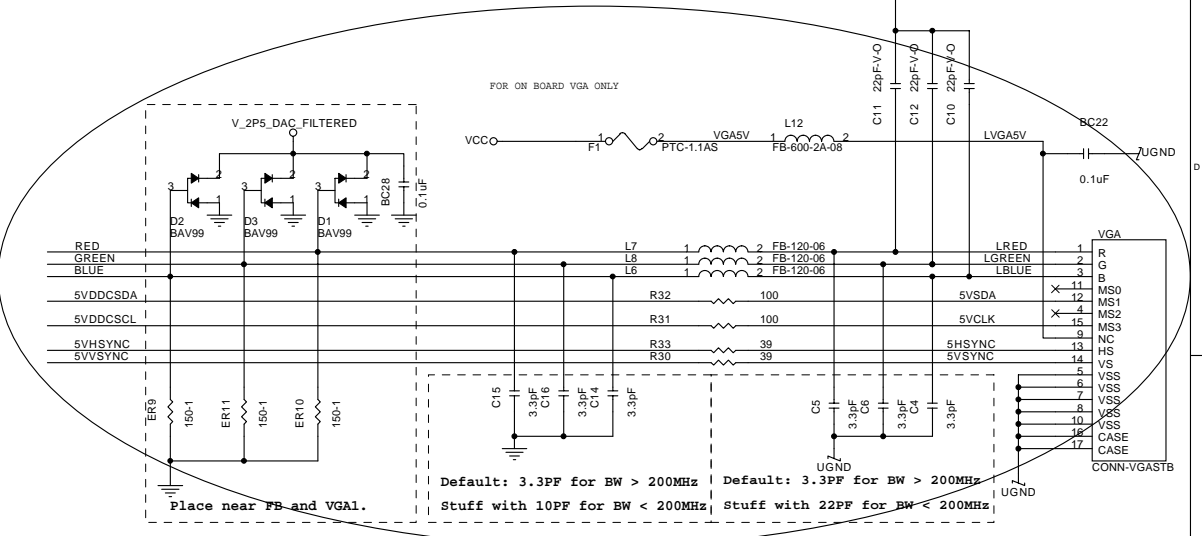

Elitegroup Computer Systems

Title I-GSD(MCH)Part D

Size Document Number 915GV-M7 Rev 1.0

Date: Friday, February 04, 2005 Sheet 10 of 34

GMCHG

AL21	RSV21
AK21	RSV22
AL22	RSV23
AL20	RSV24
AK18	RSV26
AJ24	RSV27
AJ23	RSV28
AJ18	RSV29
AJ20	RSV30

RSV

- A3 VSS
- A5 VSS
- A10 VSS
- A18 VSS
- A26 VSS
- A30 VSS
- A33 VSS
- B2 VSS
- B5 VSS
- B6 VSS
- B7 VSS
- B8 VSS
- B9 VSS
- B10 VSS
- B12 VSS
- B14 VSS
- B16 VSS
- B18 VSS
- B24 VSS
- B28 VSS
- C1 VSS
- C3 VSS
- C4 VSS
- C11 VSS
- C13 VSS
- C17 VSS
- C18 VSS
- C23 VSS
- C35 VSS
- D3 VSS
- D4 VSS
- D6 VSS
- D7 VSS
- D8 VSS
- D9 VSS
- D10 VSS
- D11 VSS
- D15 VSS
- D16 VSS
- D18 VSS
- D23 VSS
- D25 VSS
- D26 VSS
- D28 VSS
- D30 VSS
- D31 VSS
- D32 VSS
- E1 VSS
- E2 VSS
- E4 VSS
- E6 VSS
- E8 VSS
- E10 VSS
- E17 VSS
- E18 VSS
- E23 VSS
- E26 VSS
- E29 VSS
- F2 VSS
- F4 VSS
- F5 VSS
- F6 VSS
- F8 VSS
- F10 VSS
- F16 VSS
- F18 VSS
- F23 VSS
- F26 VSS
- F29 VSS
- F30 VSS
- F32 VSS
- F35 VSS

- G2 VSS
- G4 VSS
- G5 VSS
- G6 VSS
- G9 VSS
- G10 VSS
- G13 VSS
- G15 VSS
- G17 VSS
- G20 VSS
- G23 VSS
- G26 VSS
- G27 VSS
- H2 VSS
- H4 VSS
- H5 VSS
- H6 VSS
- H8 VSS
- H9 VSS
- H10 VSS
- H13 VSS
- H24 VSS
- H25 VSS
- H27 VSS
- H29 VSS
- H30 VSS
- H32 VSS
- H34 VSS
- I2 VSS
- I4 VSS
- I6 VSS
- I8 VSS
- I9 VSS
- I11 VSS
- I13 VSS
- I15 VSS
- I17 VSS
- I18 VSS
- I20 VSS
- I24 VSS
- I27 VSS
- I30 VSS
- I32 VSS
- I34 VSS
- I35 VSS
- J2 VSS
- J4 VSS
- J6 VSS
- J8 VSS
- J9 VSS
- J10 VSS
- J16 VSS
- J17 VSS
- J18 VSS
- J21 VSS
- J22 VSS
- J23 VSS
- J24 VSS
- J25 VSS
- J26 VSS
- J27 VSS
- J28 VSS
- J29 VSS
- J30 VSS
- J31 VSS
- J32 VSS
- K2 VSS
- K4 VSS
- K6 VSS
- K9 VSS
- K10 VSS
- K14 VSS
- K20 VSS
- K24 VSS
- K28 VSS
- K31 VSS
- K32 VSS
- K42 VSS
- L2 VSS
- L4 VSS
- L7 VSS
- L8 VSS
- L9 VSS
- L11 VSS
- L13 VSS
- L15 VSS
- L17 VSS
- L18 VSS
- L20 VSS
- L24 VSS
- L27 VSS
- L30 VSS
- M2 VSS
- M4 VSS
- M6 VSS
- M8 VSS
- M9 VSS
- M17 VSS
- M20 VSS
- M25 VSS
- M27 VSS
- M29 VSS
- M32 VSS
- N2 VSS
- N4 VSS
- N7 VSS
- N8 VSS
- N10 VSS
- N28 VSS
- N30 VSS
- P2 VSS
- P4 VSS
- P5 VSS
- P6 VSS
- P7 VSS
- P20 VSS
- P21 VSS
- P30 VSS
- P35 VSS
- R2 VSS
- R4 VSS
- R9 VSS
- R8 VSS
- R9 VSS
- R26 VSS
- R27 VSS

Grantsdale DDR2 MCH_0

- AR30 VSS
- AR32 VSS
- AR17 VSS
- AR13 VSS
- AR8 VSS
- APR VSS
- APR VSS
- AM1 VSS
- AM2 VSS
- AM6 VSS
- AM7 VSS
- AM8 VSS
- AM8 VSS
- AL12 VSS
- AL19 VSS
- AL16 VSS
- AL10 VSS
- AK30 VSS
- AK28 VSS
- AK25 VSS
- AK25 VSS
- AK20 VSS
- AK14 VSS
- AK11 VSS
- AK8 VSS
- AK6 VSS
- AK4 VSS
- AK1 VSS
- AR5 VSS
- AR0 VSS
- AR27 VSS
- AJ22 VSS
- AJ18 VSS
- AJ15 VSS
- AJ13 VSS
- AJ0 VSS
- AJ4 VSS
- AH34 VSS
- AH32 VSS
- AH26 VSS
- AH23 VSS
- AH20 VSS
- AH14 VSS
- AH11 VSS
- AH8 VSS
- AH5 VSS
- AH1 VSS
- AG29 VSS
- AG28 VSS
- AG25 VSS
- AG22 VSS
- AG21 VSS
- AG18 VSS
- AG16 VSS
- AG15 VSS
- AG12 VSS
- AG5 VSS
- AE35 VSS
- AE32 VSS
- AE30 VSS
- AE29 VSS
- AE26 VSS
- AE26 VSS
- AE18 VSS
- AE15 VSS
- AE12 VSS
- AE10 VSS
- AE8 VSS
- AE4 VSS
- AE2 VSS

- AE30 VSS
- AE28 VSS
- AE23 VSS
- AE23 VSS
- AE21 VSS
- AE20 VSS
- AE18 VSS
- AE17 VSS
- AE15 VSS
- AE14 VSS
- AE12 VSS
- AE9 VSS
- AE6 VSS
- AE4 VSS
- AD34 VSS
- AD27 VSS
- AD26 VSS
- AD22 VSS
- AD19 VSS
- AD16 VSS
- AD13 VSS
- AD11 VSS
- AC32 VSS
- AC31 VSS
- AC29 VSS
- AC27 VSS
- AB35 VSS
- AB32 VSS
- AB30 VSS
- AB28 VSS
- AA27 VSS
- AA26 VSS
- AA10 VSS
- AA9 VSS
- AA8 VSS
- AA7 VSS
- AA6 VSS
- AA5 VSS
- AA4 VSS
- AA3 VSS
- AA2 VSS
- AA1 VSS
- Y34 VSS
- Y32 VSS
- Y31 VSS
- Y29 VSS
- Y27 VSS
- Y22 VSS
- W32 VSS
- W30 VSS
- W28 VSS
- W19 VSS
- W17 VSS
- V35 VSS
- V27 VSS
- V26 VSS
- V18 VSS
- V9 VSS
- V6 VSS
- V4 VSS
- V2 VSS
- V1 VSS
- U32 VSS
- U31 VSS
- U29 VSS
- U27 VSS
- U19 VSS
- U17 VSS
- U8 VSS
- U8 VSS
- U7 VSS
- U4 VSS
- U2 VSS
- T34 VSS
- T32 VSS
- T30 VSS
- T28 VSS
- T10 VSS
- T7 VSS
- T6 VSS
- T5 VSS
- T4 VSS
- T2 VSS

REV=1.0

GND

 **Elitegroup Computer Systems**

Title: **Schematic Change History**

Size: Custom Document Number: **915GV-M7** Rev: **1.0**

Date: Friday, February 04, 2005 Sheet 12 of 34

DIMM3
DDR2

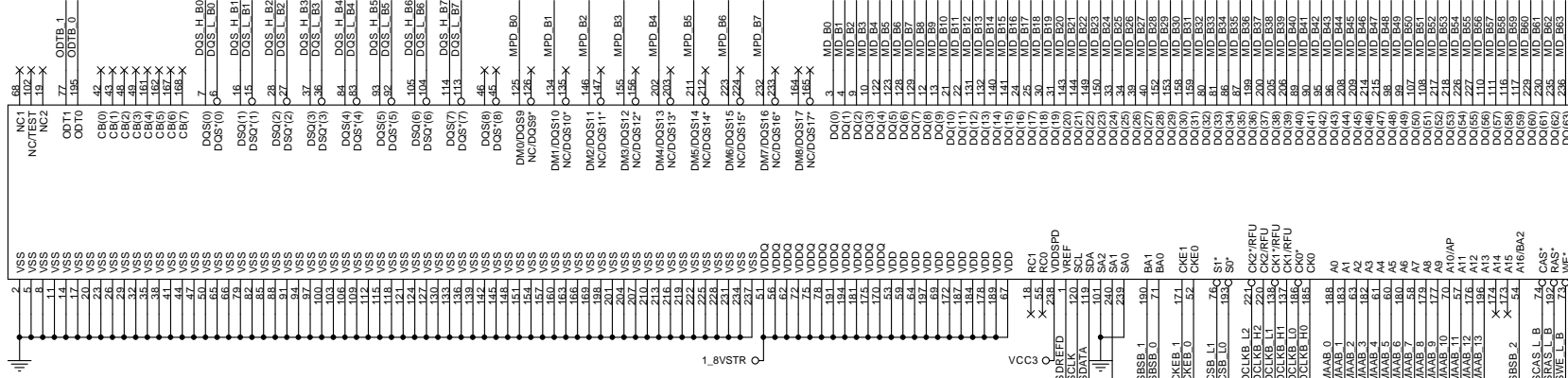

DIMM4
DDR2

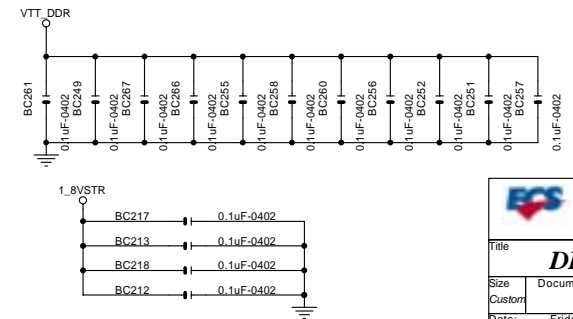
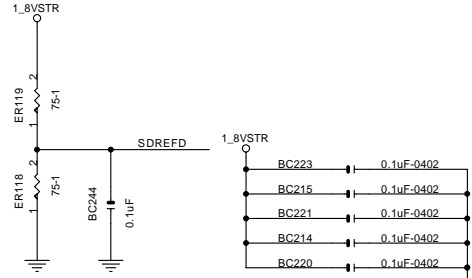
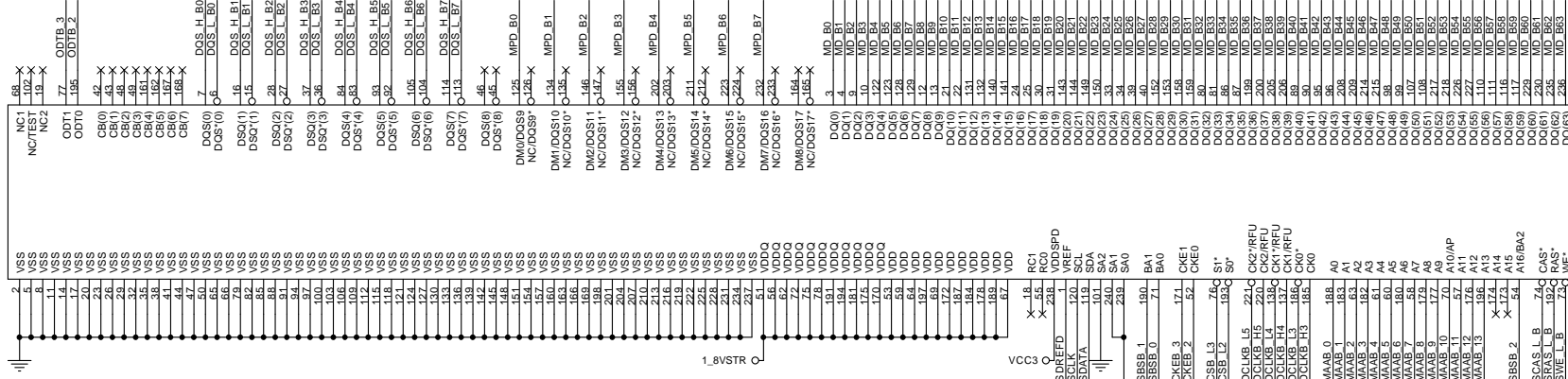

- 11 MD_B[0..63] <<< MD_B[0..63]
- 11 DQS_L_B[0..7] <<< DQS_L_B[0..7]
- 11 DQS_H_B[0..7] <<< DQS_H_B[0..7]
- 11 MPD_B[0..7] <<< MPD_B[0..7]
- 11 MAAB_[0..13] <<< MAAB_[0..13]
- 11 CSB_L[0..3] <<< CSB_L[0..3]
- 11 CKEB_[0..3] <<< CKEB_[0..3]
- 11 DCLKB_L[0..5] <<< DCLKB_L[0..5]
- 11 DCLKB_H[0..5] <<< DCLKB_H[0..5]
- 11 ODTB_[0..3] <<< ODTB_[0..3]
- 11 SBSB_[0..2] <<< SBSB_[0..2]
- 11 SWE_L_B <<< SWE_L_B
- 11 SCAS_L_B <<< SCAS_L_B
- 11 SRAS_L_B <<< SRAS_L_B
- 11 SDATA <<< SDATA
- 11 SCLK <<< SCLK

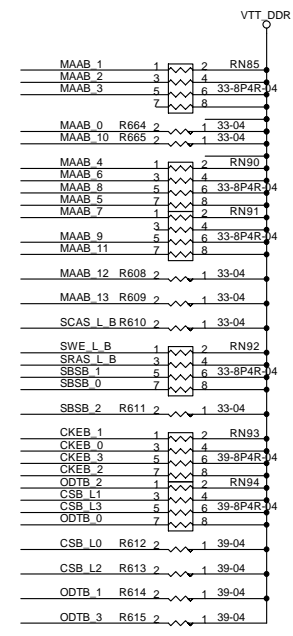

Elitegroup Computer Systems
DIMM 3&4 (DDR2 SDRAMs)
 Size: Document Number 915GV-M7
 Date: Friday, February 04, 2005 Sheet 14 of 34
 Rev 1.0

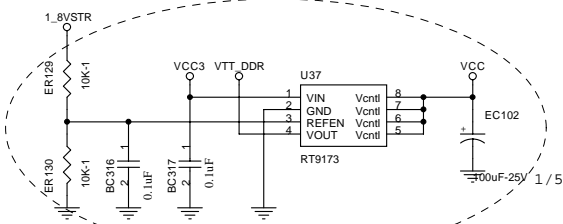

VR THERMAL THROTTLE CIRCUITRY

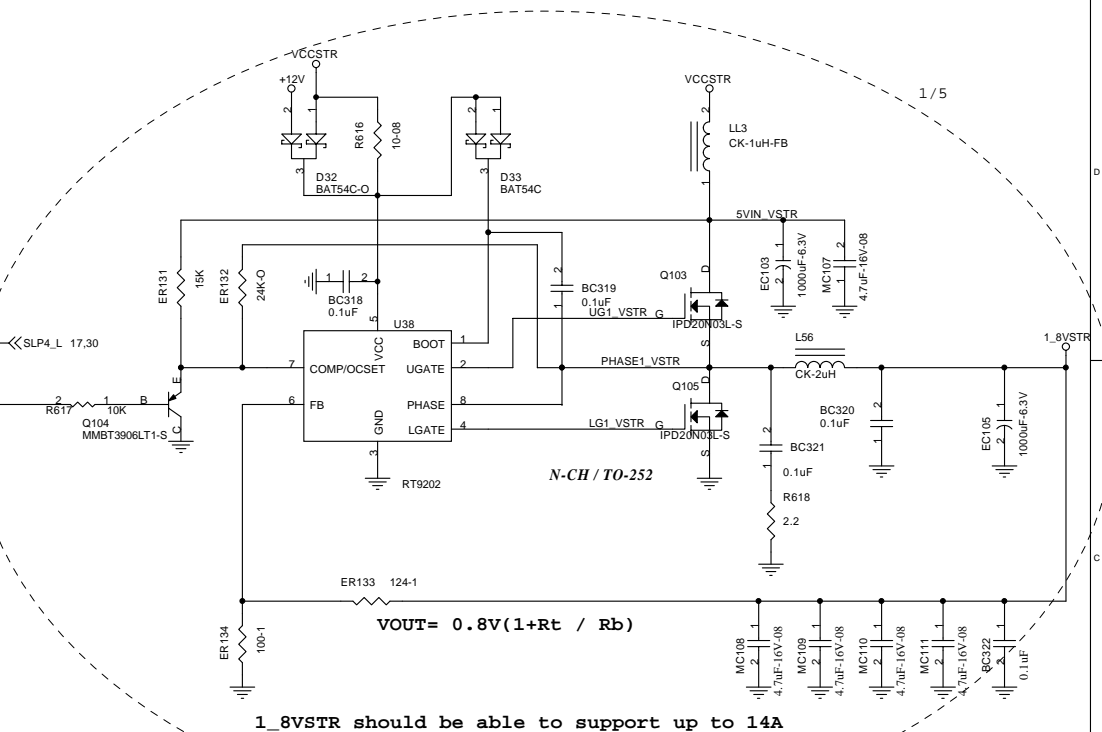
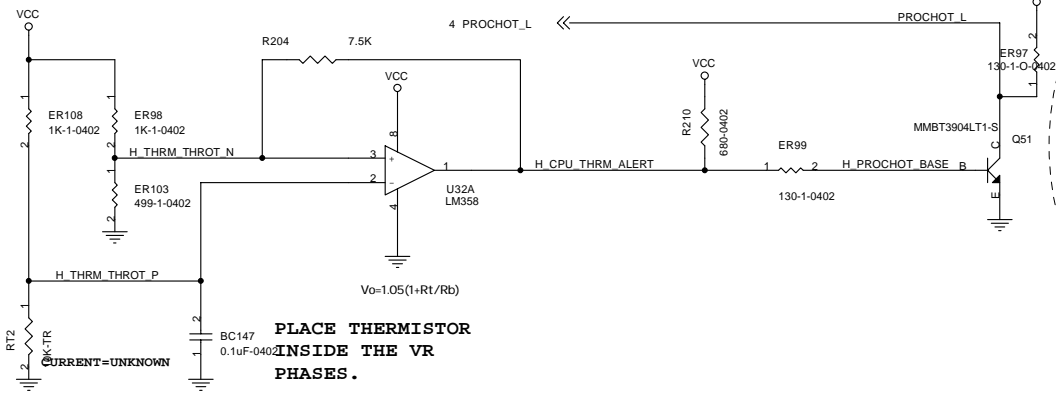

1.8VSTR should be able to support up to 14A

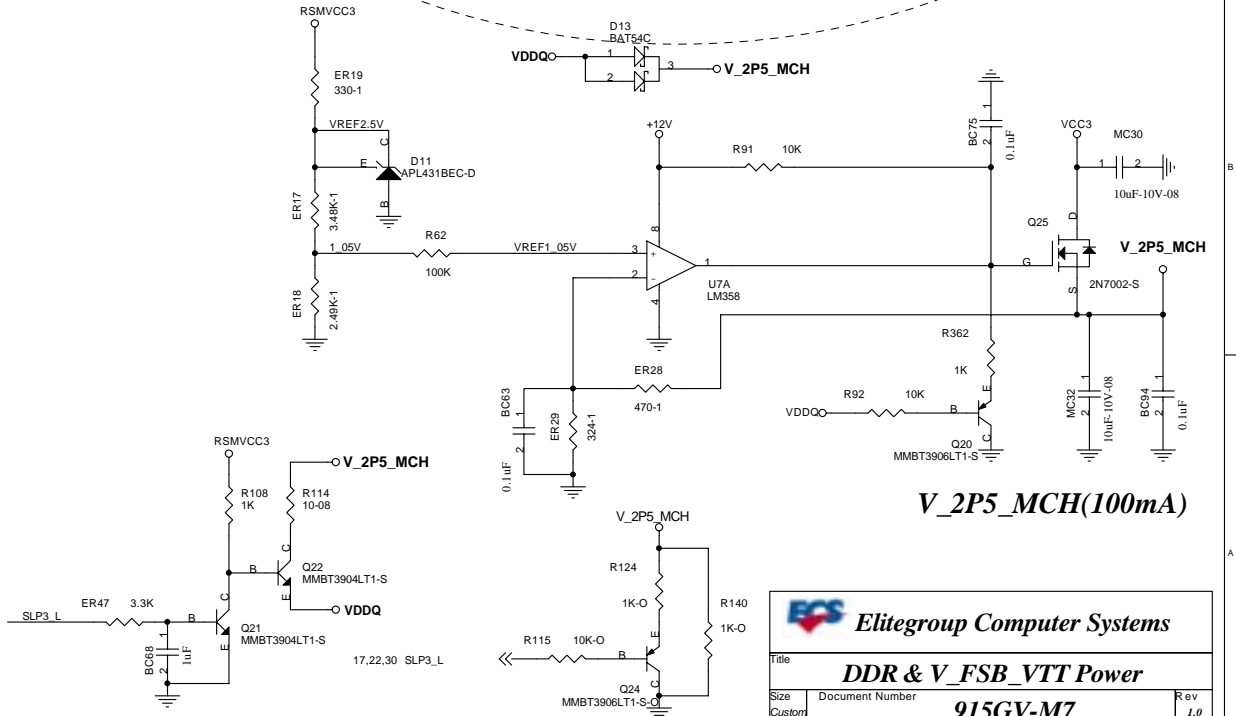
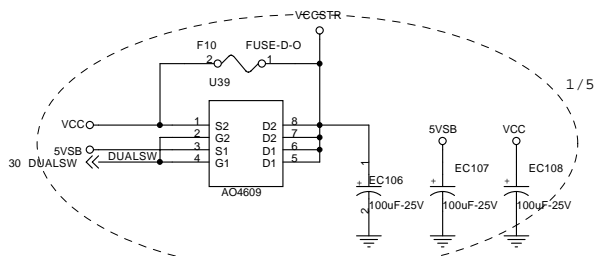
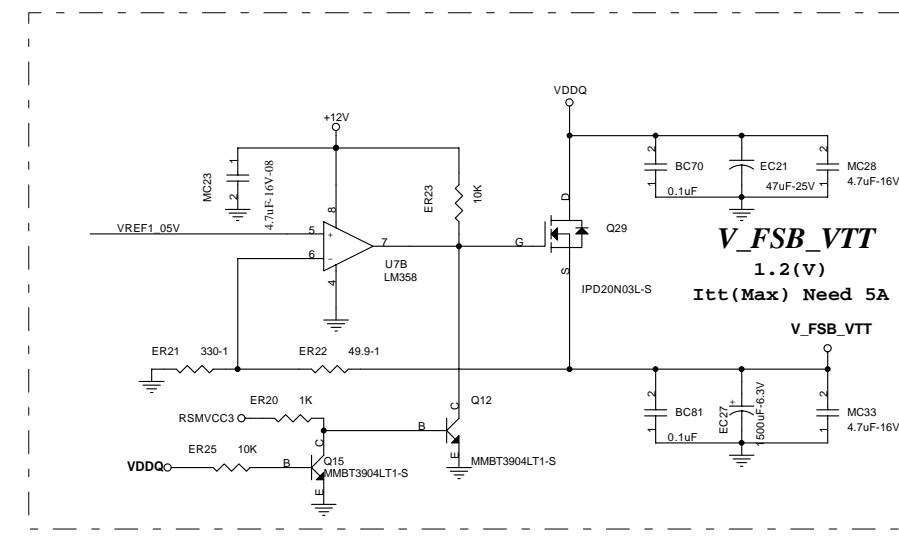



18,31,32 SMBCLK
18,31,32 SMBDATA

17 PCIE_WAKE_L

10 SDVO_CTRL_CLK

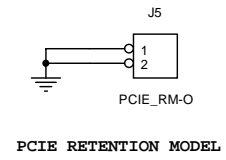
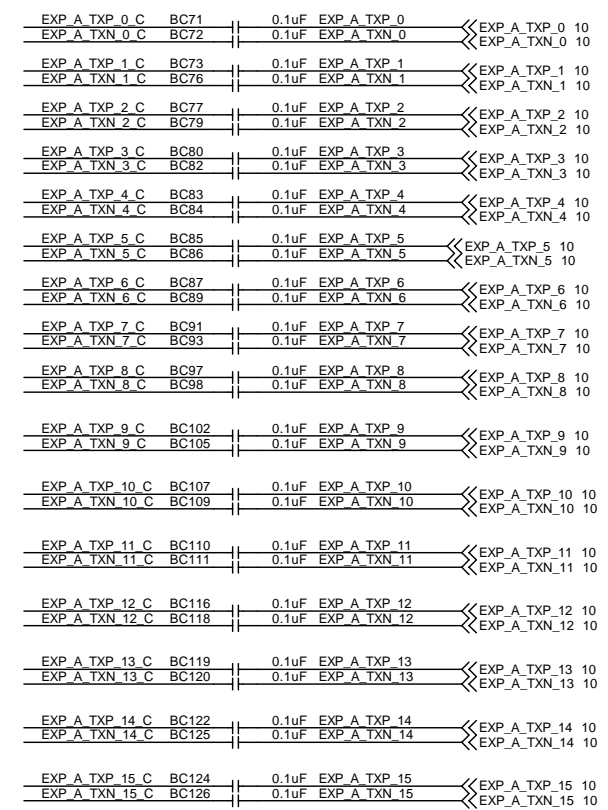
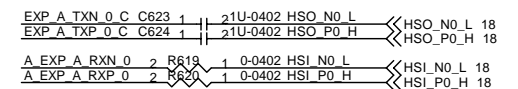
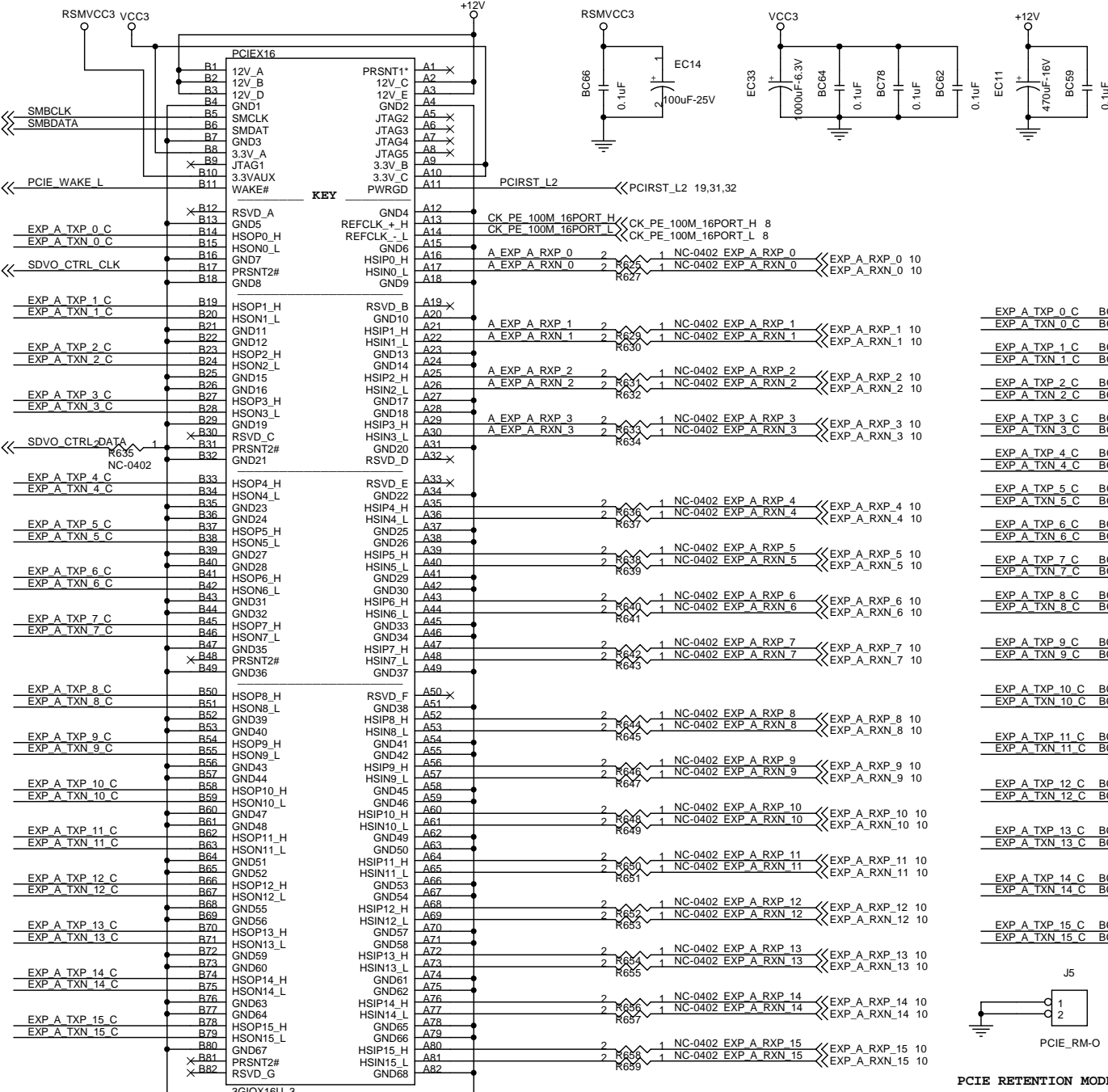
10 SDVO_CTRL_DATA





Elitegroup Computer Systems

Title		PCIE 16-PORT	Rev
Size		Document Number	
B		915GV-M7	
Date:		Friday, February 04, 2005	Sheet
		16	of 34

ICH6B

DMT

DMT EXPRESS

ICH6

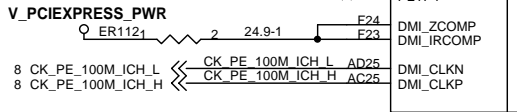
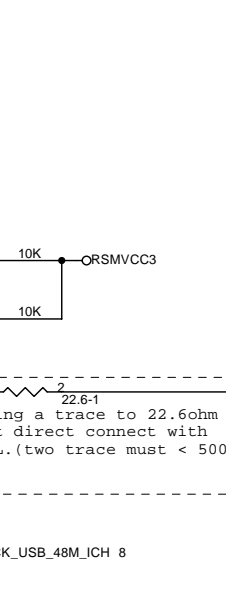
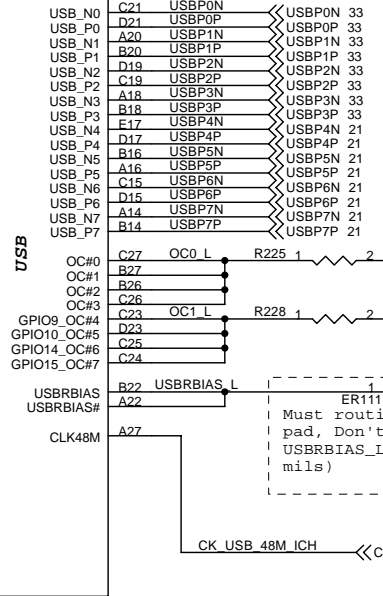
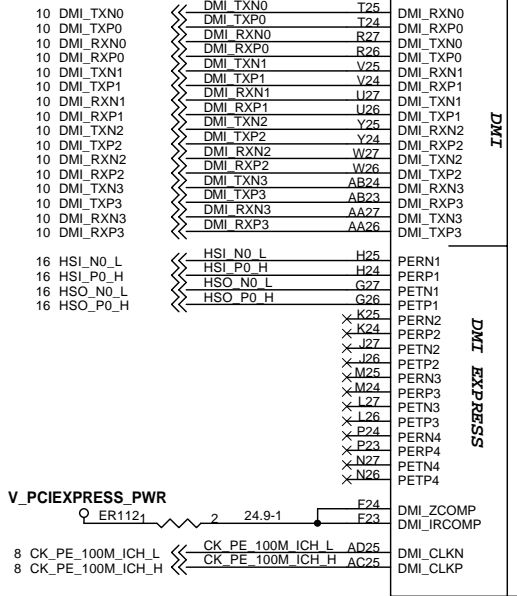

20 PDD[0..15] <- PDD[0..15]

PDD	AD	DD
PDD0	AD14	DD_0
PDD1	AE15	DD_1
PDD2	AE14	DD_2
PDD3	AD2	DD_3
PDD4	AE14	DD_4
PDD5	AC11	DD_5
PDD6	AD11	DD_6
PDD7	AB11	DD_7
PDD8	AE13	DD_8
PDD9	AE13	DD_9
PDD10	AB12	DD_10
PDD11	AB13	DD_11
PDD12	AC13	DD_12
PDD13	AE15	DD_13
PDD14	AG15	DD_14
PDD15	AD13	DD_15

PDDACK	AB	DDACK#
PDDACK_L	AB15	DDACK#
PDREQ_L	AB14	DDREQ
PDIOR_L	AE16	DDIOR#
PDIOW_L	AC14	DDIOW#
PIORDY	AE16	PIORDY

PDA	AC	DA
PDA0	AC16	DA0
PDA1	AB17	DA1
PDA2	AC17	DA2
CS1P_L	AD16	DCS#1
CS3P_L	AE17	DCS#3
IRQ14	AB16	IDEIRQ

ICH6C

SATA	AE	SATA
SATA_RXN0	AE3	SATA0RXN
SATA_RXP0	AD3	SATA0RXP
SATA_TXN0	AG2	SATA0TXN
SATA_TXP0	AE2	SATA0TXP
SATA_RXN1	AC5	SATA1RXN
SATA_RXP1	AD5	SATA1RXP
SATA_TXN1	AE4	SATA1TXN
SATA_TXP1	AG4	SATA1TXP
SATA_RXN2	AD7	SATA2RXN
SATA_RXP2	AC7	SATA2RXP
SATA_TXN2	AE6	SATA2TXN
SATA_TXP2	AG6	SATA2TXP
SATA_RXN3	AC9	SATA3RXN
SATA_RXP3	AD9	SATA3RXP
SATA_TXN3	AE8	SATA3TXN
SATA_TXP3	AG8	SATA3TXP

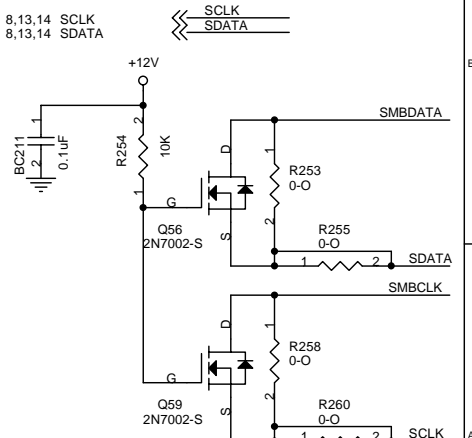
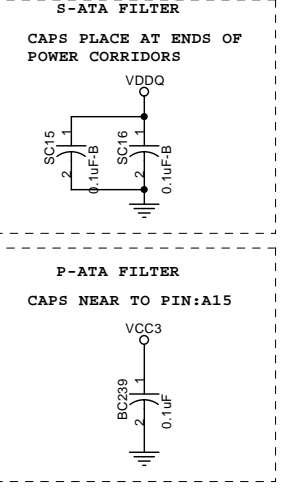
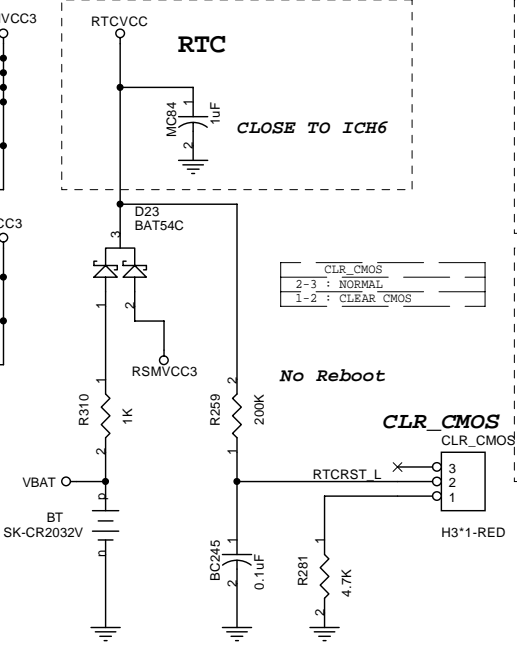
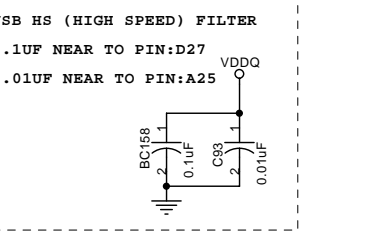
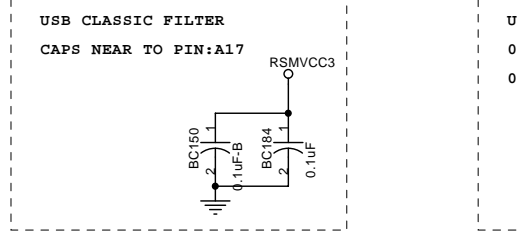
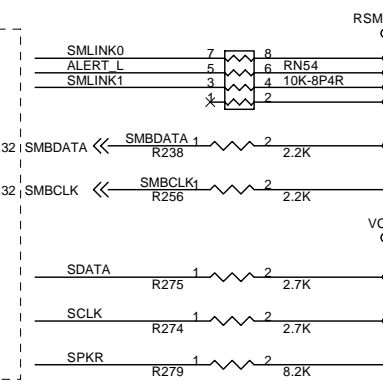
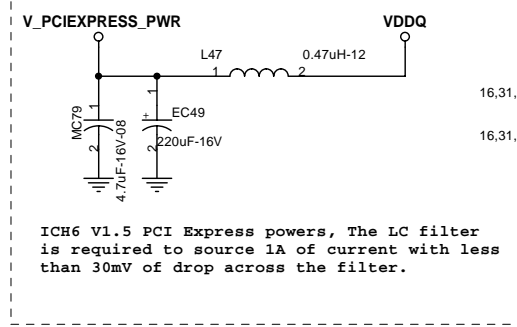
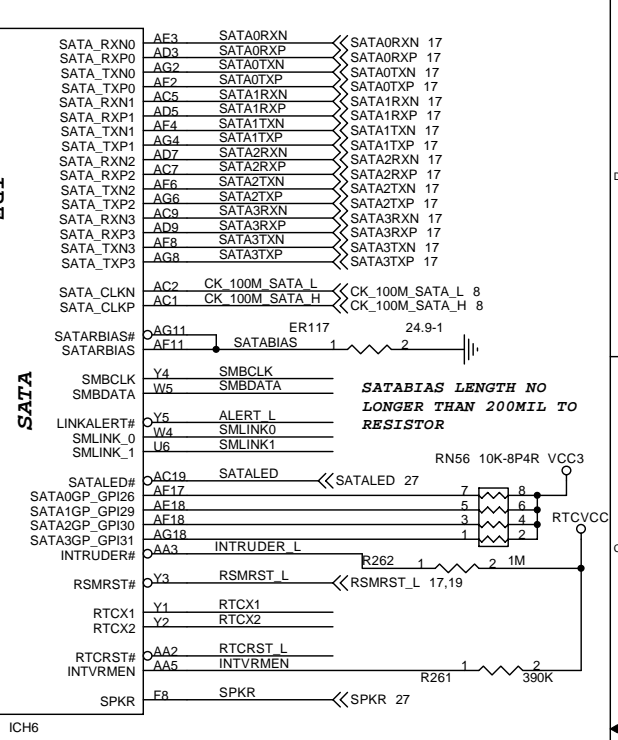

Elitegroup Computer Systems

ICH6 Part B & C

File: Custom
 Document Number: 915GV-M7
 Date: Friday, February 04, 2005
 Sheet: 18 of 34
 Rev: 1.0

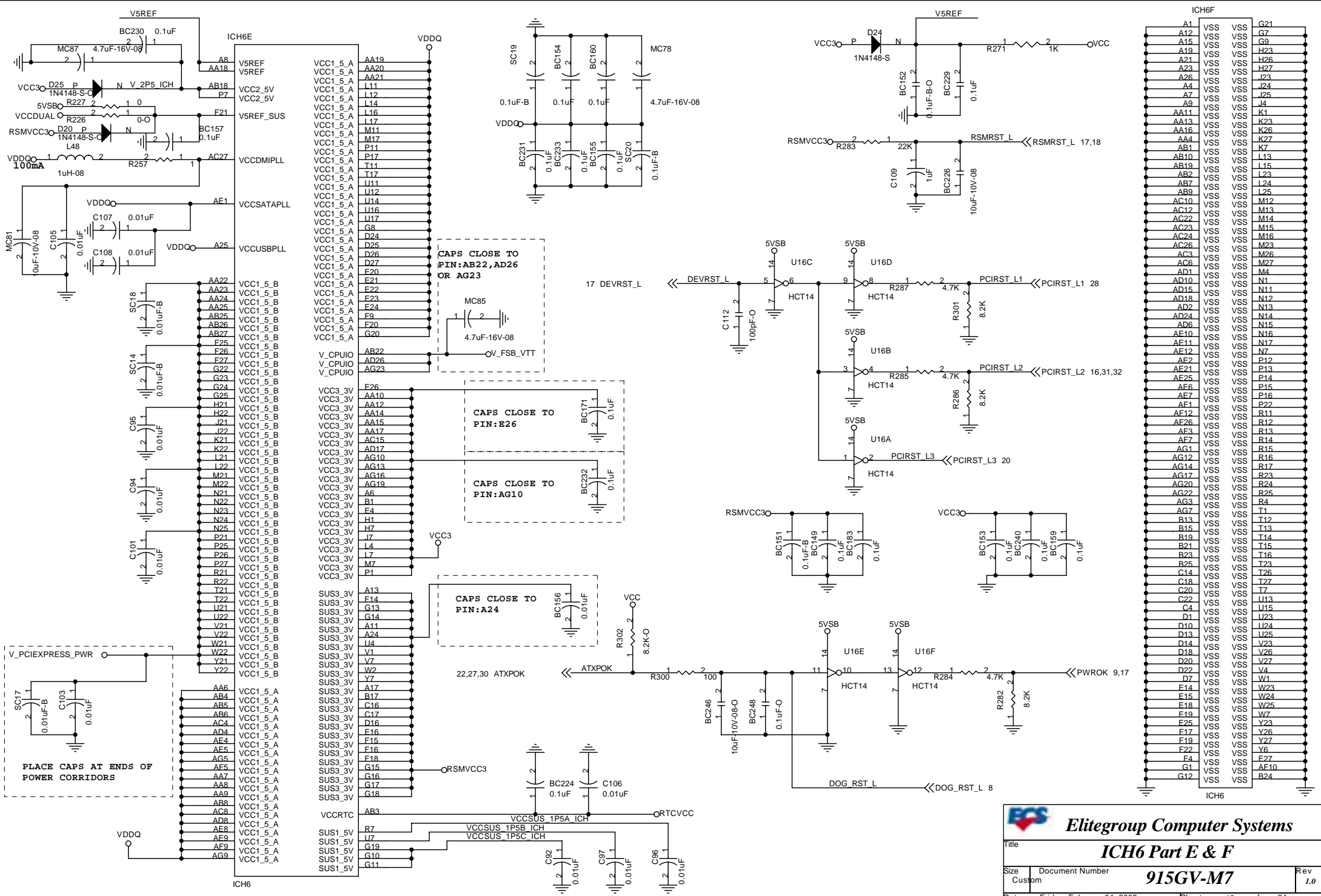

ICH6F	
A1	VSS
A12	VSS
A15	VSS
A19	VSS
A21	VSS
A23	VSS
A26	VSS
A4	VSS
A7	VSS
A9	VSS
AA11	VSS
AA13	VSS
AA16	VSS
AA4	VSS
AB1	VSS
AB10	VSS
AB19	VSS
AB2	VSS
AB7	VSS
AB9	VSS
AC10	VSS
AC12	VSS
AC22	VSS
AC23	VSS
AC24	VSS
AC26	VSS
AC3	VSS
AC6	VSS
AD1	VSS
AD10	VSS
AD15	VSS
AD18	VSS
AD2	VSS
AD24	VSS
AD6	VSS
AE10	VSS
AE11	VSS
AE12	VSS
AE2	VSS
AE21	VSS
AE25	VSS
AE6	VSS
AE7	VSS
AE1	VSS
AE12	VSS
AE26	VSS
AE3	VSS
AE7	VSS
AG1	VSS
AG12	VSS
AG14	VSS
AG17	VSS
AG20	VSS
AG22	VSS
AG3	VSS
AG7	VSS
B13	VSS
B15	VSS
B19	VSS
B21	VSS
B23	VSS
B25	VSS
C14	VSS
C18	VSS
C20	VSS
C22	VSS
C4	VSS
D1	VSS
D10	VSS
D13	VSS
D14	VSS
D18	VSS
D20	VSS
D22	VSS
D7	VSS
F14	VSS
F15	VSS
F18	VSS
F19	VSS
F25	VSS
F19	VSS
F22	VSS
F4	VSS
G1	VSS
G12	VSS
G21	VSS
G7	VSS
G9	VSS
H23	VSS
H26	VSS
H27	VSS
J24	VSS
J4	VSS
J25	VSS
J5	VSS
K1	VSS
K23	VSS
K26	VSS
K27	VSS
K7	VSS
L13	VSS
L15	VSS
L23	VSS
L24	VSS
L25	VSS
M12	VSS
M13	VSS
M14	VSS
M15	VSS
M16	VSS
M23	VSS
M26	VSS
M27	VSS
M4	VSS
N1	VSS
N11	VSS
N12	VSS
N13	VSS
N14	VSS
N15	VSS
N16	VSS
N17	VSS
N7	VSS
P12	VSS
P13	VSS
P14	VSS
P15	VSS
P18	VSS
P22	VSS
R11	VSS
R12	VSS
R13	VSS
R14	VSS
R15	VSS
R16	VSS
R17	VSS
R23	VSS
R24	VSS
R25	VSS
R4	VSS
T1	VSS
T12	VSS
T13	VSS
T14	VSS
T15	VSS
T16	VSS
T23	VSS
T26	VSS
T27	VSS
T7	VSS
U13	VSS
U15	VSS
U23	VSS
U24	VSS
U25	VSS
V23	VSS
V26	VSS
V27	VSS
V4	VSS
W1	VSS
W23	VSS
W24	VSS
W25	VSS
W7	VSS
Y23	VSS
Y26	VSS
Y27	VSS
Y6	VSS
Y27	VSS
Y6	VSS
E27	VSS
AF10	VSS
B24	VSS

Elitegroup Computer Systems

ICH6 Part E & F

Title: **915GV-M7**

Size: Custom Document Number: **915GV-M7** Rev: **1.0**

Date: Friday, February 04, 2005 Sheet: **19** of **34**

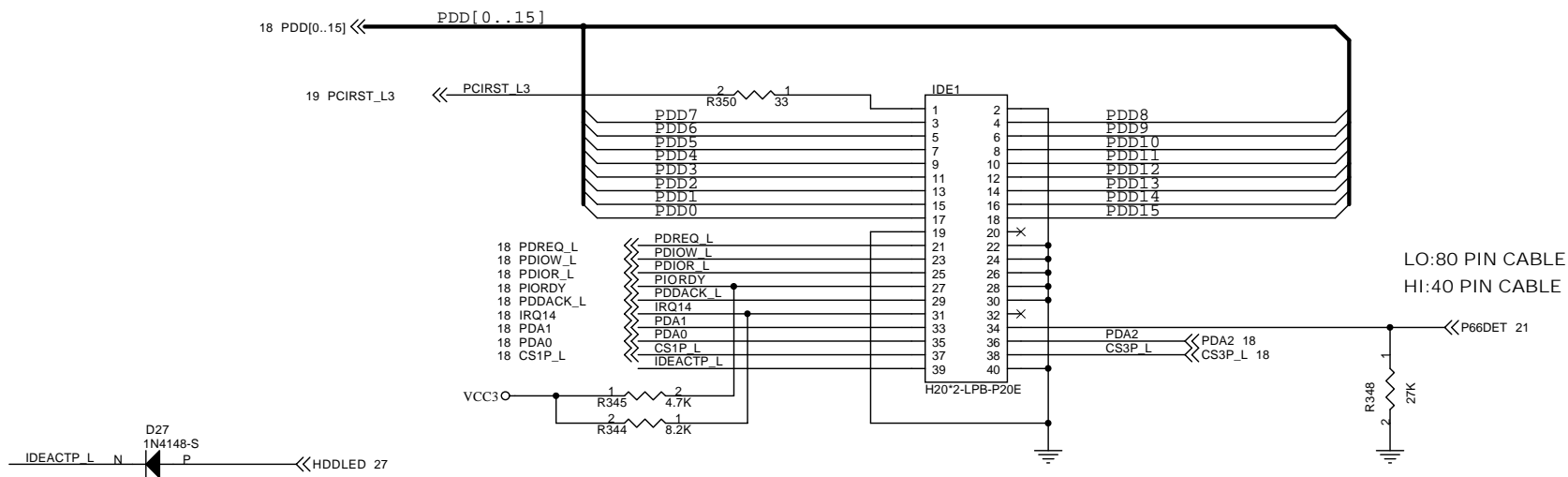

MAX TRACE LENGTH IS 8"
**DATA LINES SHOULD BE MATCHED TO STROBES (XDIOR_L, XIORDY_L) WITHIN +/- 250 MIL,
 STROBES SHOULD BE MATCHED TO THEIR COMPLEMENT WITHIN +/- 10MIL.**

 Elitegroup Computer Systems		
Title: IDE Connector		
Size: Custom	Document Number: 915GV-M7	Rev: 1.0
Date: Friday, February 04, 2005 Sheet 20 of 34		

USB PORT INTERFACE

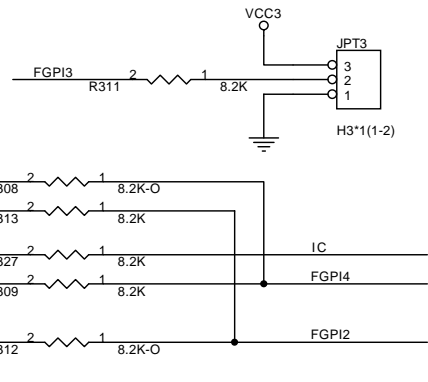
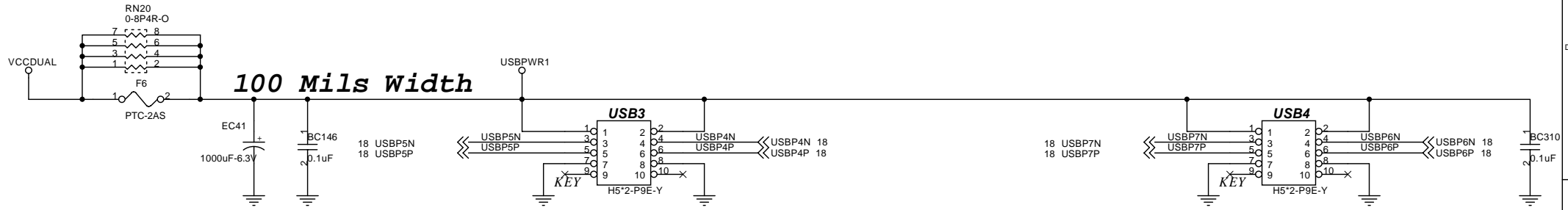

GPI1:
 High:XXX Install
 Low:XXX

GPI2:
 High:1394 Install
 Low:1394 xxx

GPI3:
 High:Suspend xxx
 Low:suspend install

GPI4:
 High:3-COM Lan Install
 Low:Realtek PCI Lan install

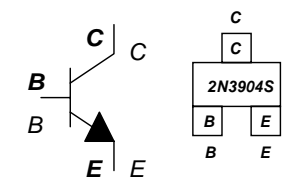
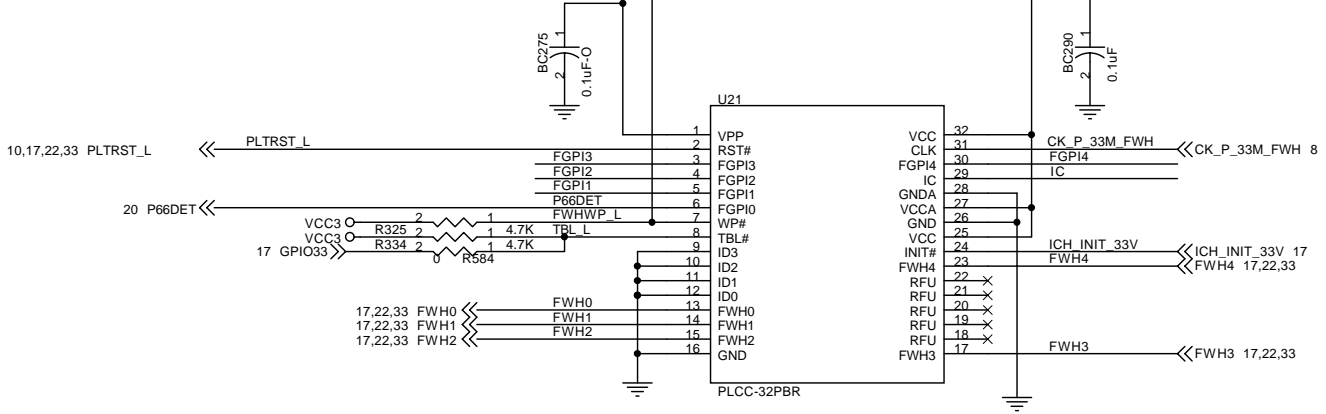
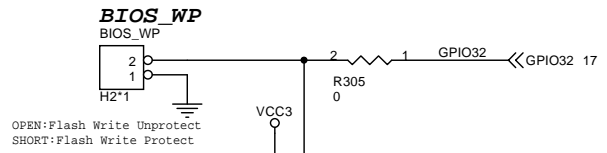
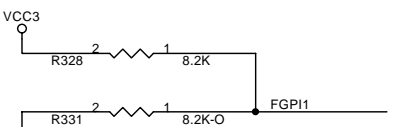
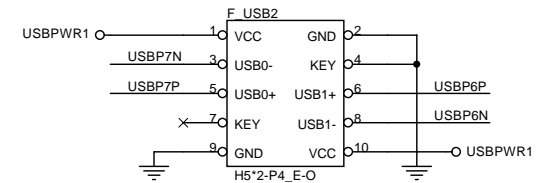
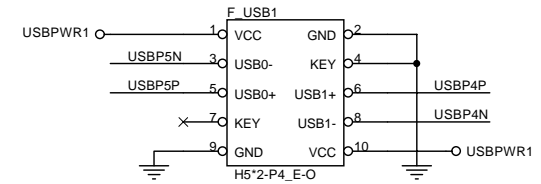

Elitegroup Computer Systems		
USB/FWH		
Size Custom	Document Number 915GV-M7	Rev 1.0
Date: Friday, February 04, 2005	Sheet 21	of 34

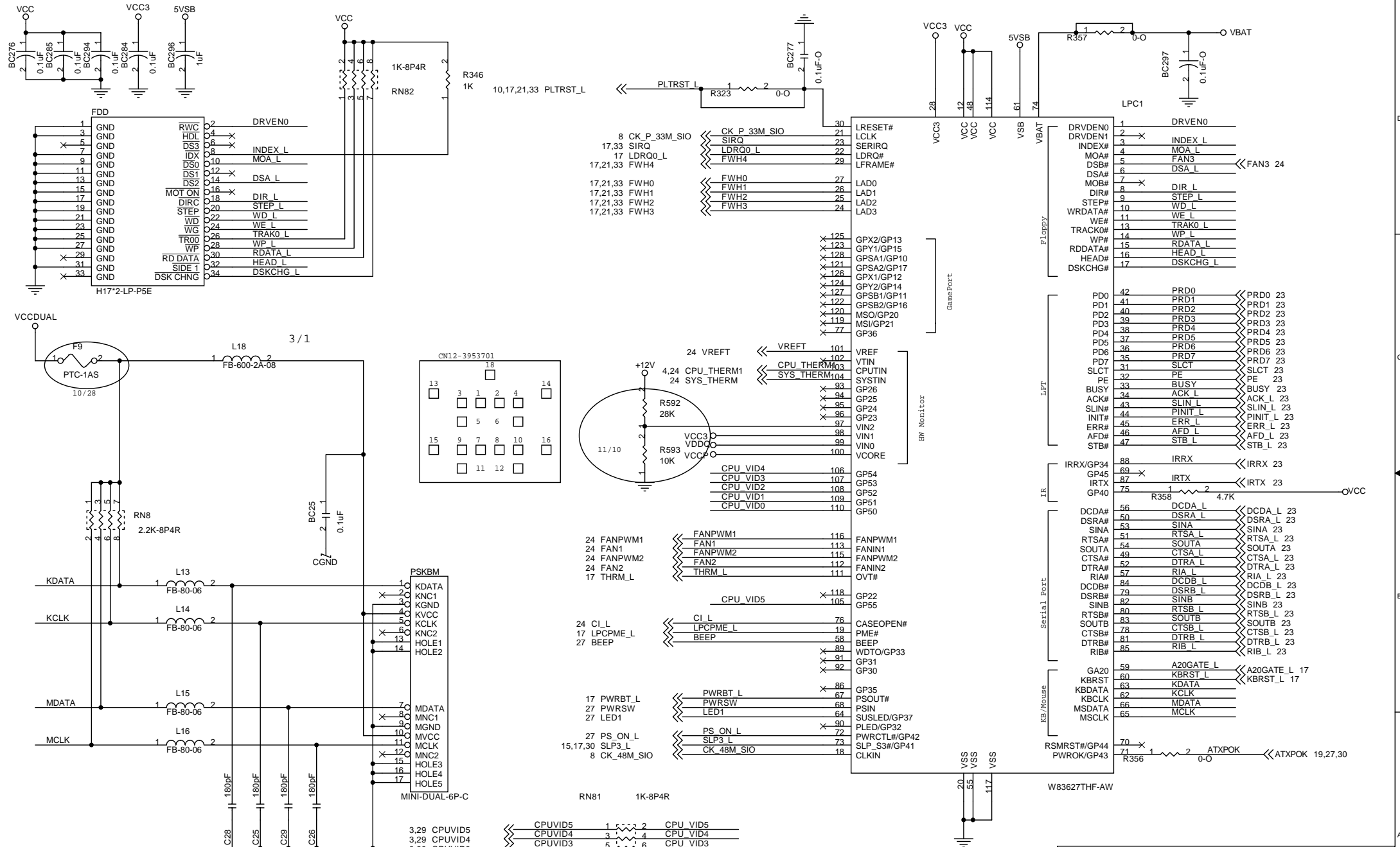



Elitegroup Computer Systems

LPC_FDD/KB/M

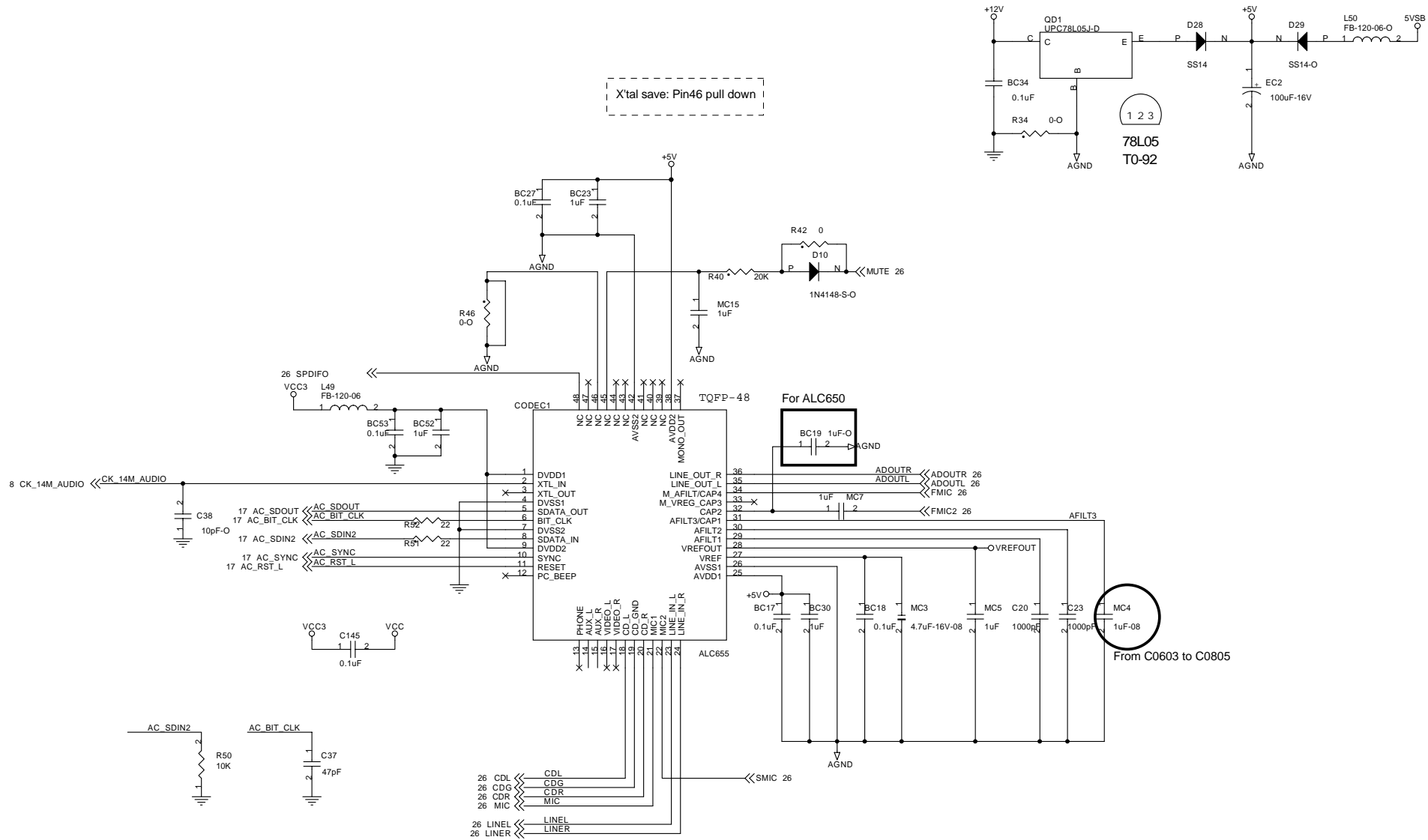
Title	LPC_FDD/KB/M		
Size	Document Number	915GV-M7	
Custom			Rev 1.0
Date:	Friday, February 04, 2005	Sheet	22 of 34

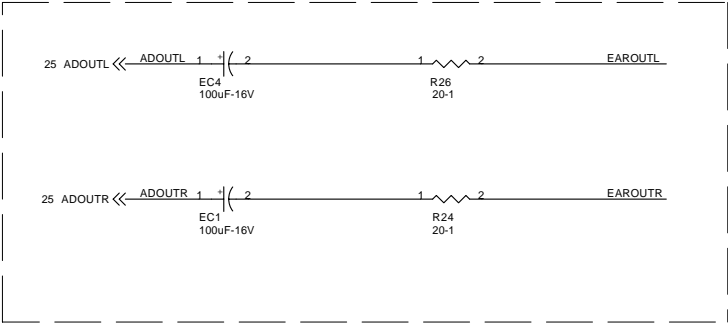

SPEAKER-OUT



LINE-IN

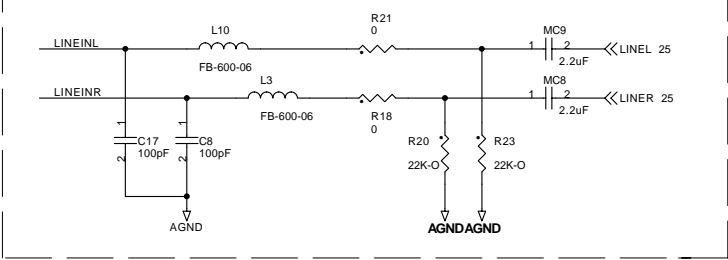

CD-IN

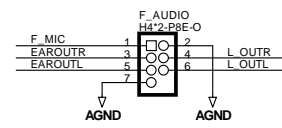
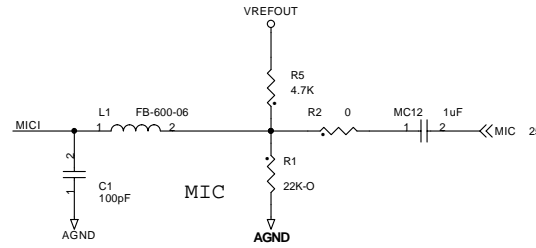
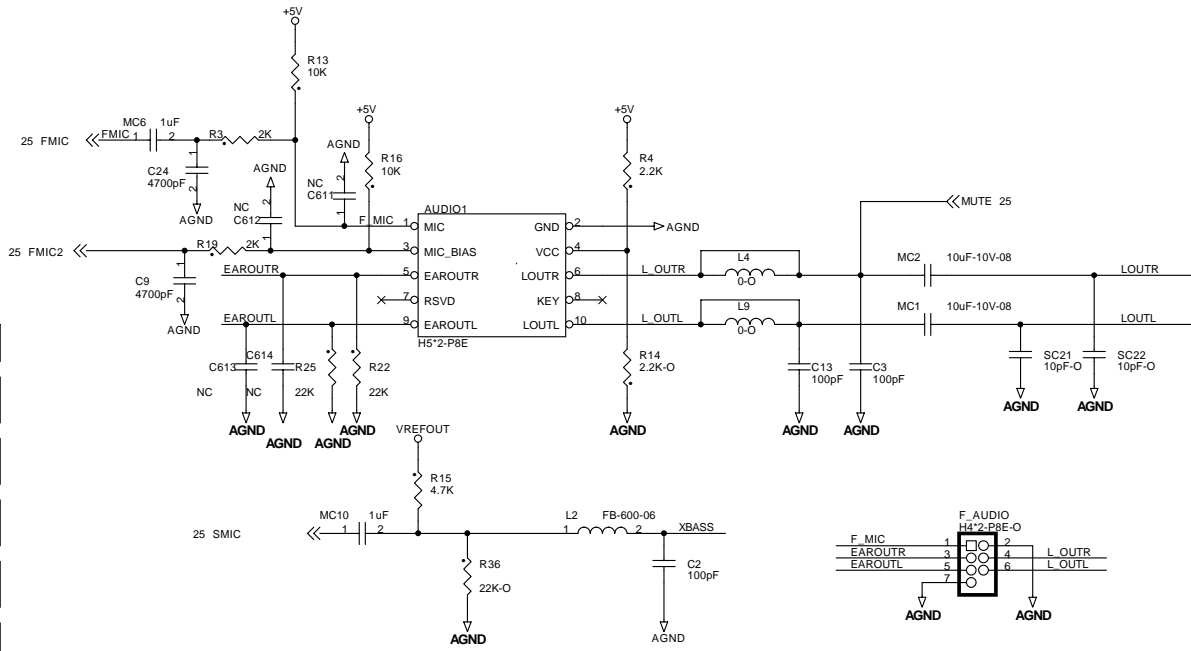
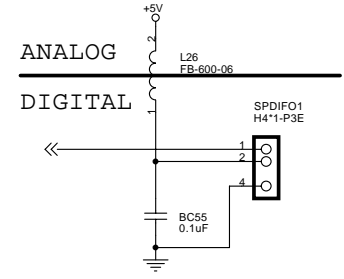
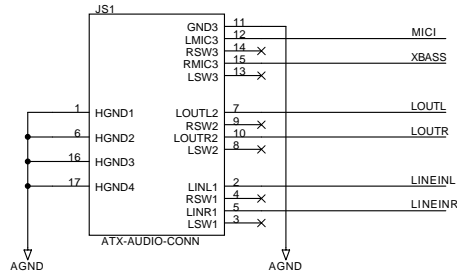
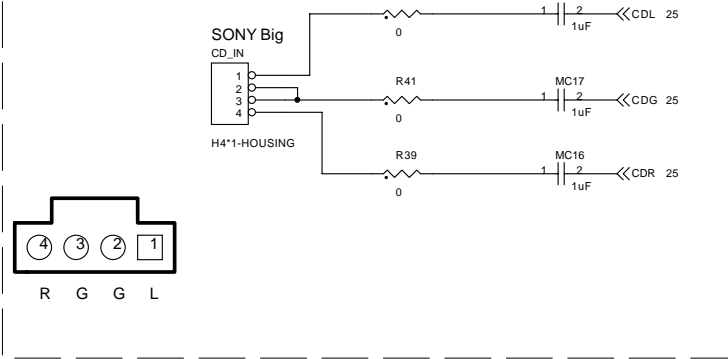

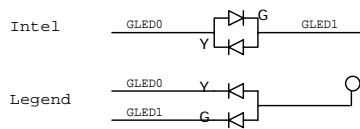
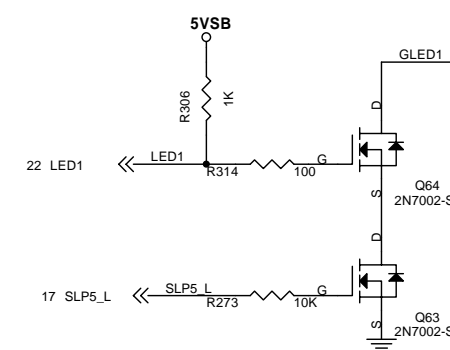
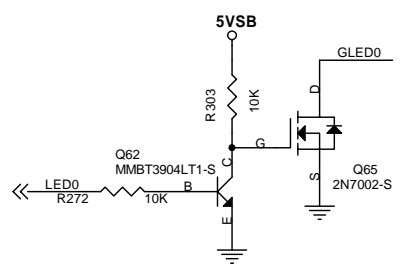
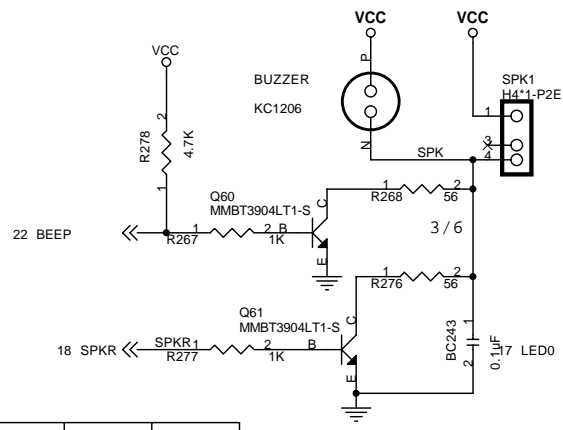
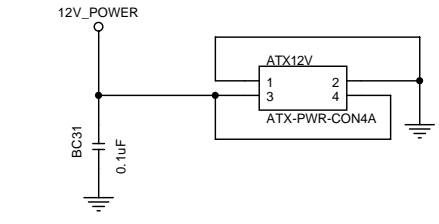
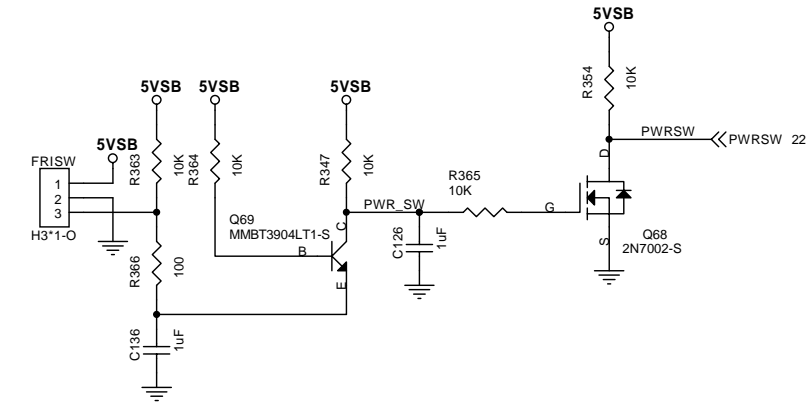
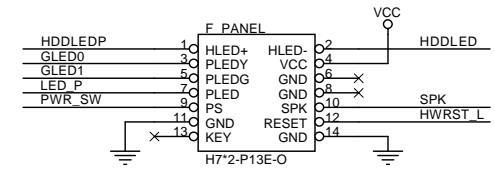
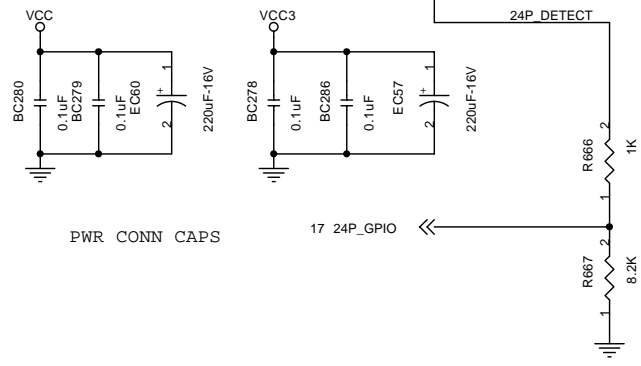
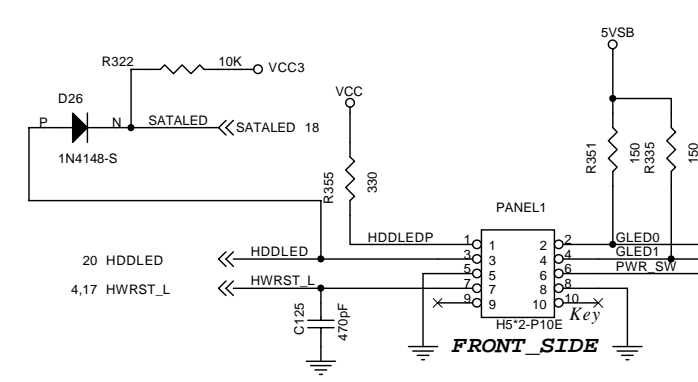
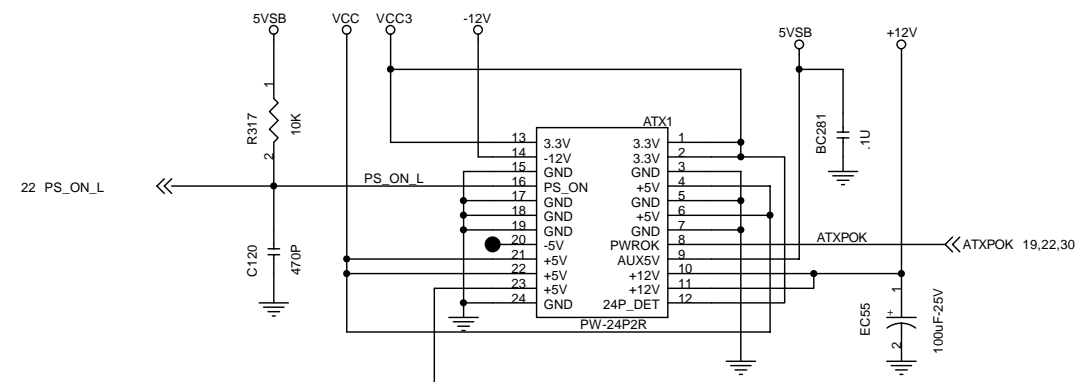

	S0	S1	S3	S4,S5
PANEL1(4,2)	Green	G-blinking	Y-blinking	Dark
LPANEL1(3,5,7)	Green	G-blinking	G-blinking Yellow	Dark
LSJ1(1,2)	Dark	Dark	Light	Dark
SJ1(1,3)(2,3)	Light	Blinking	Blinking	Dark
GLED0	HIGH	HIGH	LOW	HIGH
GLED1	LOW	SWITCH	SWITCH	HIGH

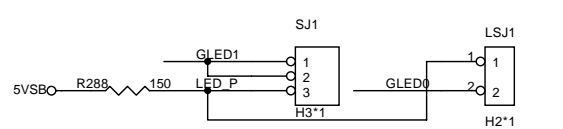
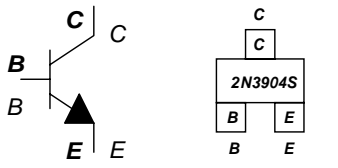

Elitegroup Computer Systems

ATX Power & Front Panel

Size B Document Number **915GV-M7** Rev 1.0

Date: Friday, February 04, 2005 Sheet 27 of 34

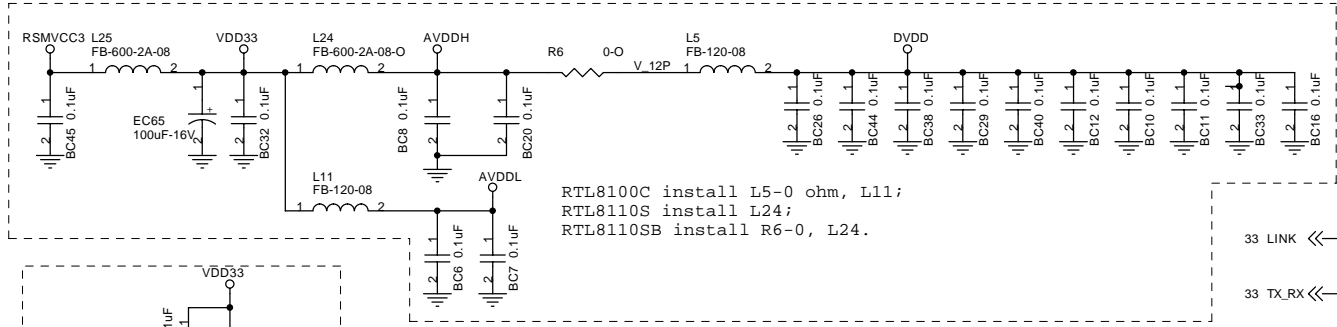

RTL8100C install L5-0 ohm, L11;
 RTL8110S install L24;
 RTL8110SB install R6-0, L24.

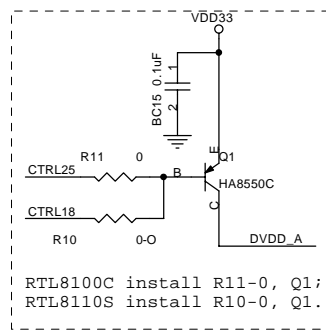

RTL8100C install R11-0, Q1;
 RTL8110S install R10-0, Q1.

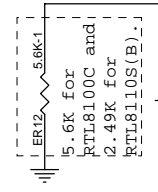
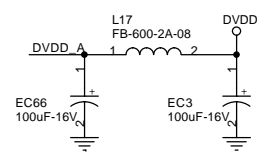

Install only for
 RTL8110SB,
 NC for
 RTL8100C &
 RTL8110S.

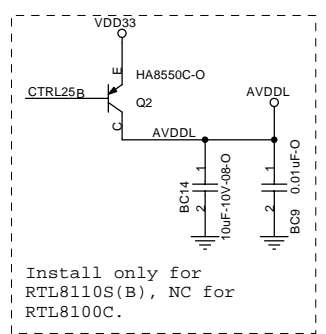

Install only for
 RTL8110S(B), NC for
 RTL8100C.

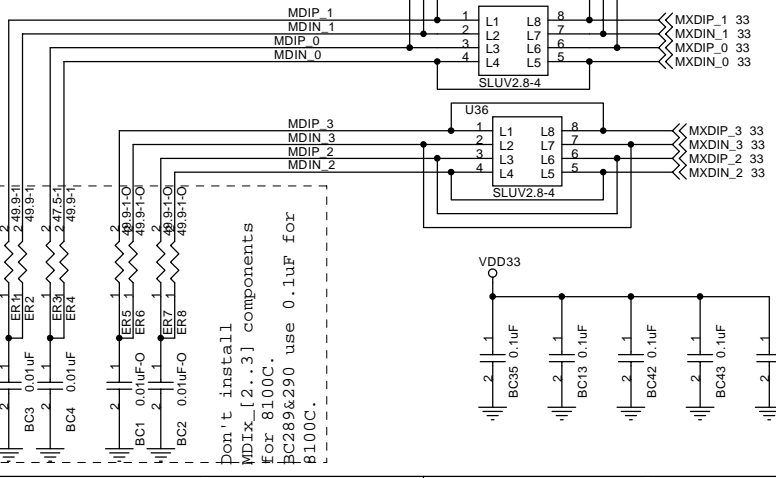

Don't install
 MDIx_{2..3} components
 for 8100C.
 BC289&290 use 0.1uF for
 B100C.

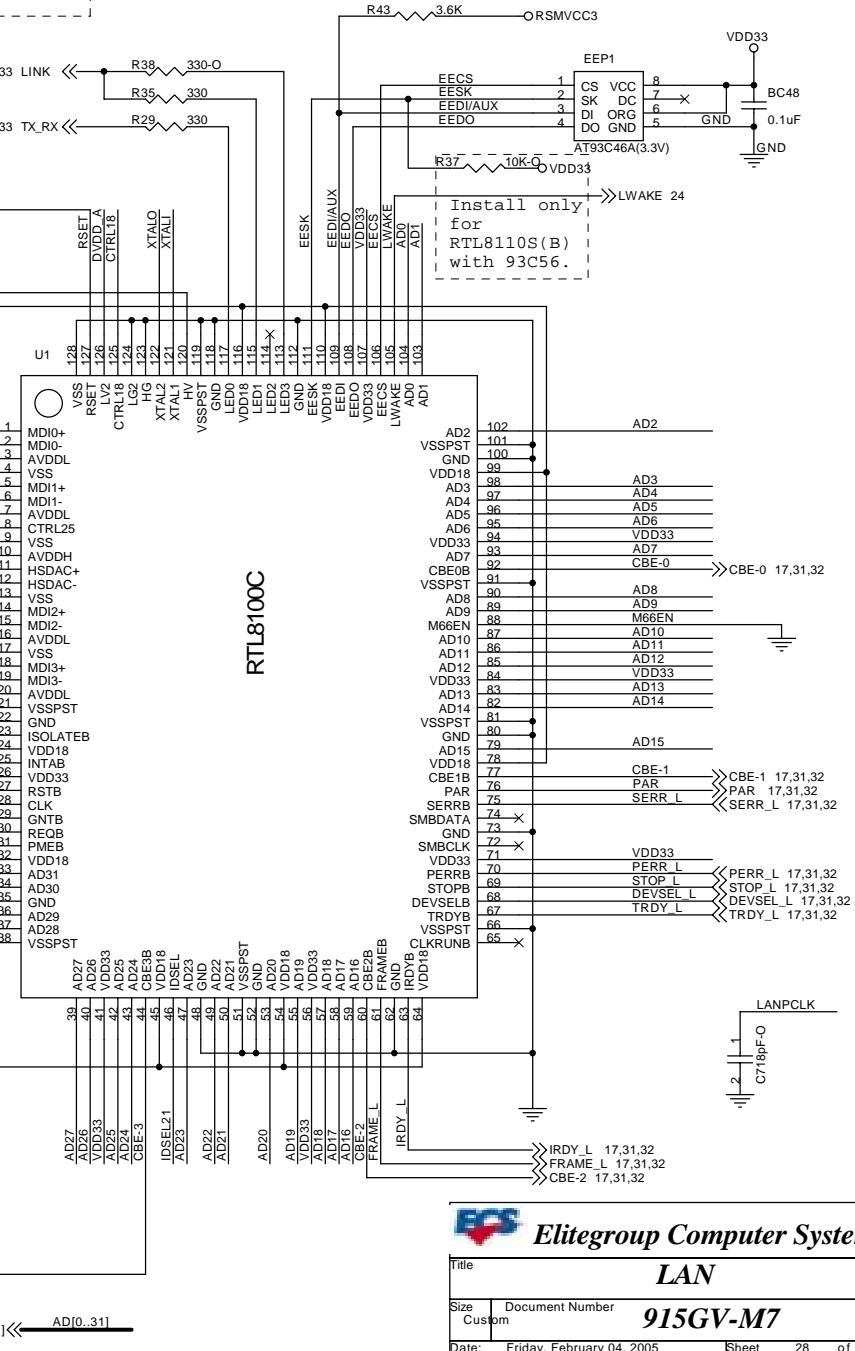
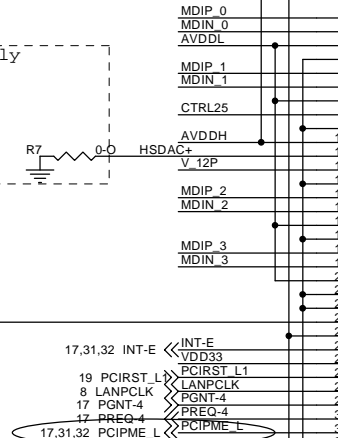
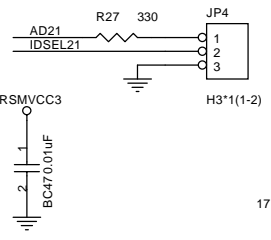

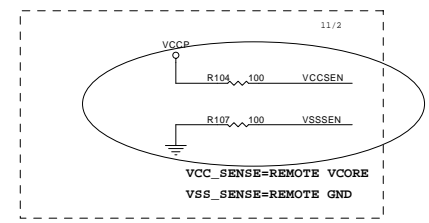
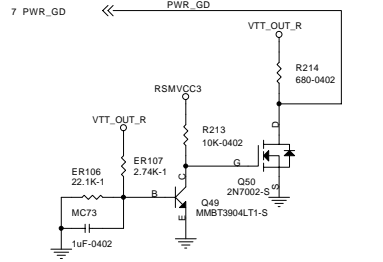
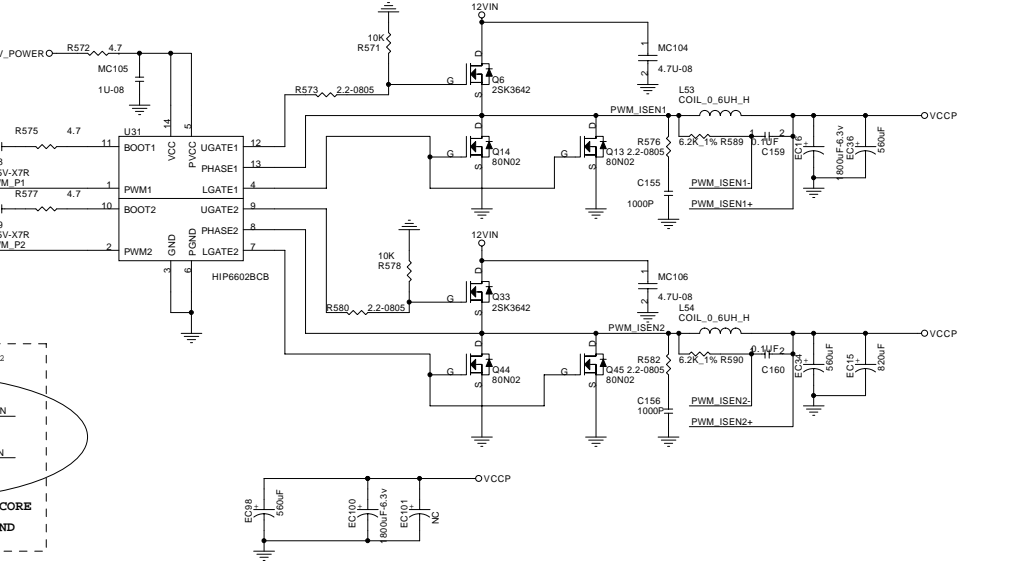
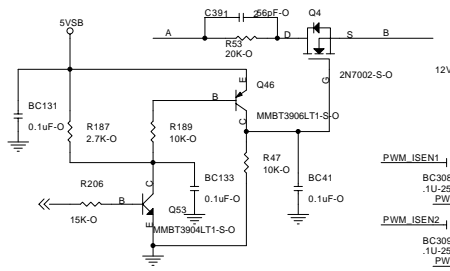
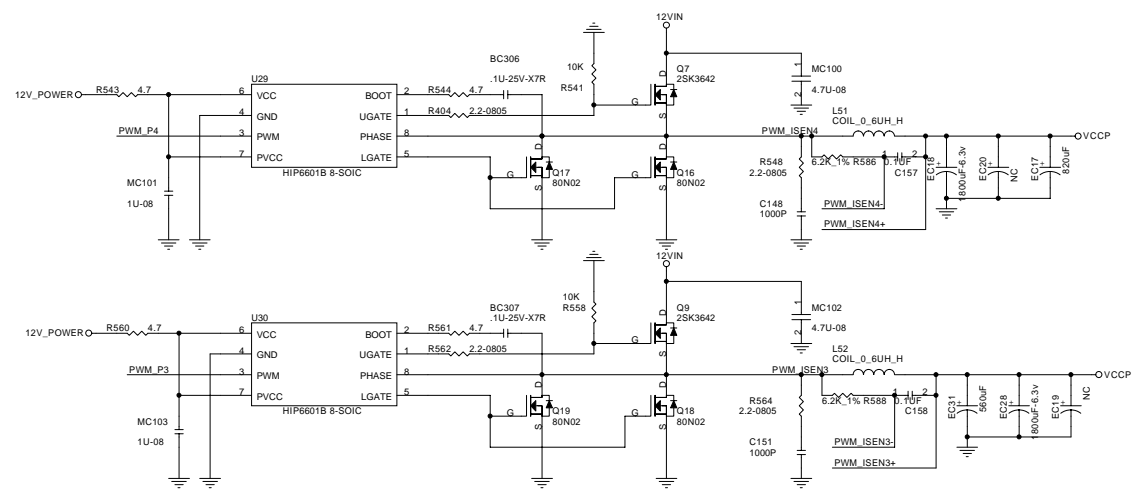
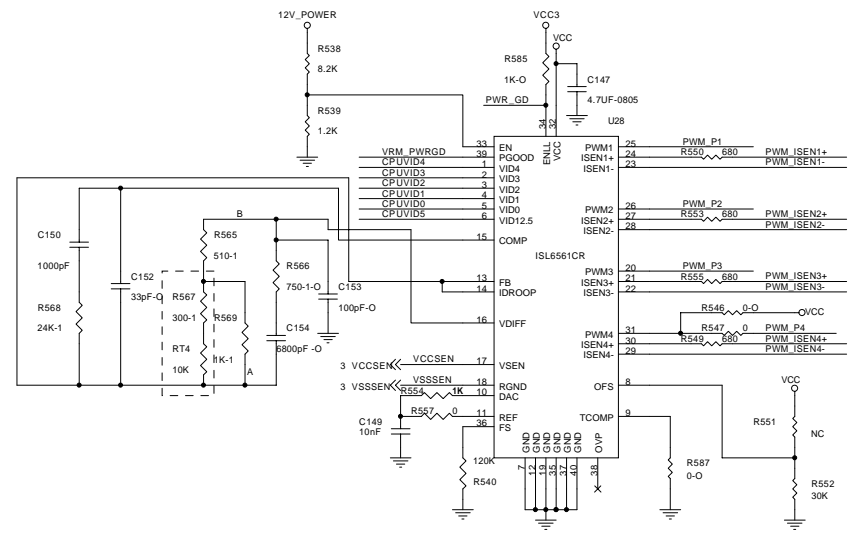
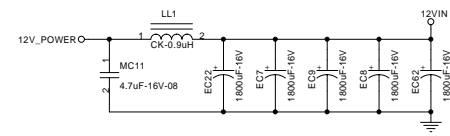
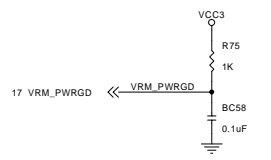
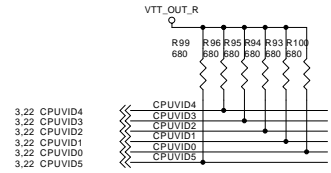

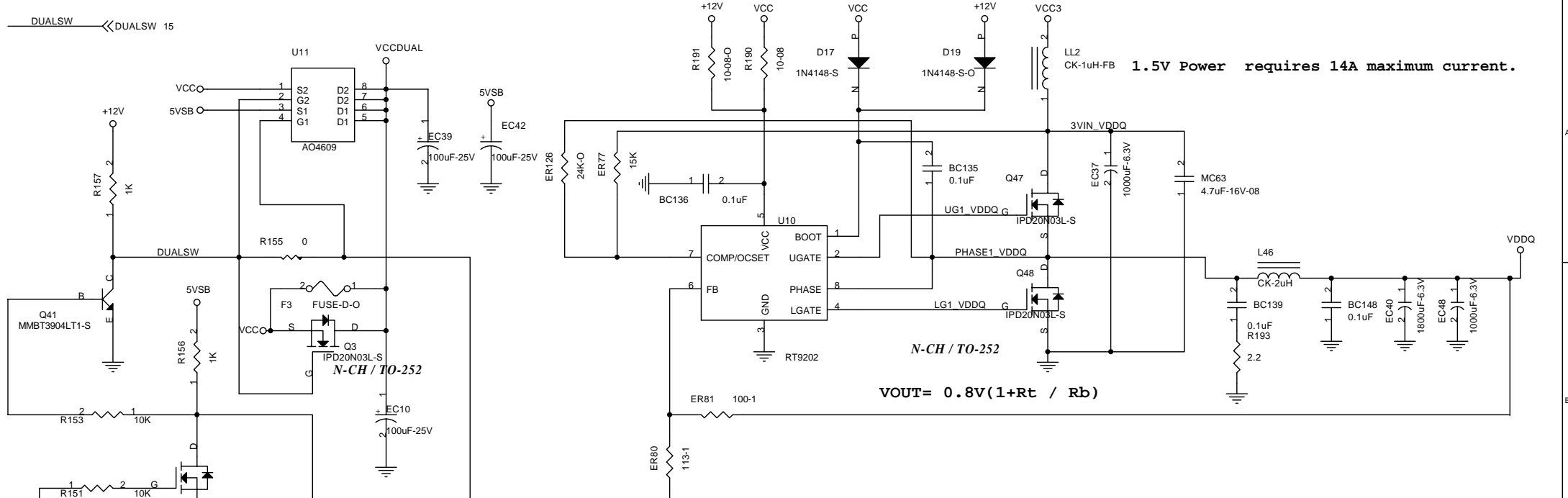

$$V_{OUT} = 0.8V(1 + R_t / R_b)$$

Signal Mode	GPIO23	VCCDUAL
S4/S5	0	0 (No Power)
S4/S5	1	1 (5VSB)

3.3V DUAL

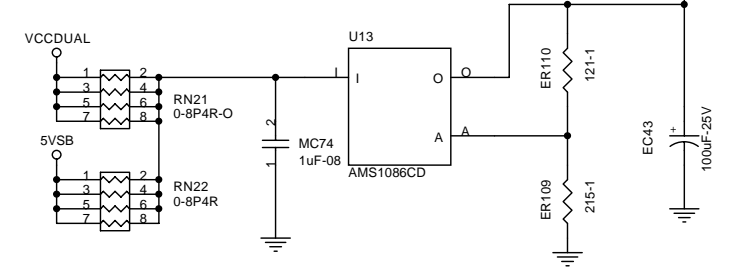

2.6V DUAL

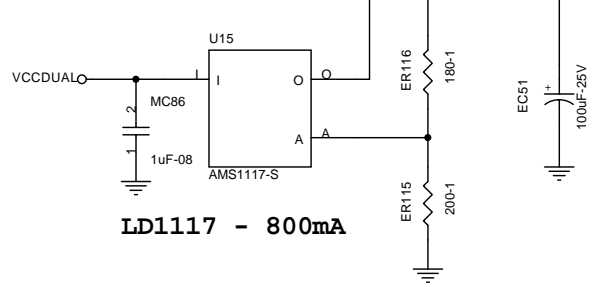

VCC26SB needs supply 570mA of current.



Title		MIS DC-DC	
Size	Document Number	915GV-M7	
Custom		Rev	1.0
Date:	Friday, February 04, 2005	Sheet	30 of 34

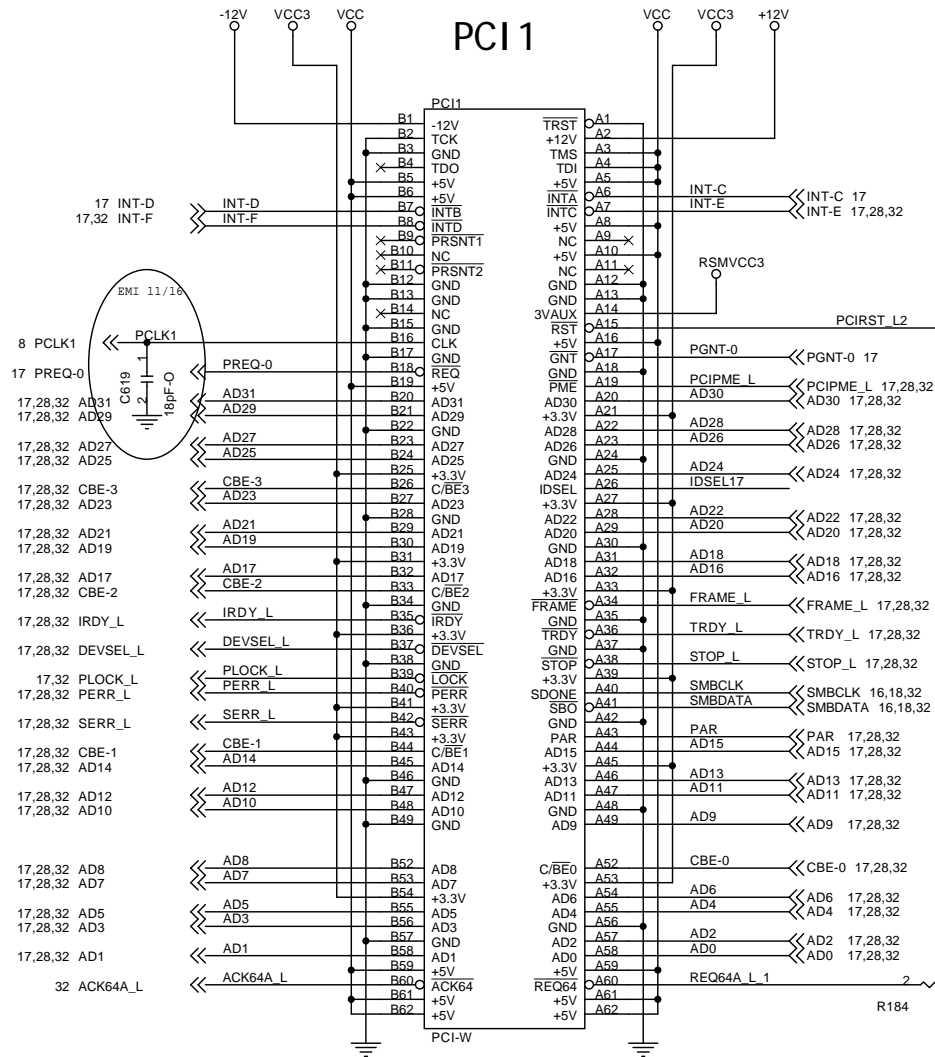

PCI1-INT : IDSEL=AD17
INTA:INTC REQ=PREQ0#
INTB:INTD GNT=PGNT0#
INTC:INTE
INTD:INTF

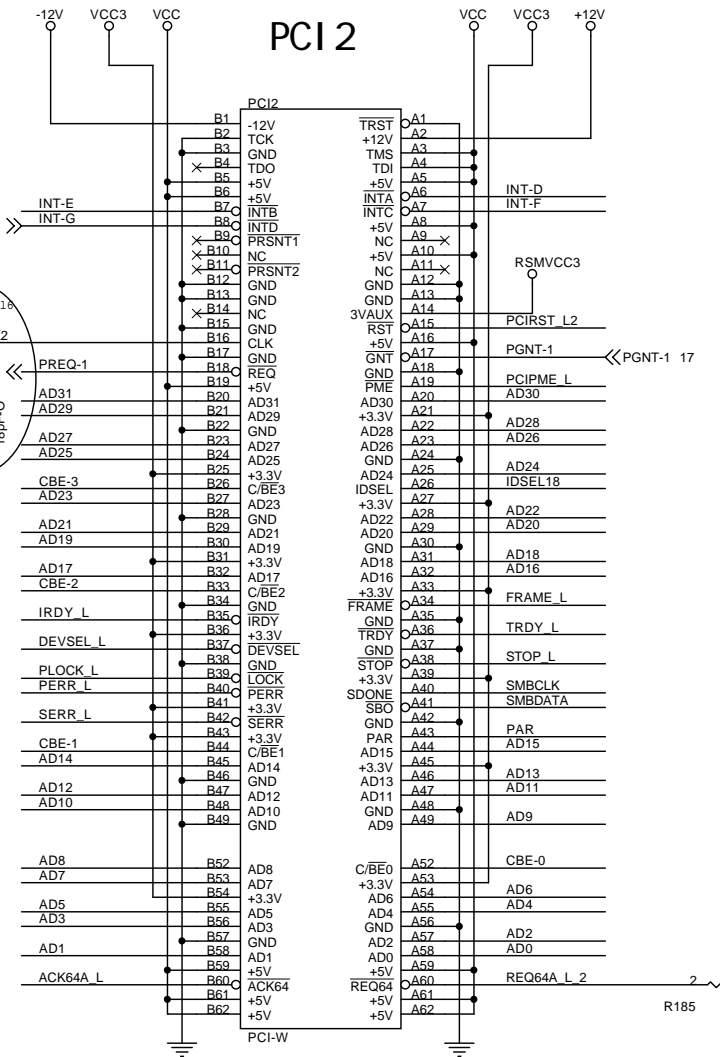
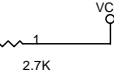
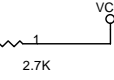
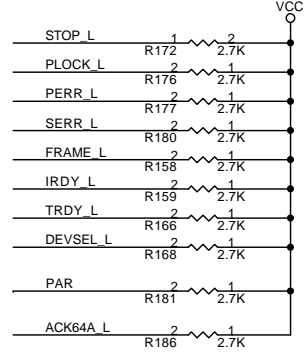
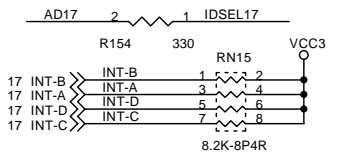

PCI2-INT : IDSEL=AD18
INTA:INTD REQ=PREQ1#
INTB:INTE GNT=PGNT1#
INTC:INTF
INTD:INTG

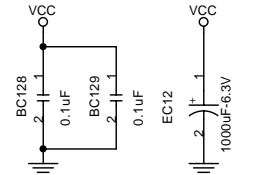
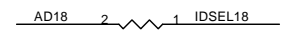

PCI Slot 1&2		
Size	Document Number	Rev
Custom	915GV-M7	L.0
Date:	Friday, February 04, 2005	Sheet 31 of 34

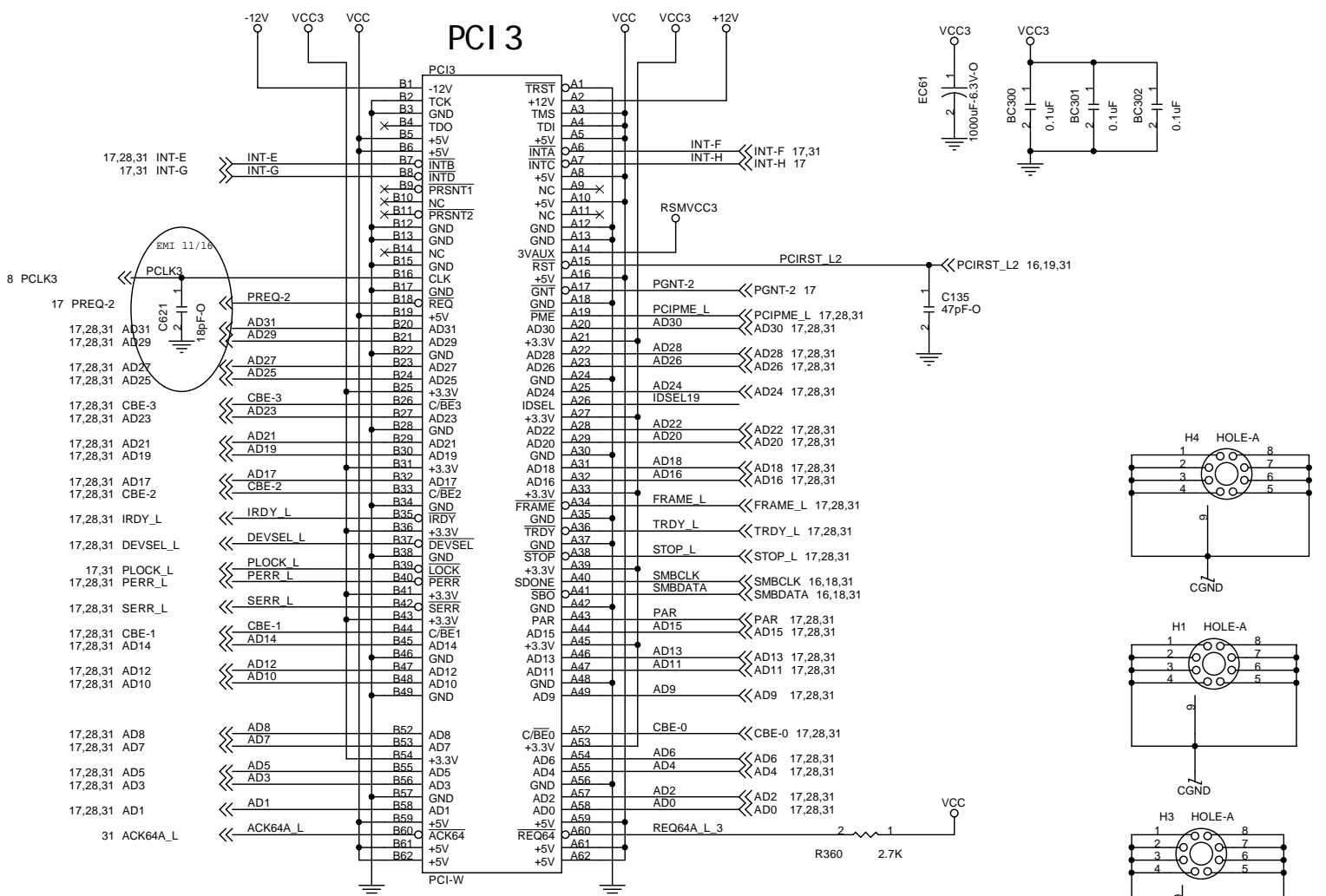

PCI 3-INT: IDSEL=AD19
 INTA: INTE REQ=PREQ2#
 INTB: INTF GNT=PGNT2#
 INTC: INTG
 INTD: INTH

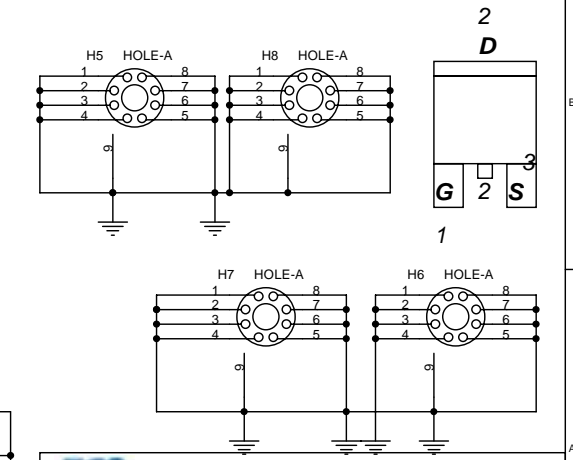
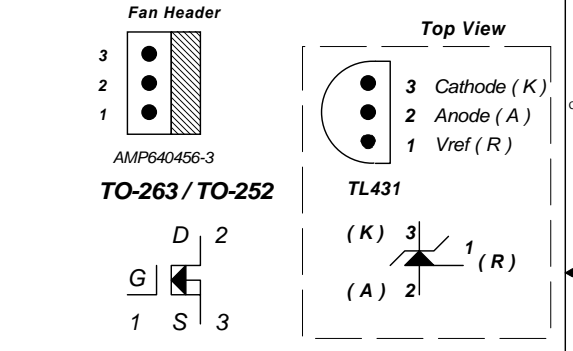
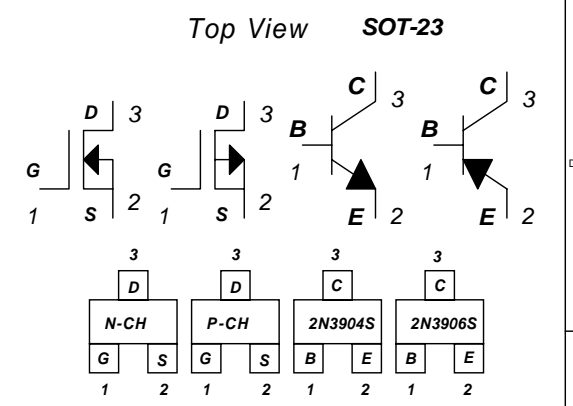
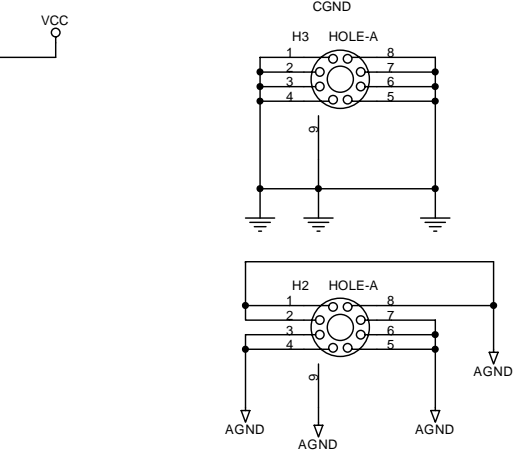
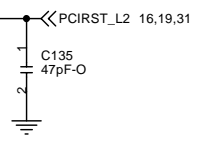
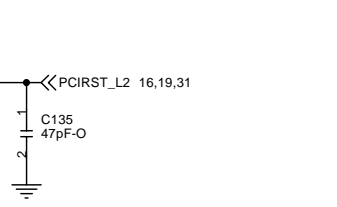
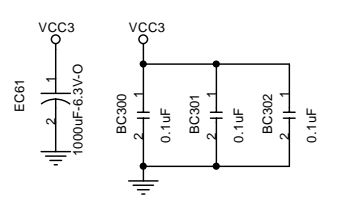
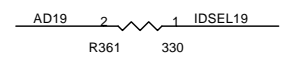

Elitegroup Computer Systems
 Title: **PCI Slot 3**
 Size B Document Number: **915GV-M7** Rev 1.0
 Date: Friday, February 04, 2005 Sheet 32 of 34

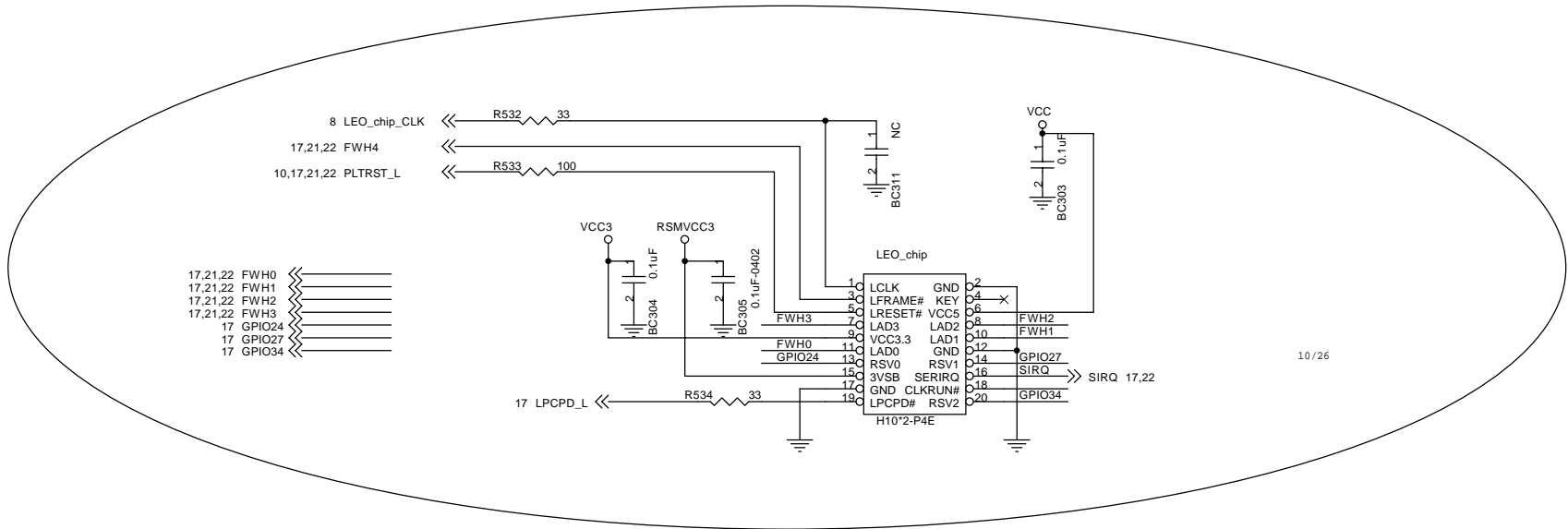

10/26

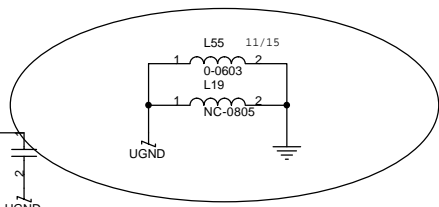
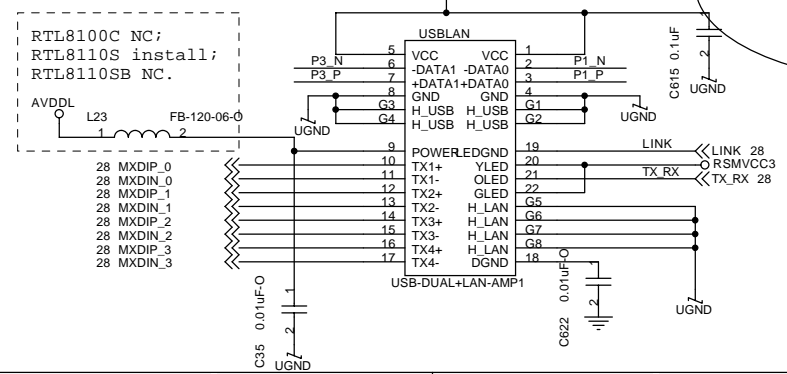
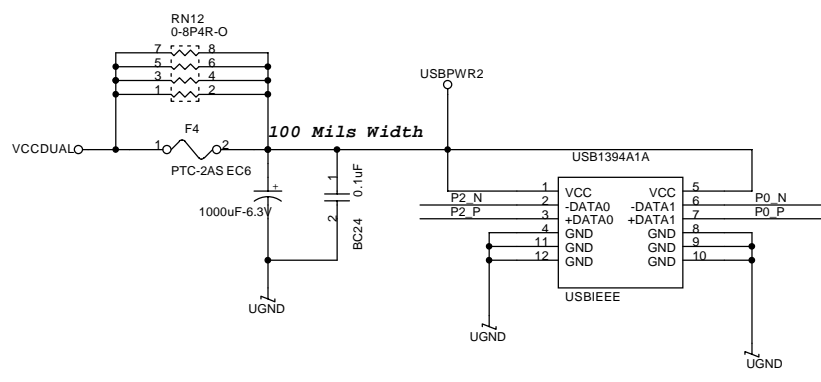
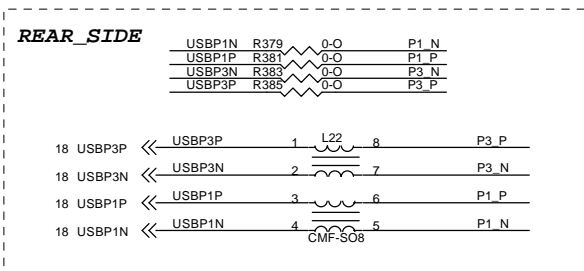
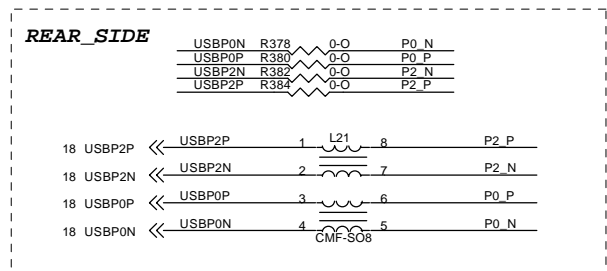

Elitegroup Computer Systems

Title: **Back I/O**

Size: Custom | Document Number: **915GV-M7** | Rev: 1.0

Date: Friday, February 04, 2005 | Sheet: 33 of 34

1 2 3 4 5 6 7 8

A

A

B

B

C

C

D

D

 Elitegroup Computer Systems		
Title Schematic Change History		
Size	Document Number	Rev
Custom	915GV-M7	1.0
Date:	Friday, February 04, 2005	Sheet 34 of 34

1 2 3 4 5 6 7 8