



PL-2507C Hi-Speed USB 2.0 to IDE Bridge Controller Product Datasheet

Document Revision: 1.3

Document Release: July 7, 2005

Prolific Technology Inc.

7F, No. 48, Sec. 3, Nan Kang Rd.
Nan Kang, Taipei 115, Taiwan, R.O.C.

Tel: 886-2-2654-6363

Fax: 886-2-2654-6161

Email: sales@prolific.com.tw

URL: <http://www.prolific.com.tw>

Support: <http://tech.prolific.com.tw>



Revision History

Revision	Description	Date
1.3	Section 2.2: Added Pin Type Abbreviation Section 6.0: Modify DC Characteristics	July 7, 2005
1.2D	Section 1.0: Modify Features information	May 31, 2005
1.2C	Section 8.2: Correct LQFP64 (7x7mm) Outline Diagram	May 17, 2005
1.2B	Add Lead-Free Ordering Information	March 9, 2005
1.2	Added LQFP64 7x7 Packaging Outline Diagram	October 21, 2004
1.1	Correct Section 5.0 External Serial Memory – “Port3_3” to “Port1_0”.	April 28, 2004
1.0	Formal Release – PL2507C Hi-Speed USB 2.0 to IDE Bridge Controller (For Controller Chip Revision C ONLY)	February 25, 2004

Table of Contents

1.0 PRODUCT OVERVIEW	6
1.1 OVERVIEW	6
1.2 FEATURES	6
1.3 BLOCK DIAGRAM	7
2.0 PIN ASSIGNMENT & DESCRIPTION	8
2.1 PIN ASSIGNMENT FOR LQFP64 PACKAGE	8
2.2 USB2.0 PHY RELATED PINS.....	9
2.3 IDE INTERFACE RELATED PINS.....	9
2.4 IDE INTERFACE RELATED PINS.....	10
2.5 SYSTEM PINS.....	10
3.0 USB PORT DESCRIPTOR FOR PL-2507C	11
3.1 DEVICE DESCRIPTOR	11
3.2 CONFIGURATION DESCRIPTOR.....	12
3.3 INTERFACE DESCRIPTORS	12
3.4 ENDPOINT DESCRIPTORS	13
3.5 DEVICE_QUALIFIER DESCRIPTORS	14
3.6 OTHER_SPEED_CONFIGURATION DESCRIPTORS.....	14
4.0 DEVICE CONTROL REQUESTS	15
4.1 STANDARD DEVICE CONTROL REQUESTS.....	15
4.2 CLASS SPECIFIC REQUESTS.....	15
4.3 VENDOR SPECIFIC REQUESTS.....	16
5.0 EXTERNAL SERIAL MEMORY	17
5.1 EXTERNAL SERIAL MEMORY	17
5.2 DATA STRUCTURE OF EXTERNAL SERIAL MEMORY CONTENT	18
6.0 DC CHARACTERISTICS	20
6.1 ABSOLUTE MAXIMUM RATINGS	20
6.2 OPERATING CURRENT PARAMETERS.....	20
6.3 RECOMMENDED OPERATING CONDITIONS	20
6.4 LEAKAGE CURRENT AND CAPACITANCE ₍₃₎	20

6.5 DC CHARACTERISTICS OF 3.3V PROGRAMMABLE I/O CELLS.....	21
7.0 ORDERING INFORMATION.....	21
8.0 OUTLINE DIAGRAM	22
8.1 LQFP64 PACKAGE (10X10) OUTLINE DIAGRAM.....	22
8.2 LQFP64 PACKAGE (7X7) OUTLINE DIAGRAM.....	23

List of Figures

Figure 1-1 Block Diagram of PL-2507C	7
Figure 2-1 Pin Assignment Diagram of PL-2507C LQFP64.....	8
Figure 5-1 External Serial Memory Implementation.....	17
Figure 8-1 Outline Diagram of PL-2507C LQFP64 (10x10mm)	22
Figure 8-2 Outline Diagram of PL-2507C LQFP64 (7x7mm).....	23

List of Tables

Table 2-2 USB2.0 PHY Related Pins	9
Table 2-3 IDE Interface Related Pins.....	9
Table 2-4 IDE Interface Related Pins.....	10
Table 2-5 System Pins	10
Table 3-1 Device Descriptor	11
Table 3-2 Configuration Descriptor	12
Table 3-3 Interface Descriptors	12
Table 3-4-1a Bulk Out Endpoint Descriptor (Endpoint 1)	13
Table 3-4-1b Bulk In Endpoint Descriptor (Endpoint 2).....	13
Table 3-4-2a Bulk Out Endpoint Descriptor (Endpoint 1)	13
Table 3-4-1b Bulk In Endpoint Descriptor (Endpoint 2).....	13
Table 3-5 Device Qualifier Descriptors.....	14
Table 3-6 Other Speed Configuration Descriptors	14
Table 4-2 Class Specific Requests.....	15
Table 4-3 Vendor Specific Requests	16
Table 5-2a EEPROM Address and Content	18
Table 5-2b String Descriptor Data Structure.....	18
Table 5-2c Example of Valid EEPROM Contents.....	19
Table 6-1 Absolute Maximum Ratings.....	20
Table 6-2 Operating Current Parameters.....	20
Table 6-3 Recommended Operating Conditions	20
Table 6-4 Leakage Current and Capacitance.....	20
Table 6-5 DC Characteristics of 3.3V Programmable I/O Cells.....	21
Table 7-1 Ordering Information	21

1.0 Product Overview

1.1 Overview

The PL-2507C is a single chip Hi-Speed USB-to-IDE bridge controller that is designed to perform seamless protocol transfer between the USB and ATA interface. The operating speed is determined by the capability of the host/hub it is connected to. PIO mode 0 to mode 4, Multi Word DMA mode 0 to mode 2, and Ultra DMA mode 0 to mode 4 are implemented to support broad range of standard ATA and ATAPI devices. The PL-2507C also supports two devices at the same time using Master/Slave mode and upgradeable firmware using large EEPROM or SPI Flash. To obtain the best performance possible, the PL-2507C negotiates with the connected device(s) to select the proper mode supported by the device. The PL-2507C is implemented according to the USB Bulk-Only Mass Storage Class specification v1.0 so the USB mass storage driver is already built inside most OSes.

1.2 Features

- AT Attachment with Packet Interface Extension (ATA/ATAPI-6) Compliant
- ATA interface support PIO mode 0~4, Multiword DMA mode 0~2, and Ultra-DMA mode 0~4 to work with ATA/ATAPI devices.
- Universal Serial Bus Specification 2.0 Compliant
- USB Mass Storage Class Bulk-Only Transport Specification Compliant. No drivers needed in Linux (kernel 2.4.18 or above), Mac OS 9.x or above, Windows ME, 2000, XP, 2003 or above. Windows 98 requires additional driver installation provided by Prolific.
- Integrated the full speed (12Mbps) and high speed (480Mbps) transceiver
- Sufficient 4K bytes data buffer for both the downstream and upstream data transfer in optimized performance.
- Single or two ATA/ATAPI devices are supported
- Master or Slave ATA/ATAPI device(s) is detected automatically. Single device can be configured as master or slave device.
- Support multiple LUN (optional)
- Vendor/Product related information could be customized by external SPI serial Flash or external I2C compatible serial EEPROM.
- Content of serial EEPROM or serial Flash can be updated through USB interface
- Firmware can be upgraded easily through USB interface if large serial EEPROM or serial Flash is used.
- Multi-function General Purpose IO pins has defined for USB speed LED, button inputs, etc.
- GPIO pins can also be customized by external serial memory or through USB interface
- Low power consumption allows for bus-powered or self-powered operation
- Low power 2.5V core operating voltage
- On-chip 3.3V to 2.5V regulator to supply the power for core circuit
- 5V tolerant inputs, 3.3V output drive
- Single inexpensive 12-MHz crystal for clock source
- Inexpensive LQ64 packaging available in 10x10 and 7x7mm

1.3 Block Diagram

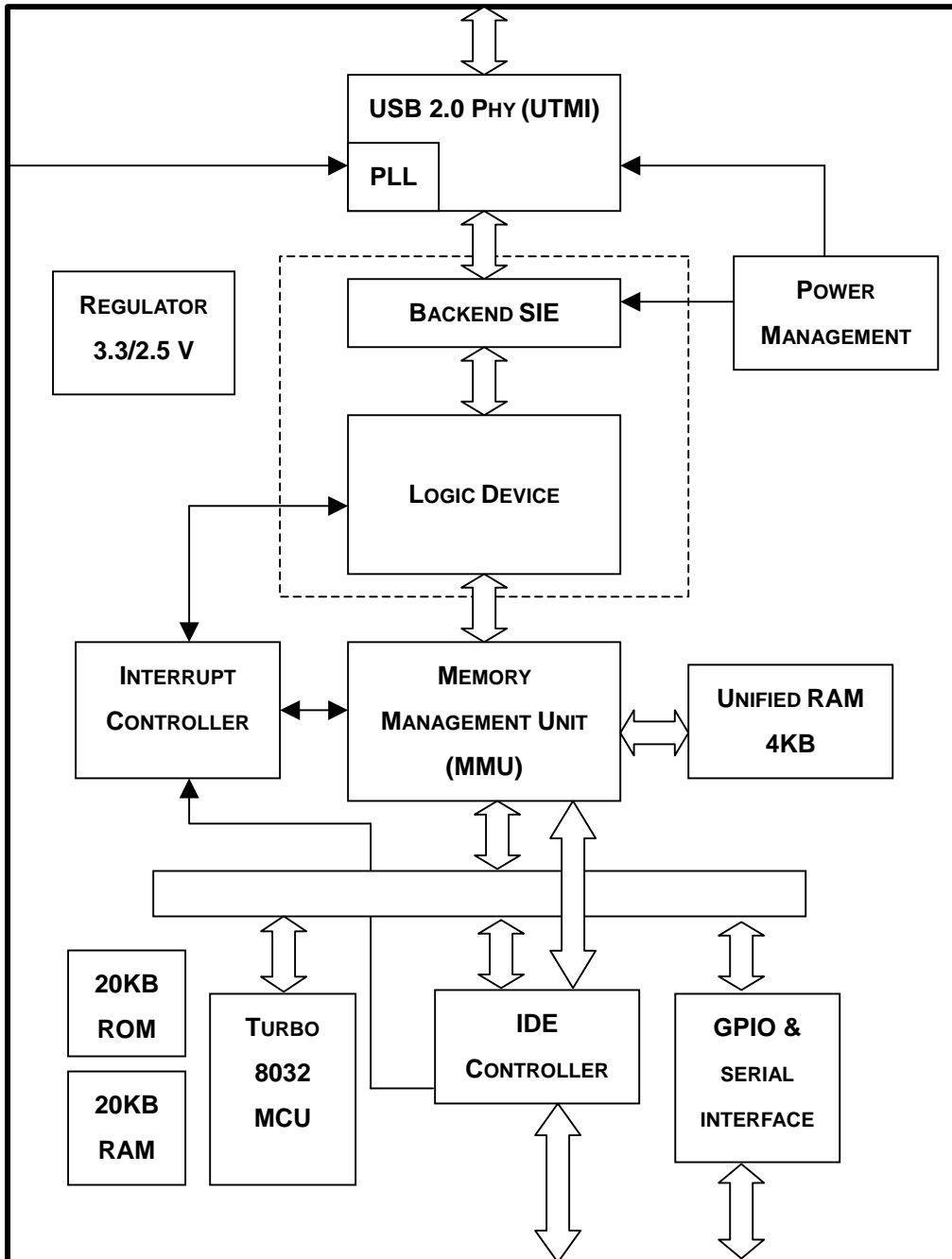

Figure 1-1 Block Diagram of PL-2507C

2.0 PIN Assignment & Description

2.1 Pin Assignment for LQFP64 Package

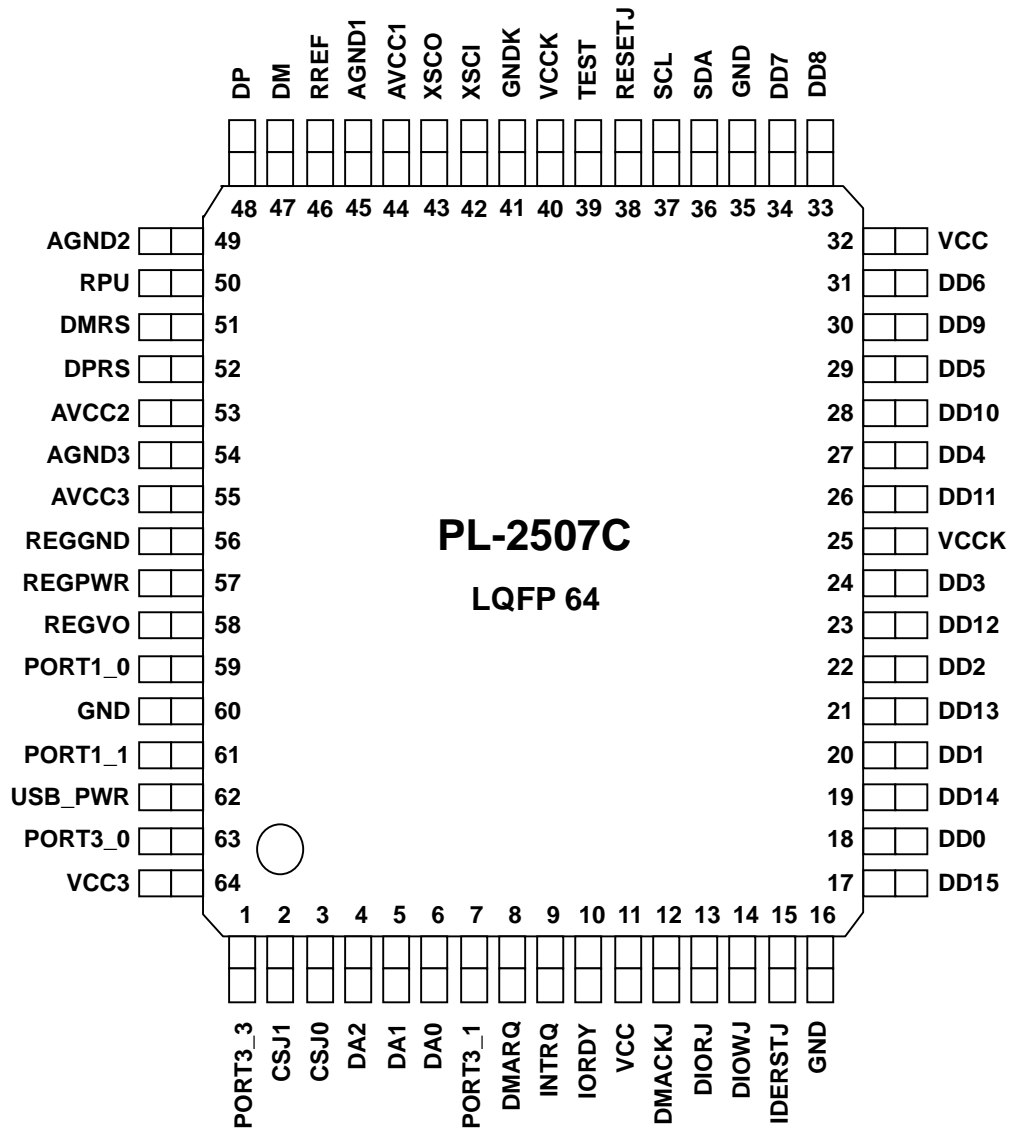

Figure 2-1 Pin Assignment Diagram of PL-2507C LQFP64

2.2 USB2.0 PHY Related Pins

Pin Type Abbreviation:

I: Input O: Output B: Bidirectional A: Analog P: Power/Ground T: Tri-state

Table 2-2 USB2.0 PHY Related Pins

Symbol	Type	Pin No	Description
XSCI	I	42	Clock in or CMOS oscillator input.
XSCO	B	43	CMOS oscillator output.
RREF	A	46	PLL Reference level
DP	B	48	High speed DPLUS signal
DM	B	47	High speed DMINUS signal
RPU	A	50	1.5 K-ohm Pull-up resistor
DPRS	B	52	Full speed DPLUS signal
DMRS	B	51	Full speed DMINUS signal
VCKK	P	40	Digital Power 2.5v
GNDK	P	41	Digital Ground
AVCC1, AVCC2, AVCC3	P	44, 53, 55	Analog Power 3.3v for on-chip PHY
AGND1, AGND2, AGND3	P	45, 49, 54	Analog Ground for on-chip USB PHY.

2.3 IDE Interface Related Pins

Table 2-3 IDE Interface Related Pins

Symbol	Type	Pin No	Description
DD[15:0]	B	17,19, 21,23, 26,28, 30,33, 34,31, 29,27, 24,22, 20,18	16 pins Data bus of IDE interface
DA[2:0]	T	4,5,6	DA, Data Address pins of IDE interface. Will be in high impedance state until USB connection.
CSJ[1:0]	T	2,3	CS_, Chip Select pins of IDE interface. Will be in high-impedance state until USB connection.
USB_PWR	I	62	USB VCC signal from USB connection.
IDERSTJ	T	15	Hardware reset pin of IDE interface. Will be in high impedance state until USB connection.

2.4 IDE Interface Related Pins

Table 2-4 IDE Interface Related Pins

Symbol	Type	Pin No	Description
DIOWJ	T	14	ATA control. Will be in high impedance state until USB connection.
DIORJ	T	13	ATA control. Will be in high impedance state until USB connection.
DMACKJ	T	12	ATA control. Will be in high impedance state until USB connection.
IORDY	I	10	ATA control.
INTRQ	I	9	ATA control.
DMARQ	I	8	ATA control.

2.5 System Pins

Table 2-5 System Pins

Symbol	Type	Pin No	Description
REGPWR	P	57	3.3v Power pin for on-chip 3.3v/2.5v regulator
REGGND	P	56	Ground pin for on-chip 3.3v/2.5v regulator
REGVO	P	58	2.5v power output of 3.3v/2.5v regulator
RESETJ	I	38	External reset pin. Low active.
SCL	O	37	Clock pin of SPI or two wire serial EEPROM or serial Flash interface
SDA	B	36	Data pin of SPI or two wire serial EEPROM or serial Flash interface
TEST	I	39	Chip Test mode enable. It shall be tie to ground for normal operation.
PORT1_0	B	59	SPI serial interface CS (chip select) signal or general purpose I/O pin.
PORT1_1	B	61	General Purpose I/O pin.
PORT3_0	B	63	USB speed LED output or general purpose I/O pin.
PORT3_1	B	7	When bus powered, control external power switch. Or general purpose I/O pin.
PORT3_3	B	1	Press button input or general purpose I/O pin.
VCC	P	11,32,64	3.3v Power pins
VCCK	P	25	2.5v Power pins
GND	P	16,35,60	Digital ground pins

3.0 USB Port Descriptor for PL-2507C

PL-2507C supports the following standard USB descriptors:

- Device descriptor.
- Configuration descriptor that supports one interface.
- String descriptors. Three string descriptors are implemented namely, language ID, Vendor String, and Product String.

3.1 Device Descriptor

Table 3-1 Device Descriptor

Offset	Field	Size	Value	Description
0	bLength	Byte	12h	Size of this descriptor in bytes.
1	bDescriptorType	Byte	01h	DEVICE descriptor type.
2	bcdUSB	Word	0200h	USB Specification version 2.0
4	bDeviceClass	Byte	00h	Interface Specific.
5	bDeviceSubclass	Byte	00h	Interface Specific.
6	bDeviceProtocol	Byte	00h	Interface Specific.
7	wMaxPacketSize0	Byte	40h	Maximum packet size for endpoint 0 is 64.
8	idVendor	Word	067Bh	Vendor ID for Prolific Technologies. ⁽¹⁾
10	idProduct	Word	2507h	Product ID for PL-2507C. ⁽¹⁾
12	bcdDevice	Word	0100h	Device Release 1.0. ⁽¹⁾
14	iManufacturer	Byte	01h	String index 1 describes manufacturer. ⁽²⁾
15	iProduct	Byte	02h	String index 2 describes product. ⁽³⁾
16	iSerialNumber	Byte	00h	No serial number string
17	bNumConfigurations	Byte	01h	One possible configuration

Notes:

⁽¹⁾ – These default values shown here could be modified by external EEPROM.

⁽²⁾ – The default string is "Prolific Technology Inc." in UNICODE format and could be replaced by the contents of external EEPROM.

⁽³⁾ – The default string is "ATAPI-6 Bridge Controller" in UNICODE format and could be replaced by the contents of external EEPROM.

3.2 Configuration Descriptor

Table 3-2 Configuration Descriptor

Offset	Field	Size	Value	Description
0	bLength	Byte	09h	Size of this descriptor in bytes.
1	bDescriptorType	Byte	02h	CONFIGURATION descriptor type.
2	bTotalLength	Word	0020h	32 bytes of all INTERFACE & ENDPOINT.
4	bNumInterfaces	Byte	01h	The PL-2507C has one interface.
5	bConfigurationValue	Byte	01h	Value to write to the Device Configuration Register (DCR) to select this configuration.
6	iConfiguration	Byte	00h	No string description for this.
7	bmAttributes	Byte	C0h	Configuration characteristics: ⁽⁴⁾ Self-Powered & No Remote Wakeup.
8	MaxPower	Byte	32h	Maximum power consumption is 100 mA. ⁽⁵⁾

Notes:

⁽⁴⁾ ⁽⁵⁾ – The default value could be replaced by the contents of external EEPROM.

3.3 Interface Descriptors

Table 3-3 Interface Descriptors

Offset	Field	Size	Value	Description
0	bLength	Byte	09h	Size of this descriptor in bytes.
1	bDescriptorType	Byte	04h	INTERFACE descriptor type.
2	bInterfaceNumber	Byte	00h	Interface 0.
3	bAlternateSetting	Byte	00h	Alternate 0.
4	bNumEndpoints	Byte	02h	Supports endpoint 0, 1, and 2.
5	bInterfaceClass	Byte	08h	MASS STORAGE class.
6	iInterfaceSubClass	Byte	06h	SCSI transparent commend set
7	bInterfaceProtocol	Byte	50h	Bulk-Only Transport protocol.
8	iInterface	Byte	00h	No String descriptor for this interface.

3.4 Endpoint Descriptors

3.4.1 In High speed mode

Table 3-4-1a Bulk Out Endpoint Descriptor (Endpoint 1)

Offset	Field	Size	Value	Description
0	bLength	Byte	07h	Size of this descriptor in bytes.
1	bDescriptorType	Byte	05h	ENDPOINT descriptor type.
2	bEndpointAddress	Byte	01h	Out Endpoint 1.
3	bmAttributes	Byte	02h	BULK Endpoint.
4	wMaxPacketSize	Word	0200h	Maximum packet size is 512.
6	bInterval	Byte	00h	N/A

Table 3-4-1b Bulk In Endpoint Descriptor (Endpoint 2)

Offset	Field	Size	Value	Description
0	bLength	Byte	07h	Size of this descriptor in bytes.
1	bDescriptorType	Byte	05h	ENDPOINT descriptor type.
2	bEndpointAddress	Byte	82h	In Endpoint 2.
3	bmAttributes	Byte	02h	BULK Endpoint
4	wMaxPacketSize	Word	0200h	Maximum packet size is 512.
6	bInterval	Byte	00h	N/A

3.4.2 In Full speed mode

Table 3-4-2a Bulk Out Endpoint Descriptor (Endpoint 1)

Offset	Field	Size	Value	Description
0	bLength	Byte	07h	Size of this descriptor in bytes.
1	bDescriptorType	Byte	05h	ENDPOINT descriptor type.
2	bEndpointAddress	Byte	01h	Out Endpoint 1.
3	bmAttributes	Byte	02h	BULK Endpoint.
4	wMaxPacketSize	Word	0040h	Maximum packet size is 64.
6	bInterval	Byte	00h	N/A

Table 3-4-1b Bulk In Endpoint Descriptor (Endpoint 2)

Offset	Field	Size	Value	Description
0	bLength	Byte	07h	Size of this descriptor in bytes.
1	bDescriptorType	Byte	05h	ENDPOINT descriptor type.
2	bEndpointAddress	Byte	82h	In Endpoint 2.
3	bmAttributes	Byte	02h	BULK Endpoint
4	wMaxPacketSize	Word	0040h	Maximum packet size is 64.
6	bInterval	Byte	00h	N/A

3.5 Device_Qualifier Descriptors

Table 3-5 Device Qualifier Descriptors

Offset	Field	Size	Value	Description
0	bLength	Byte	0Ah	Size of this descriptor in bytes.
1	bDescriptorType	Byte	06h	DEVICE Qualifier descriptor type.
2	bcdUSB	Word	0200h	USB Specification version 2.0
4	bDeviceClass	Byte	00h	Interface Specific.
5	bDeviceSubclass	Byte	00h	Interface Specific.
6	bDeviceProtocol	Byte	00h	Interface Specific.
7	wMaxPacketSize0	Byte	40h	Maximum packet size for endpoint 0 is 64.
8	bNumConfigurations	Byte	01h	Number of other-speed configurations.
9	bReserved	Byte	00h	Reserved for future use, must be zero

3.6 Other_Speed_Configuration Descriptors

Table 3-6 Other Speed Configuration Descriptors

Offset	Field	Size	Value	Description
0	bLength	Byte	09h	Size of this descriptor in bytes.
1	bDescriptorType	Byte	07h	CONFIGURATION descriptor type.
2	bTotalLength	Word	0020h	32 bytes of all INTERFACE & ENDPOINT.
4	bNumInterfaces	Byte	01h	Number of interface supported, one interface.
5	bConfigurationValue	Byte	01h	Value to write to the Device Configuration Register (DCR) to select this configuration.
6	iConfiguration	Byte	00h	No string description for this.
7	bmAttributes	Byte	C0h	Configuration characteristics: Self-Powered & No Remote Wakeup.
8	MaxPower	Byte	32h	Maximum power consumption is 100 mA

4.0 Device Control Requests

- Standard USB device request set, which perform general functions for supporting the bus and bus related functions.
- Mass Storage class request set, which is an USB class defined to implement storage device over USB protocol.
- Vendor specific requests, which are implemented to provide additional control and verification method upon the optional external serial EEPROM.

4.1 Standard Device Control Requests

- SET_FEATURE/CLEAR_FEATURE: Supports DEVICE_REMOTE_WAKEUP and ENDPOINT_STALL for all endpoints. Requests with incorrect bmRequestType or endpoint number will be stalled.
- SET_CONFIGURATION/GET_CONFIGURATION
- GET_INTERFACE/SET_INTERFACE
- SET_ADDRESS
- GET_STATUS
- GET_DESCRIPTOR

SET_DESCRIPTOR and SYNCH_FRAME are not supported by the PL-2507C.

4.2 Class Specific Requests

Table 4-2 Class Specific Requests

Command	bmType	bRequest	wValue	wIndex	wLength	Data	Note
Bulk-Only Mass Storage Reset	0x21	0xFF	0	interface	0	None	
Get Max LUN	0xA1	0xFE	0	interface	1	1 byte	

4.2.1 Bulk-Only Mass Storage Reset

This request is used to reset the mass storage device and its associated interface. This class-specific request shall ready the device for the next CBW from the host. The host shall send this request via the default pipe to the device. The device shall preserve the value of its bulk data toggle bits and endpoint STALL conditions despite the Bulk-Only Mass Storage Reset. The device shall NAK the status stage of the device request until the Bulk-Only Mass Storage Reset is complete.

4.2.2 Get Max LUN

The device may implement several logical units that share common device characteristics. The host uses bCBWLUN (see 5.1 Command Block Wrapper (CBW)) to designate which logical unit of the device is the destination of the CBW. The Get Max LUN device request is used to determine the number of logical units supported by the device. Logical Unit Numbers on the device shall be numbered contiguously starting from LUN 0 to a maximum LUN of 15 (Fh).

4.3 Vendor Specific Requests

Table 4-3 Vendor Specific Requests

Command	bmType	bRequest	wValue	wIndex	wLength	Data	Note
SET_EEPROM_STR	0x41	0x05	0	0	BL	Data String	
GET_EEPROM_STR	0xC1	0x06	0	0	BL	Data String	

Note: The BL shall not exceed 255, the requests will be stalled otherwise.

4.3.1 SET_EEPROM_STRING Request

The PL-2507C supports the option to store the Vendor ID, Product ID, and Device Release Number in device descriptor, Attributes and Max Power setting in configuration descriptor, and Strings of String Descriptor in an external Serial EEPROM. The PL-2507C will detect the existence of the EEPROM automatically after reset. If the first word retrieved from the EEPROM matches the predefined check byte, 0x067B, it would use the data from this external EEPROM instead of the data from internal ROM.

The vendor specific SET_EEPROM_STRING request is used to change the contents of the EEPROM. The data part of this request is written to the EEPROM from address 0 all the way up to address 255. Therefore, it is necessary for the software to prepare the whole table first and then write it to the EEPROM in one single SET_EEPROM_STRING request.

4.3.2 GET_EEPROM_STRING Request

This request allows driver on host side retrieve the whole data table resides in the external serial EEPROM. The returned data is retrieved starting from address 0 to the end of data table from EEPROM. It is mostly used as a verification method to check the data integrity of the previous write.

5.0 External Serial Memory

5.1 External Serial Memory

The PL-2507C uses external serial memory (EEPROM or Flash) to store the Vendor ID, Product ID, Device Release Number in device descriptor, Attributes and Max Power setting in configuration descriptor, Strings of String Descriptor and some chip operation mode configuration. A new version firmware can be stored in this memory when this memory size is large enough. If the external serial memory is not present, PL-2507C will use settings in the internal ROM. Two types of serial interface are supported, the one is SPI (Serial Peripheral Interface) and the other is I2C compatible interface.

The PL-2507C can be used as below:

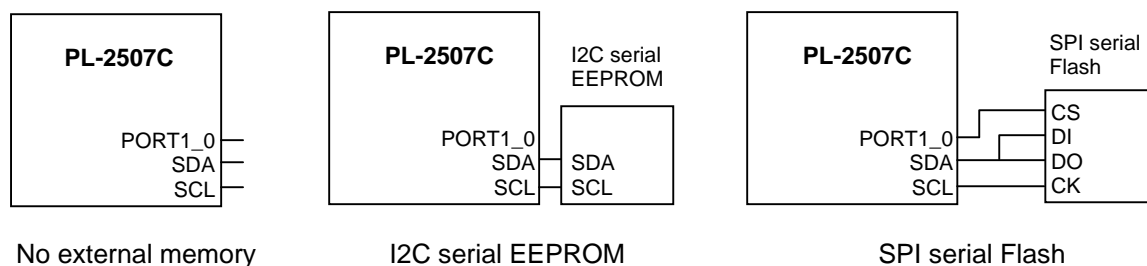

Figure 5-1 External Serial Memory Implementation

- **No external memory:** This case is not recommended. The chip will use the default configuration in the internal ROM and run the firmware in the internal ROM. Firmware upgrade is not possible. The chip will send default Vendor ID, Product ID, chip operation settings, and other default configuration. Product serial number will not be sent.
- **I2C serial EEPROM:** This case uses I2C serial EEPROM to store chip configuration data or configuration data with new firmware. If the I2C serial EEPROM size (like 24C256) is large enough, a new version firmware can be stored therefore new firmware upgrade is possible. If new version firmware is stored in the EEPROM, new firmware will be loaded while system startup.
- **SPI serial Flash:** This is the recommended case. It behaves the same as the I2C serial memory with this chip. But the transfer speed of SPI interface is faster than I2C interface. The device like 25C256 is suitable. The SPI interface is a four-pin interface but this chip uses only three pins to communicate with. Therefore, the DI and DO are shorted or short by a serial 240-ohm resistor is better.

5.2 Data Structure of External Serial Memory Content

The EEPROM is organized as following:

Table 5-2a EEPROM Address and Content

Address	Content	Note
1:0	Check Word – 0x067B (Predefined constant)	
3:2	Vendor ID (idVendor field of Device Descriptor)	
5:4	Product ID (idProduct field of Device Descriptor)	
7:6	Device Release Number (bcdDevice field of Device Descriptor)	
8	Attributes (bmAttributes field of Configuration Descriptor)	
9	Max Power (MaxPower field of Configuration Descriptor)	
10	Chip operation settings	
14:11	External firmware control	
15	IDE transfer mode control	
255:16	String Descriptor Table	
-:256	External firmware	

From byte 16 to byte 230 are used for USB string descriptors. The String Descriptor table is a linked data structure that holds all string descriptors recognized by this chip in the order of its index. The first entry, String 0, represents the Language ID, as defined by the USB specification. The second entry, String 1, is the Manufacturer Descriptor, as defined by the Device Descriptor of PL-2507C. The third and fourth entries, String 2 and 3, are the Product Descriptor and Serial Number, respectively, also defined by the Device Descriptor. The user has the option to define String 4, 5, and 6 for their own private use. Each of these String Descriptor Entries is of the following data structure:

Table 5-2b String Descriptor Data Structure

Offset	Field	Size	Value	Note
0	bLength	1	Length of the string plus 2, i.e. (N + 2).	
1	bDescriptorType	1	03h – STRING Descriptor type.	
2	bString	N	UNICODE encoded string.	

The last entry of this table must have a bLength of 0 to indicate the end of this table. If the host tries to access to the string descriptor beyond the last one, a zero-length data will be returned. The following table shows one example of valid EEPROM contents.

Table 5-2c Example of Valid EEPROM Contents

Offset	Content	Note
0:1	Check Word – 0x067B	Constant
2:3	Vendor ID – 0x067B	
4:5	Product ID – 0x2507	
6:7	Device Release Number – 0x0100	
8		
9		
15:10		
16	0x04	String Index 0 (4 Bytes)
17	0x03	
19:18	0x0409	Language ID for English (United States).
20	0x32	String Index 1 (50 Bytes)
21	0x03	
69:22	'P', 0x00, 'r', 0x00, 'o', 0x00, 'l', 0x00, 'i', 0x00, 'f', 0x00, 'i', 0x00, 'c', 0x00, ' ', 0x00, 'T', 0x00, 'e', 0x00, 'c', 0x00, 'h', 0x00, 'n', 0x00, 'o', 0x00, 'l', 0x00, 'o', 0x00, 'g', 0x00, 'y', 0x00, ' ', 0x00, 'l', 0x00, 'n', 0x00, 'c', 0x00, ' ', 0x00	"Prolific Technology Inc." – manufacturer description. 0x00 is padded for UNICODE.
70	0x34	String Index 2 (52 Bytes)
71	0x03	
121:72	'A', 0x00, 'T', 0x00, 'A', 0x00, 'P', 0x00, 'l', 0x00, '-', 0x00, '6', 0x00, ' ', 0x00, 'B', 0x00, 'r', 0x00, 'i', 0x00, 'd', 0x00, 'g', 0x00, 'e', 0x00, ' ', 0x00, 'C', 0x00, 'o', 0x00, 'n', 0x00, 't', 0x00, 'r', 0x00, 'o', 0x00, 'l', 0x00, 'l', 0x00, 'e', 0x00, 'r', 0x00	"ATAPI-6 Bridge Controller" – device description. 0x00 is padded for UNICODE.
122	0x0A	String Index 3 (10 bytes)
123	0x03	
131:124	'0', 0x00, '1', 0x00, '2', 0x00, '3', 0x00	"3210" – serial number,
132	0x00	End of String Descriptor Table.

The user could also define other strings, 4 to 6, to hold useful information for the drivers and/or applications, such as software authorization codes, symbolic names, just to name a few. However, the total length of this table must not exceed 256 bytes, the supported maximum size of external EEPROM.

6.0 DC Characteristics

6.1 Absolute Maximum Ratings

Table 6-1 Absolute Maximum Ratings

SYMBOL	PARAMETER	RATING	UNITS
V _{CC}	2.5V Power Supply	-0.3 to 3.0	V
	3.3V Power Supply	-0.3 to 3.9	
V _{IN3}	Input Voltage of 3.3V I/O	-0.3 to V _{CC3I} +0.3	V
	Input Voltage of 3.3V I/O with 5V Tolerance	-0.3 to 5.5	
T _{STG}	Storage Temperature	-40 to 150	°C

6.2 Operating Current Parameters

Table 6-2 Operating Current Parameters

SYMBOL	PARAMETER	TYP	UNITS
I _{DD}	High Speed V _{DD} Supply Current	100	mA
I _{SUS}	Suspend Current	< 2.5	mA

6.3 Recommended Operating Conditions

Table 6-3 Recommended Operating Conditions

SYMBOL	PARAMETER	MIN	TYP	MAX	UNITS
V _{CCK}	Power Supply of 2.5V I/O	2.25	2.5	2.75	V
V _{CC}	Power Supply of 3.3V I/O	3.0	3.3	3.6	V
T _J	Junction Operating Temperature	0	25	115	°C

6.4 Leakage Current and Capacitance⁽³⁾

Table 6-4 Leakage Current and Capacitance

SYMBOL	PARAMETER	CONDITIONS	MIN	TYP	MAX	UNITS
I _{IL}	Input Leakage Current ⁽²⁾	No pull-up or pull-down	-10		10	μA
C _{IN2}	Input Capacitance			3.1		pF
C _{OUT2}	Output Capacitance			3.1		pF

Notes:

- (1) Permanent device damage may occur if Absolute Maximum Ratings are exceeded.
- (2) The pull up/pull down input leakage current can be derived from the pull up/pull down resistance (R_{pu}/R_{pd}) in the DC characteristics table for each type I/O buffer.
- (3) The capacitances listed above do not include PAD capacitance and package capacitance. One can estimate pin capacitance by adding pad capacitance's that is about 0.1pF and the package capacitance.

6.5 DC Characteristics of 3.3V Programmable I/O Cells

Table 6-5 DC Characteristics of 3.3V Programmable I/O Cells

SYMBOL	PARAMETER	CONDITIONS	MIN	TYP	MAX	UNITS
V _{CC31}	Power Supply	3.3V I/O	3.0	3.3	3.6	V
V _{IL}	Input Low Voltage*	CMOS/LVTTL			0.8	V
V _{IH}	Input High Voltage*	CMOS/LVTTL	2.0			V
I _{IN}	Input Leakage Current	V _{in} =0 or V _{CC31}	-10		10	μA

7.0 Ordering Information

Table 7-1 Ordering Information

Part Number	Package Type
PL-2507C	64-pin LQFP (10x10mm)
PL-2507C	64-pin LQFP (7x7mm)
PL-2507C LF	64-pin LQFP (10x10mm) Lead (Pb) Free
PL-2507C LF	64-pin LQFP (7x7mm) Lead (Pb) Free

8.0 Outline Diagram

8.1 LQFP64 Package (10x10) Outline Diagram

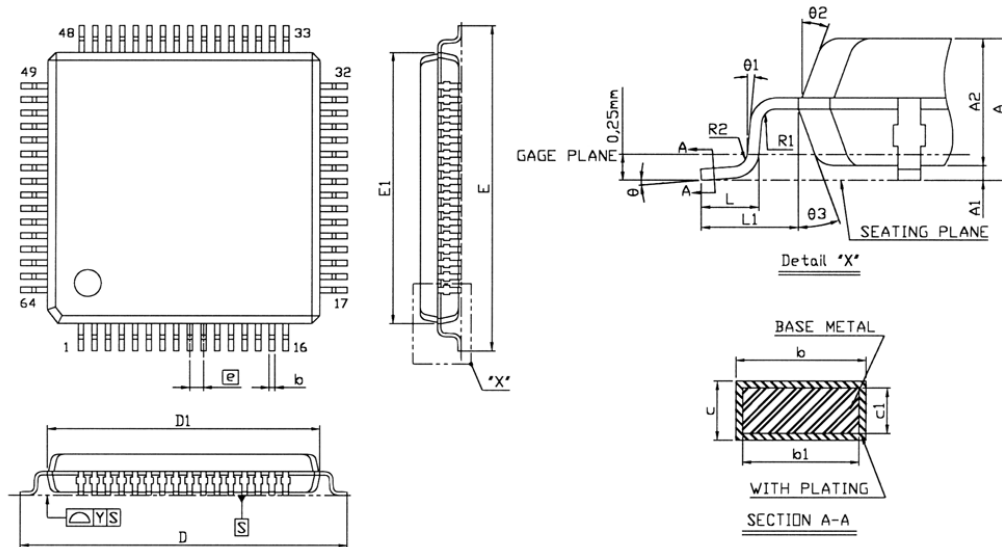

SYMBOL	DIMENSION (MM)			DIMENSION (MIL)		
	MIN.	NOM.	MAX.	MIN.	NOM.	MAX.
A			1,60			63
A1	0,05		0,15	2		6
A2	1,35	1,40	1,45	53	55	57
b	0,17	0,22	0,27	7	9	11
b1	0,17	0,20	0,23	7	8	12
c	0,09		0,20	4		8
c1	0,09		0,16	4		6
D	12,00 BSC			472 BSC		
D1	10,00 BSC			394 BSC		
E	12,00 BSC			472 BSC		
E1	10,00 BSC			394 BSC		
ⓐ	0,50 BSC			20 BSC		
L	0,45	0,60	0,75	18	24	30
L1	1,00 REF			39 REF		
R1	0,08			3		
R2	0,08		0,20	3		8
Y			0,075			3
θ	0°	3,5°	7°	0°	3,5°	7°
θ1	0°			0°		
θ2	11°	12°	13°	11°	12°	13°
θ3	11°	12°	13°	11°	12°	13°

NOTES:

- REFER TO JEDEC MS-026/BCD
- DIMENSION D1 AND E1 DO NOT INCLUDE MOLD PROTRUSION. ALLOWABLE PROTRUSION IS 0.25mm PER SIDE D1 AND E1 ARE MAXIMUM PLASTIC BODY SIZE DIMENSION INCLUDING MOLD MISMATCH.
- DIMENSION b DOES NOT INCLUDE DAMBAR PROTRUSION. ALLOWABLE DAMBAR PROTRUSION SHALL NOT CAUSE THE LEAD WIDTH TO EXCEED THE MAXIMUM b DIMENSION BY MORE THAN 0.08mm.
- ALL DIMENSIONS IN MILLIMETERS.

Figure 8-1 Outline Diagram of PL-2507C LQFP64 (10x10mm)

8.2 LQFP64 Package (7x7) Outline Diagram

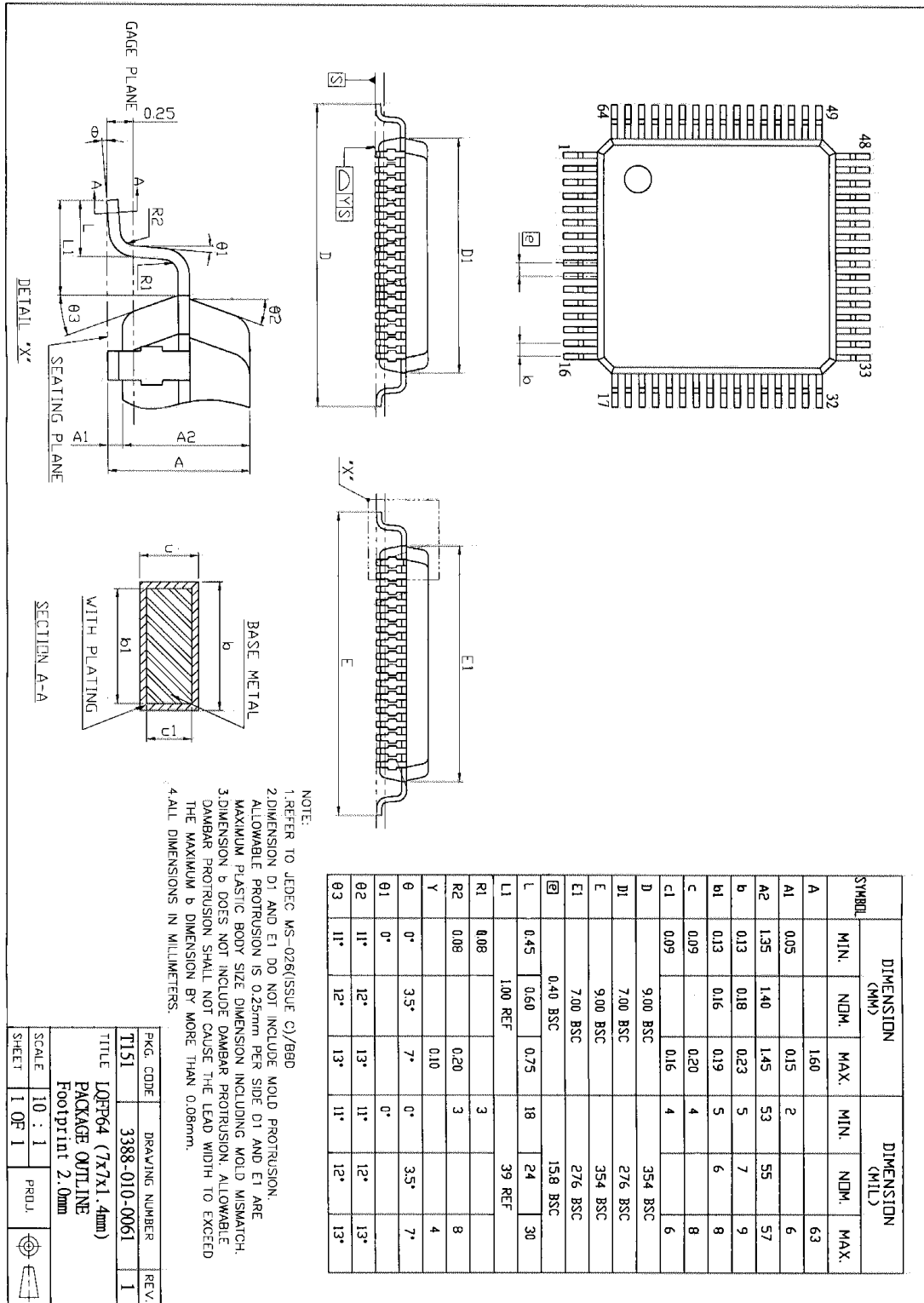

Figure 8-2 Outline Diagram of PL-2507C LQFP64 (7x7mm)