

# BV1 Block Diagram

SIT

REV : 3A

2005-05-12

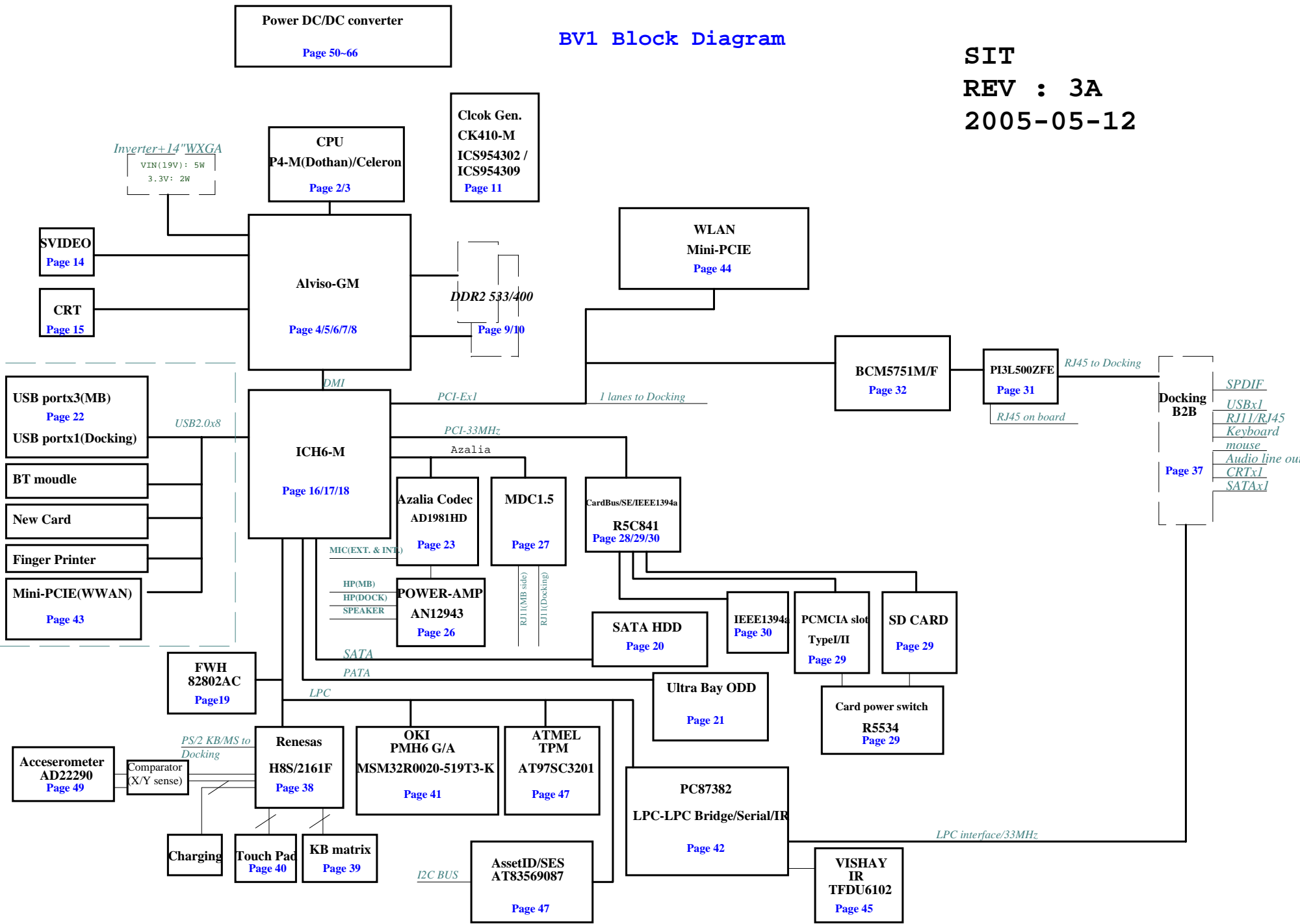

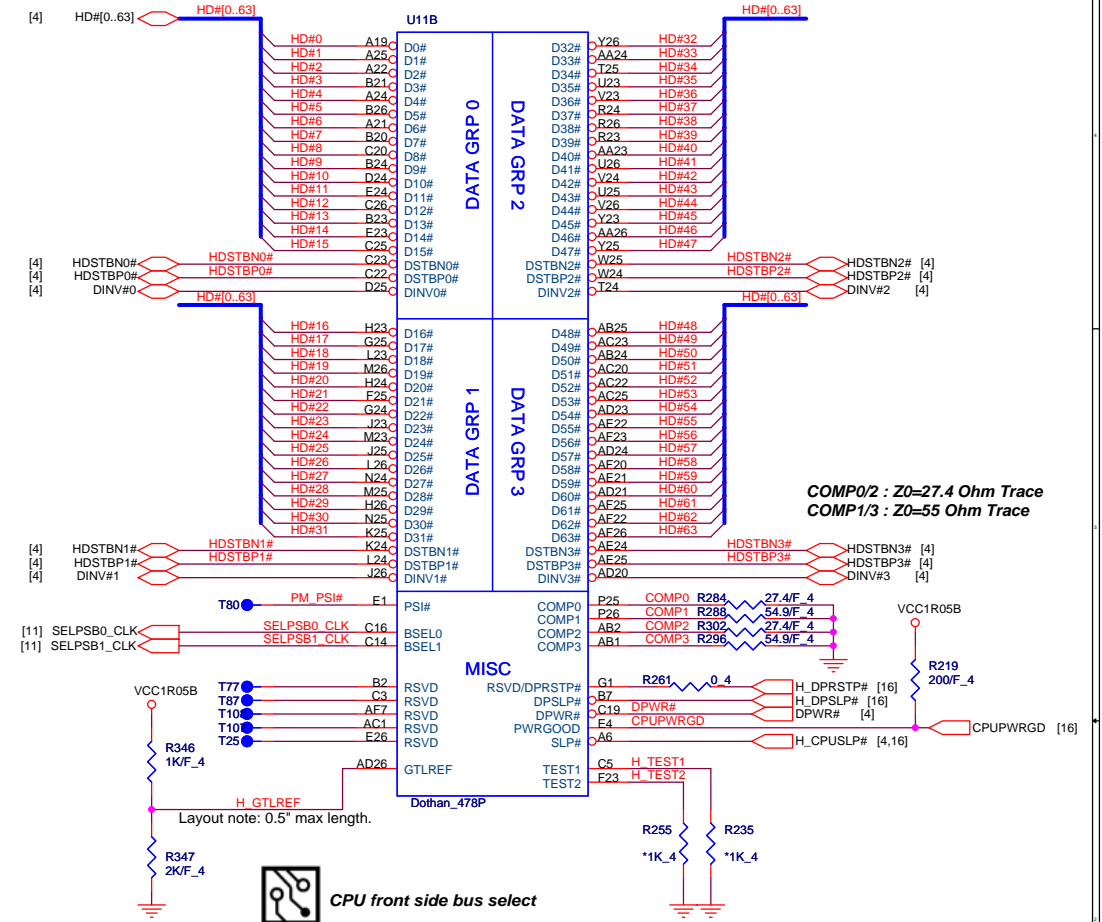
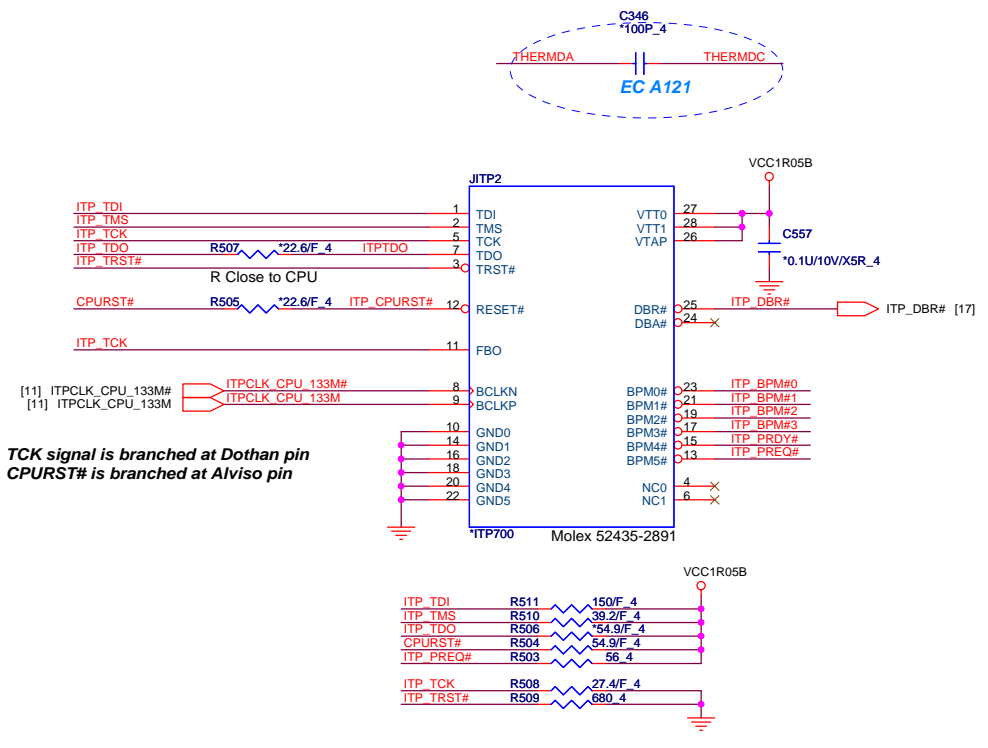
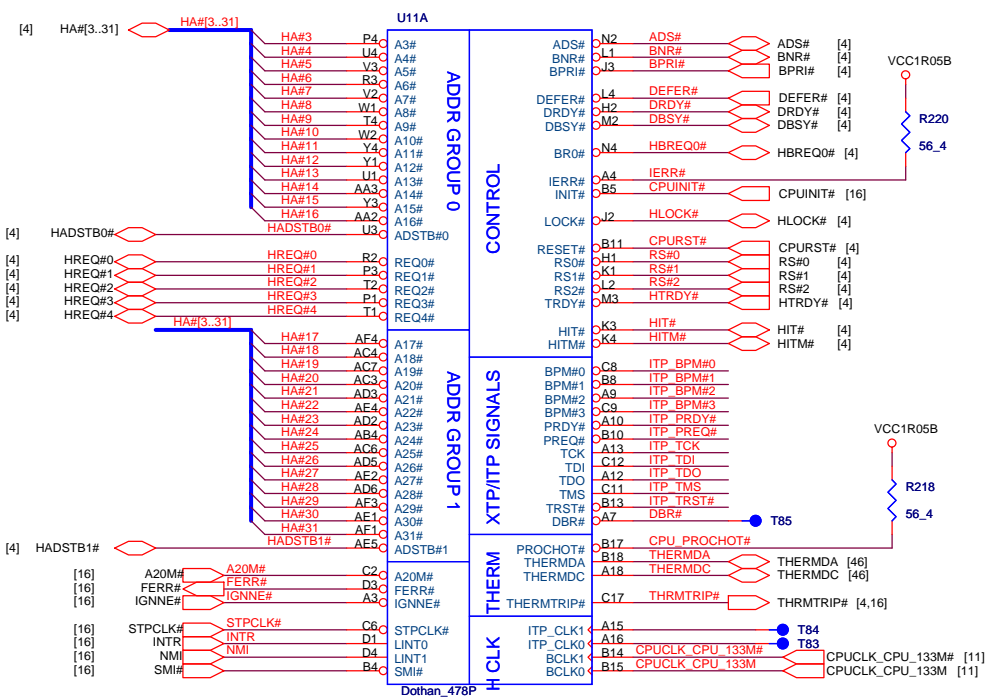

**CPU front side bus select**

	A Step	B Step
FSB	533	400
BSEL1	0	0
BSEL0	1	0

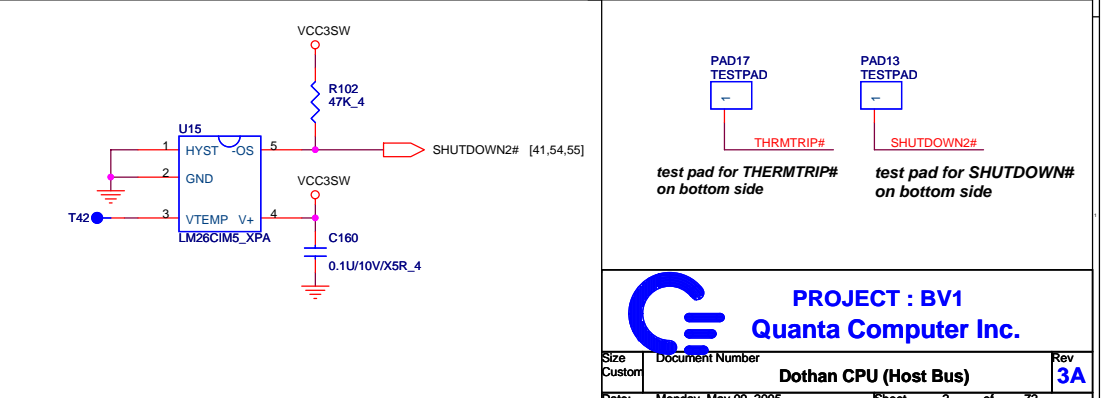

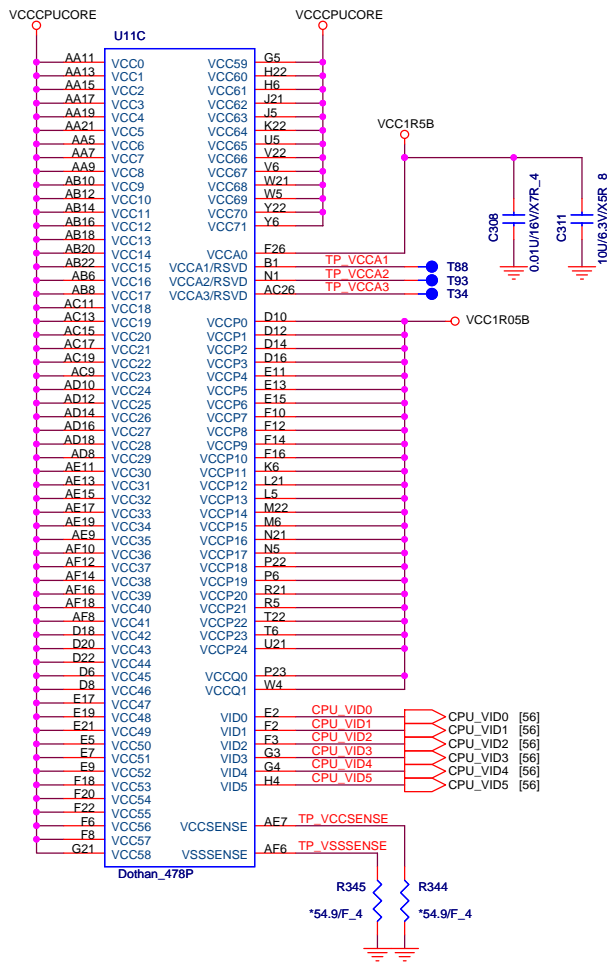

**VCCP decoupling**

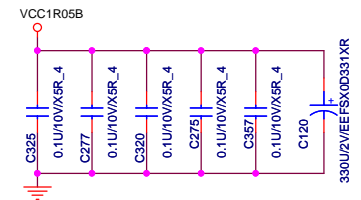
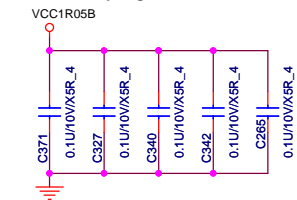

**CPU\_CORE decoupling**

10uF X5R 2012 1/16W \* 25pcs

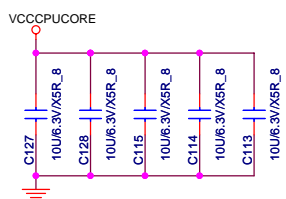
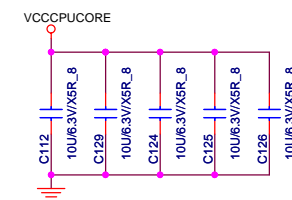
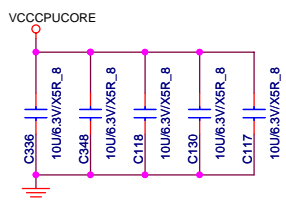
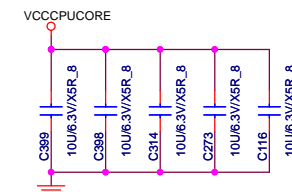
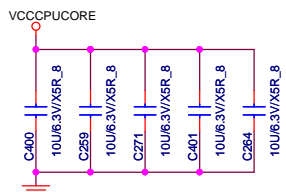

**VCCCOREPAD**

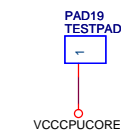

**GNDPAD**

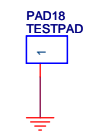

U11C		U11C	
A2	VSS0	VSS97	D13
A5	VSS1	VSS98	D15
A8	VSS2	VSS99	D17
A11	VSS3	VSS100	D19
A14	VSS4	VSS101	D21
A17	VSS5	VSS102	D23
A20	VSS6	VSS103	D26
A23	VSS7	VSS104	E3
A26	VSS8	VSS105	E6
AA1	VSS9	VSS106	E8
AA4	VSS10	VSS107	F10
AA6	VSS11	VSS108	F12
AA8	VSS12	VSS109	F14
AA10	VSS13	VSS110	F16
AA12	VSS14	VSS111	E18
AA14	VSS15	VSS112	E20
AA16	VSS16	VSS113	E22
AA18	VSS17	VSS114	E25
AA20	VSS18	VSS115	F1
AA22	VSS19	VSS116	F4
AA25	VSS20	VSS117	F5
AB3	VSS21	VSS118	F7
AB5	VSS22	VSS119	F9
AB7	VSS23	VSS120	F11
AB9	VSS24	VSS121	F13
AB11	VSS25	VSS122	F15
AB13	VSS26	VSS123	F17
AB15	VSS27	VSS124	F19
AB17	VSS28	VSS125	F21
AB19	VSS29	VSS126	F24
AB21	VSS30	VSS127	G2
AB23	VSS31	VSS128	G6
AB26	VSS32	VSS129	G22
AC2	VSS33	VSS130	G23
AC5	VSS34	VSS131	G26
AC8	VSS35	VSS132	H3
AC10	VSS36	VSS133	H5
AC12	VSS37	VSS134	H21
AC14	VSS38	VSS135	H25
AC16	VSS39	VSS136	J1
AC18	VSS40	VSS137	J4
AC21	VSS41	VSS138	J6
AC24	VSS42	VSS139	J22
AD1	VSS43	VSS140	J24
AD4	VSS44	VSS141	K2
AD7	VSS45	VSS142	K5
AD9	VSS46	VSS143	K21
AD11	VSS47	VSS144	K23
AD13	VSS48	VSS145	K26
AD15	VSS49	VSS146	L3
AD17	VSS50	VSS147	L6
AD19	VSS51	VSS148	L22
AD22	VSS52	VSS149	L25
AD25	VSS53	VSS150	M1
AE3	VSS54	VSS151	M4
AE6	VSS55	VSS152	M5
AE8	VSS56	VSS153	M21
AE10	VSS57	VSS154	M24
AE12	VSS58	VSS155	N3
AE14	VSS59	VSS156	N6
AE16	VSS60	VSS157	N22
AE18	VSS61	VSS158	N23
AE20	VSS62	VSS159	N26
AE23	VSS63	VSS160	P2
AE26	VSS64	VSS161	P5
AF2	VSS65	VSS162	P21
AF5	VSS66	VSS163	P24
AF9	VSS67	VSS164	R1
AF11	VSS68	VSS165	R4
AF13	VSS69	VSS166	R6
AF15	VSS70	VSS167	R22
AF17	VSS71	VSS168	R25
AF19	VSS72	VSS169	T3
AF21	VSS73	VSS170	T5
AF24	VSS74	VSS171	T21
B3	VSS75	VSS172	T23
B6	VSS76	VSS173	T26
B9	VSS77	VSS174	U2
B12	VSS78	VSS175	U6
B16	VSS79	VSS176	U22
B19	VSS80	VSS177	U24
B22	VSS81	VSS178	V1
B25	VSS82	VSS179	V4
C1	VSS83	VSS180	V5
C4	VSS84	VSS181	V21
C7	VSS85	VSS182	V25
C10	VSS86	VSS183	W3
C13	VSS87	VSS184	W6
C15	VSS88	VSS185	W22
C18	VSS89	VSS186	W23
C21	VSS90	VSS187	W26
C24	VSS91	VSS188	Y2
D2	VSS92	VSS189	Y5
D5	VSS93	VSS190	Y21
D7	VSS94	VSS191	Y24
D9	VSS95		
D11	VSS96		

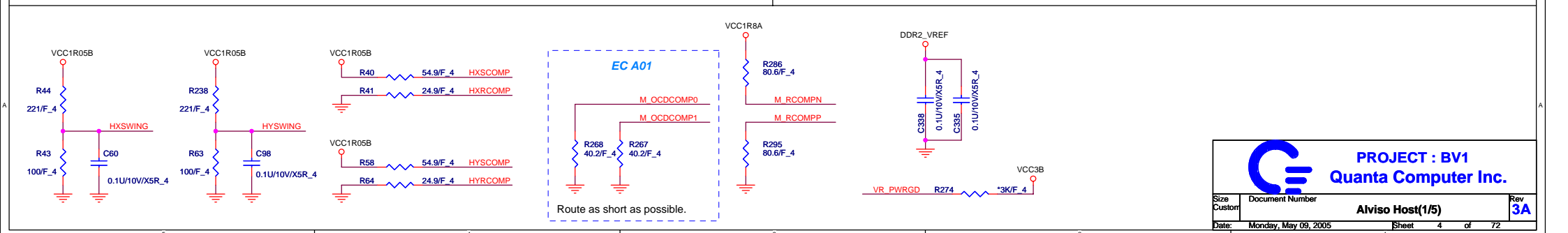
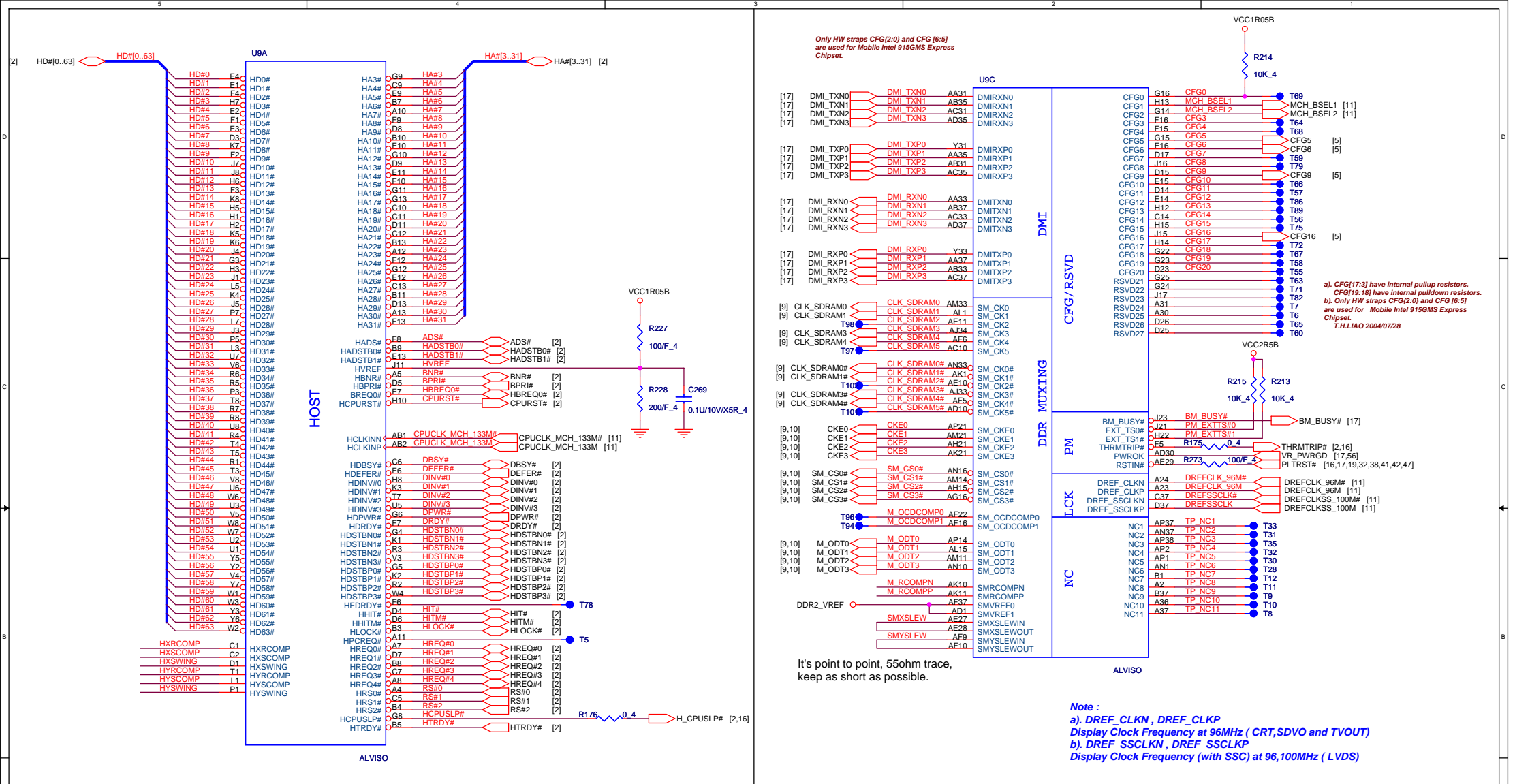

**PROJECT : BV1**  
**Quanta Computer Inc.**

Size: Document Number  
Customer: **Alviso Host(1/5)** Rev: **3A**

Date: Monday, May 09, 2005 Sheet 4 of 72

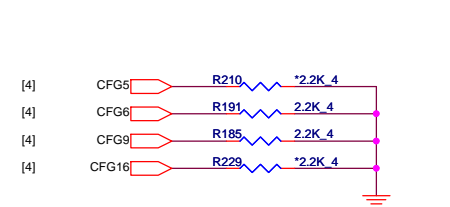
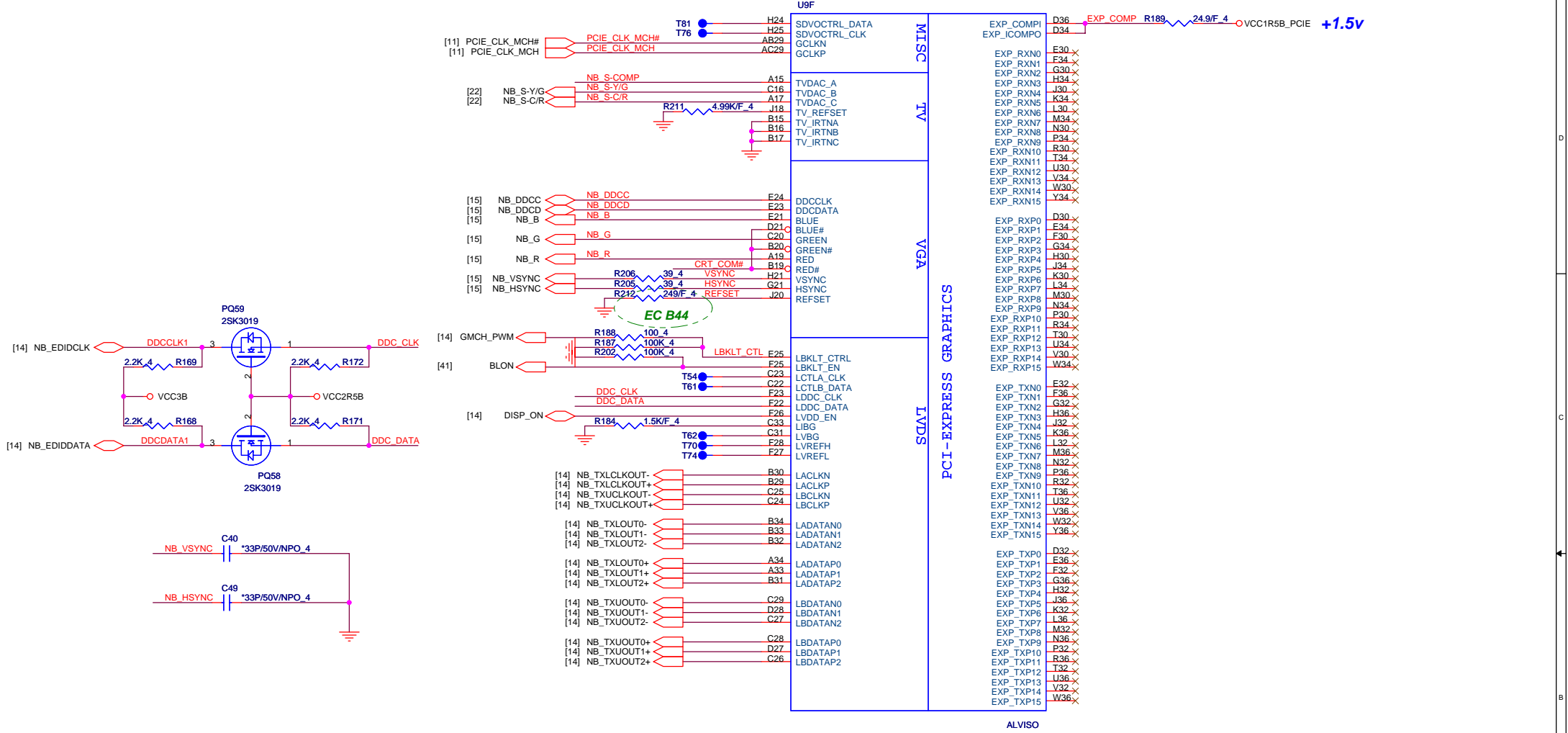

	Low	NO_ASM
CFG3	DDR533	
CFG5	DMix2	<b>DMix4</b>
CFG6	<b>DDR II</b>	DDR
CFG7	DT CPU	<b>Mobile CPU</b>
CFG9	<b>Reverse Lane</b>	Normal Operation
CFG11	FSB533	
CFG12	00 : Reserved	
CFG13	01 : XOR Mode Enabled	
	10 : All Z Mode Enabled	
	11 : <b>Normal Operation</b>	
CFG16	FSB Dynamic ODT Disabled	<b>FSB Dynamic ODT Enabled</b>

	NO_ASM	High
CFG3	<b>CPUCORE=1.05V</b>	CPUCORE=1.5V
CFG5	<b>VTT=1.05V</b>	VTT=1.2V

CFG9 : PCI-E Graphics Lane  
 Note : If in integrated GFX mode, need to use lane-reversal ADD2 add-in card since SDVO if does not support lane reversal.

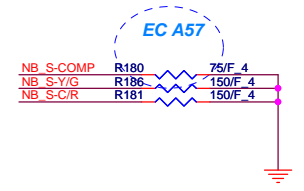
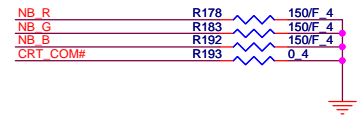



**PROJECT : BV1**  
**Quanta Computer Inc.**

Size	Document Number	Sheet	5	Rev	3A
Custom	<b>Alviso VGA/DMI (2/5)</b>				
Date:	Tuesday, May 10, 2005				

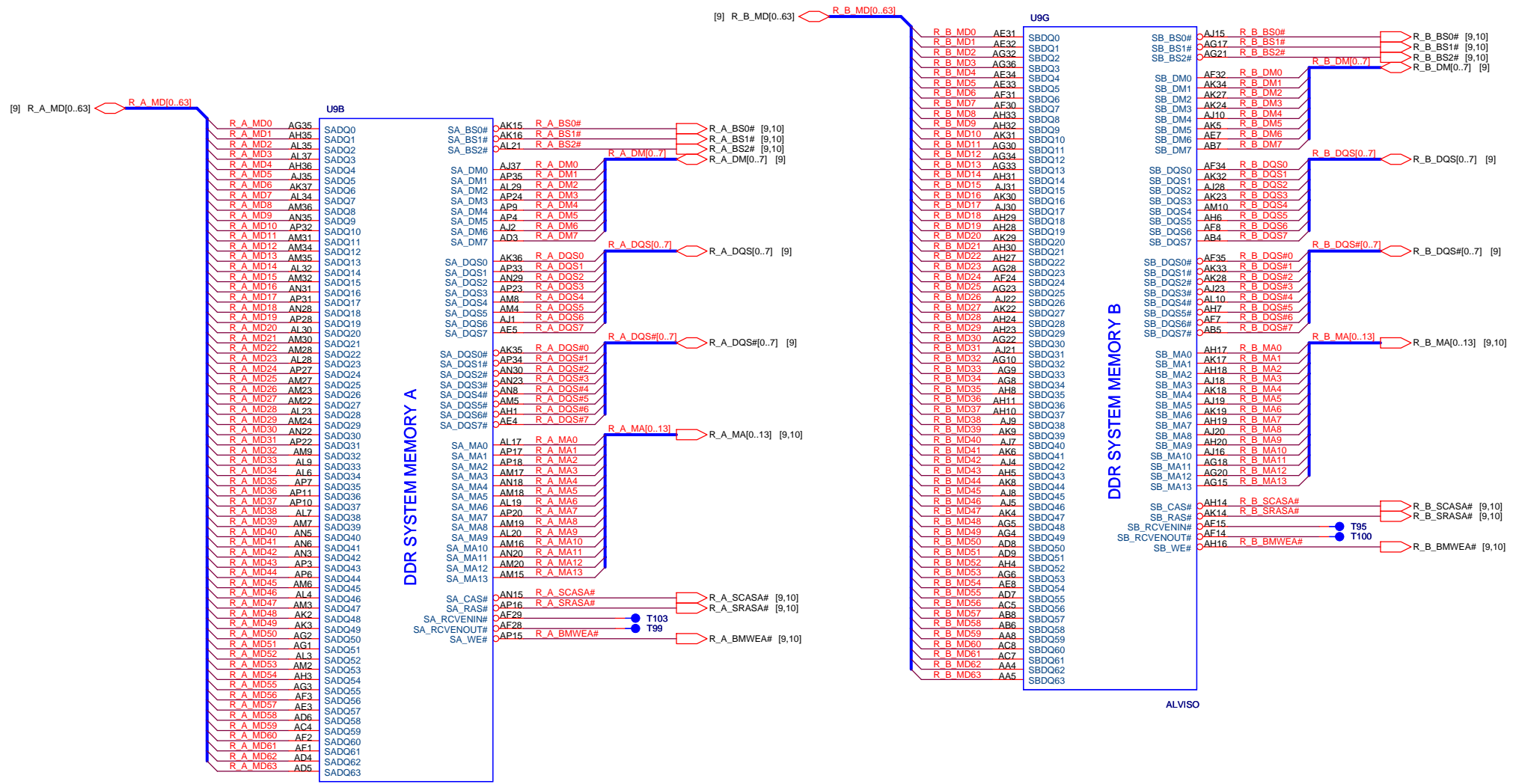





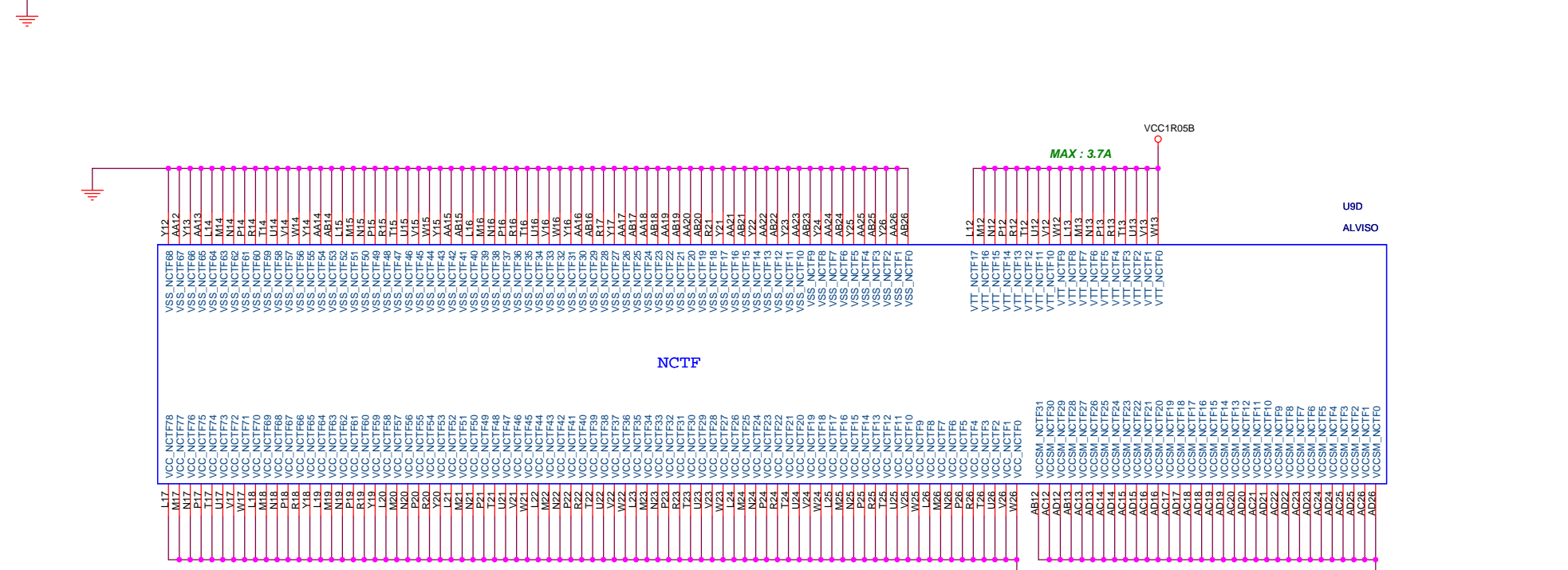
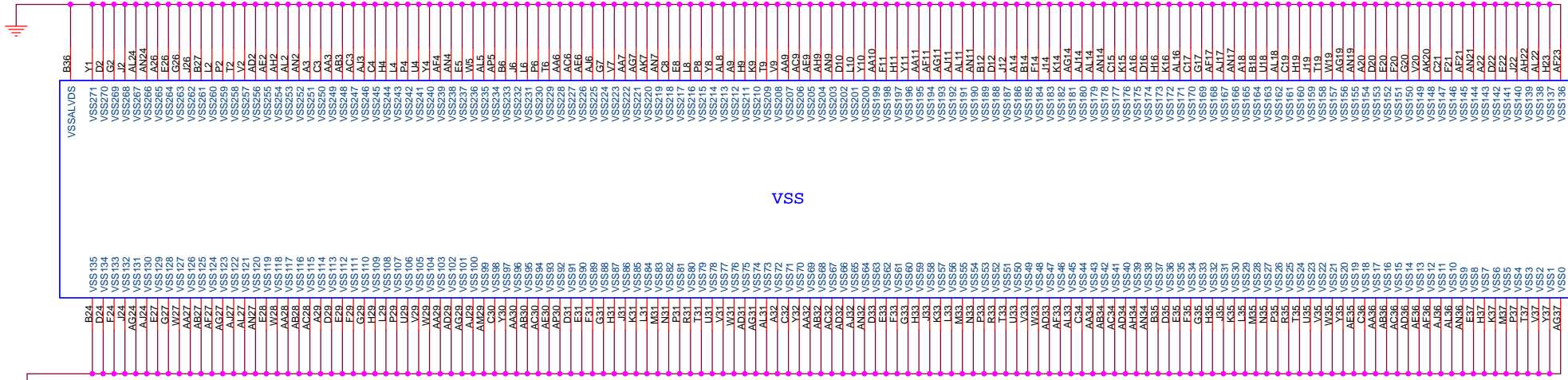

**PROJECT : BV1**  
**Quanta Computer Inc.**

Size Custom	Document Number <b>VSS/NCTF(5/5)</b>	Rev <b>3A</b>
Date: Monday, May 09, 2006	Sheet 8	of 72



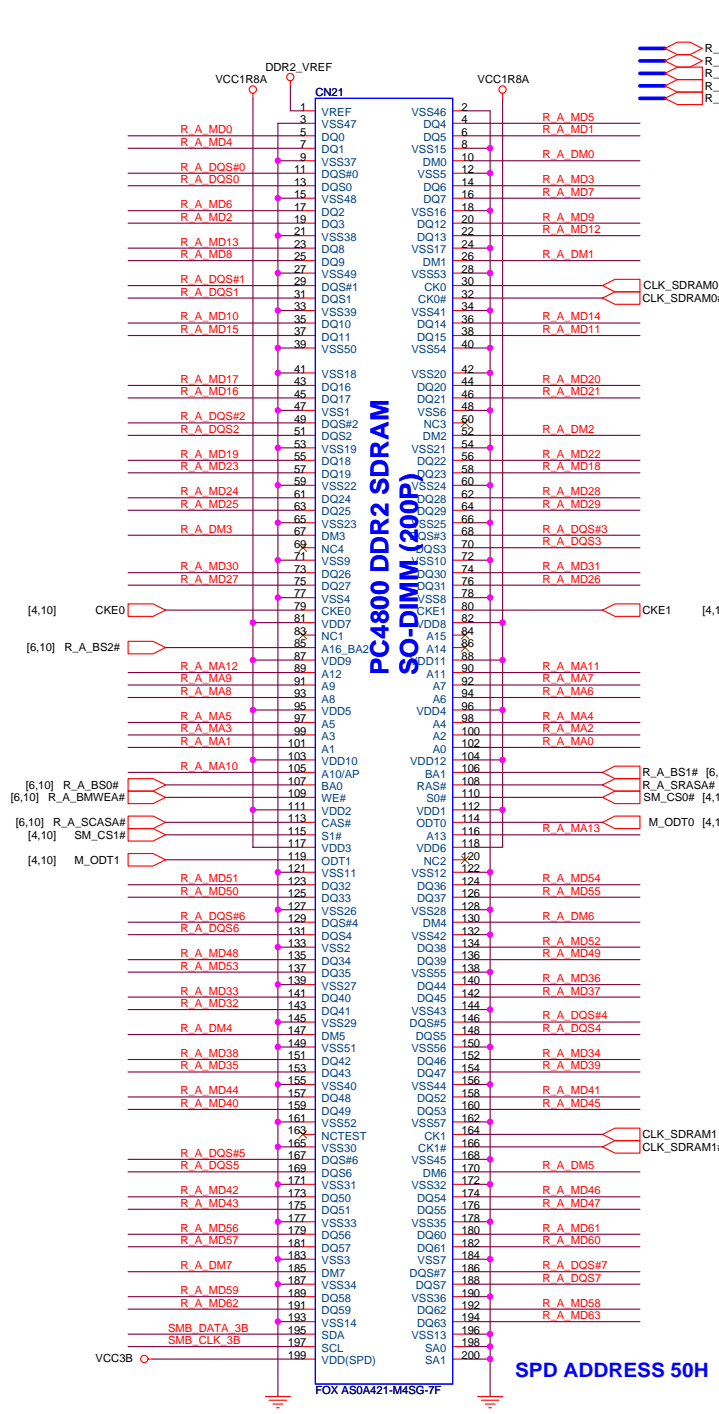

**PC4800 DDR2 SDRAM  
SO-DIMM (200P)**

**CLOCK 0,1  
CKE 0,1**

**SPD ADDRESS 50H**

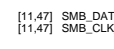
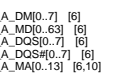

**CLOCK 3,4  
CKE 2,3**

**SPD ADDRESS 51H**

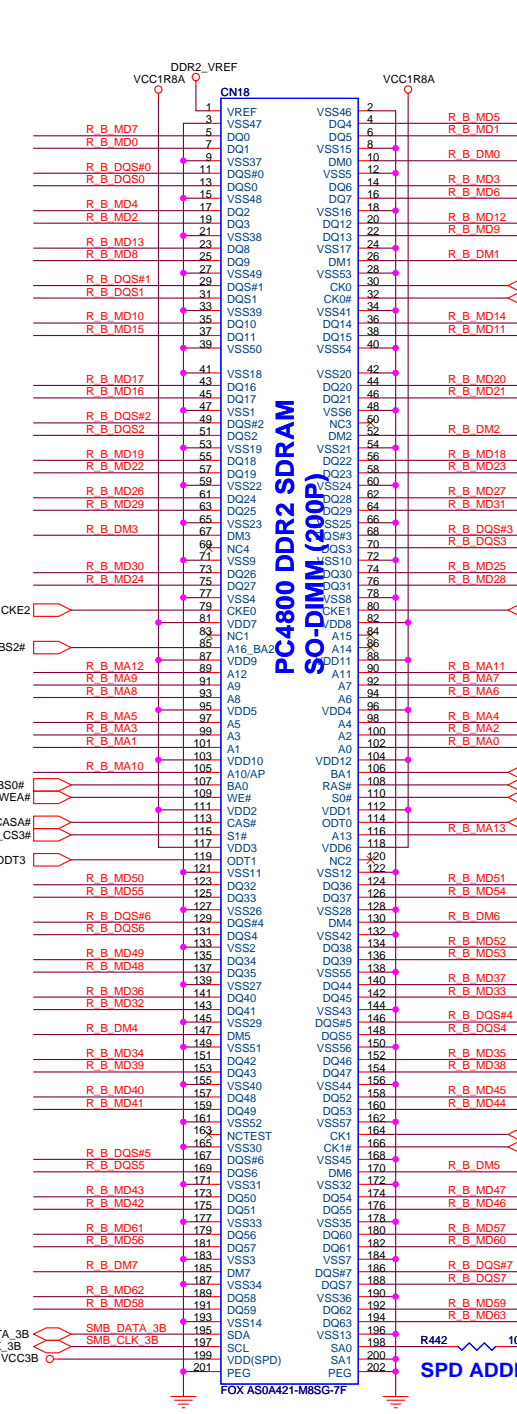

**PC4800 DDR2 SDRAM  
SO-DIMM (200P)**

**CLOCK 3,4  
CKE 2,3**

**SPD ADDRESS 51H**

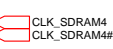
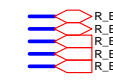

**CLOCK 3,4  
CKE 2,3**

**SPD ADDRESS 51H**

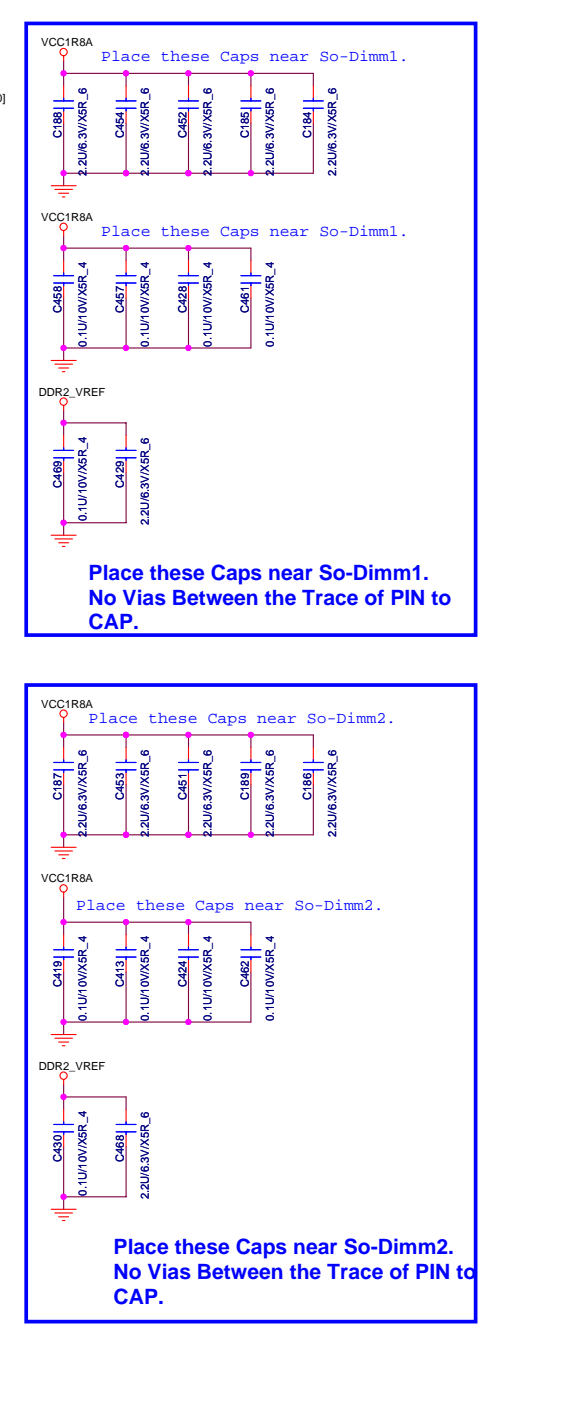

**PROJECT : BV1**  
**Quanta Computer Inc.**

# DDRII DUAL CHANNEL A,B.

## DDRII A CHANNEL

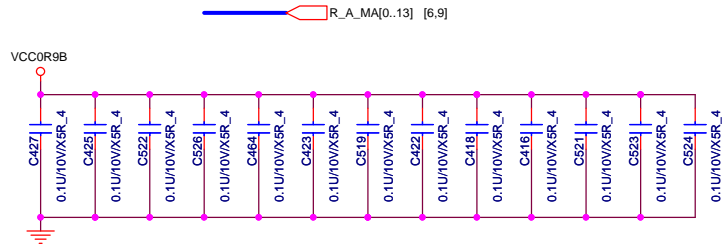

## DDRII B CHANNEL

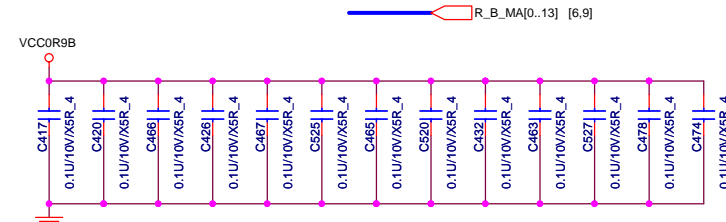

Layout note: Place one cap close to every 2 pullup resistors terminated to SMDDR\_VTERM

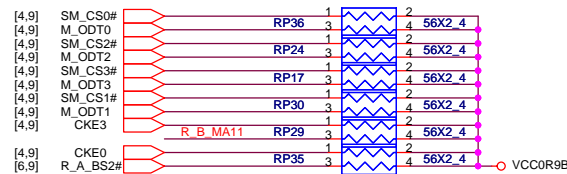
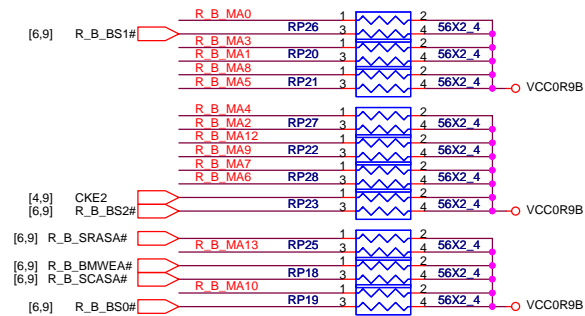
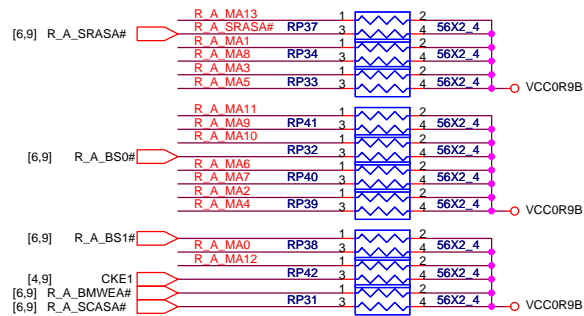

PLACE AT LEAST 1 CAP FOR EACH VDD PINS



**CPU front side bus select**

FSC	FSB	FSA	CPU	SRC	PCI
1	0	1	100	100	33
0	0	1	133	100	33
0	1	1	166	100	33

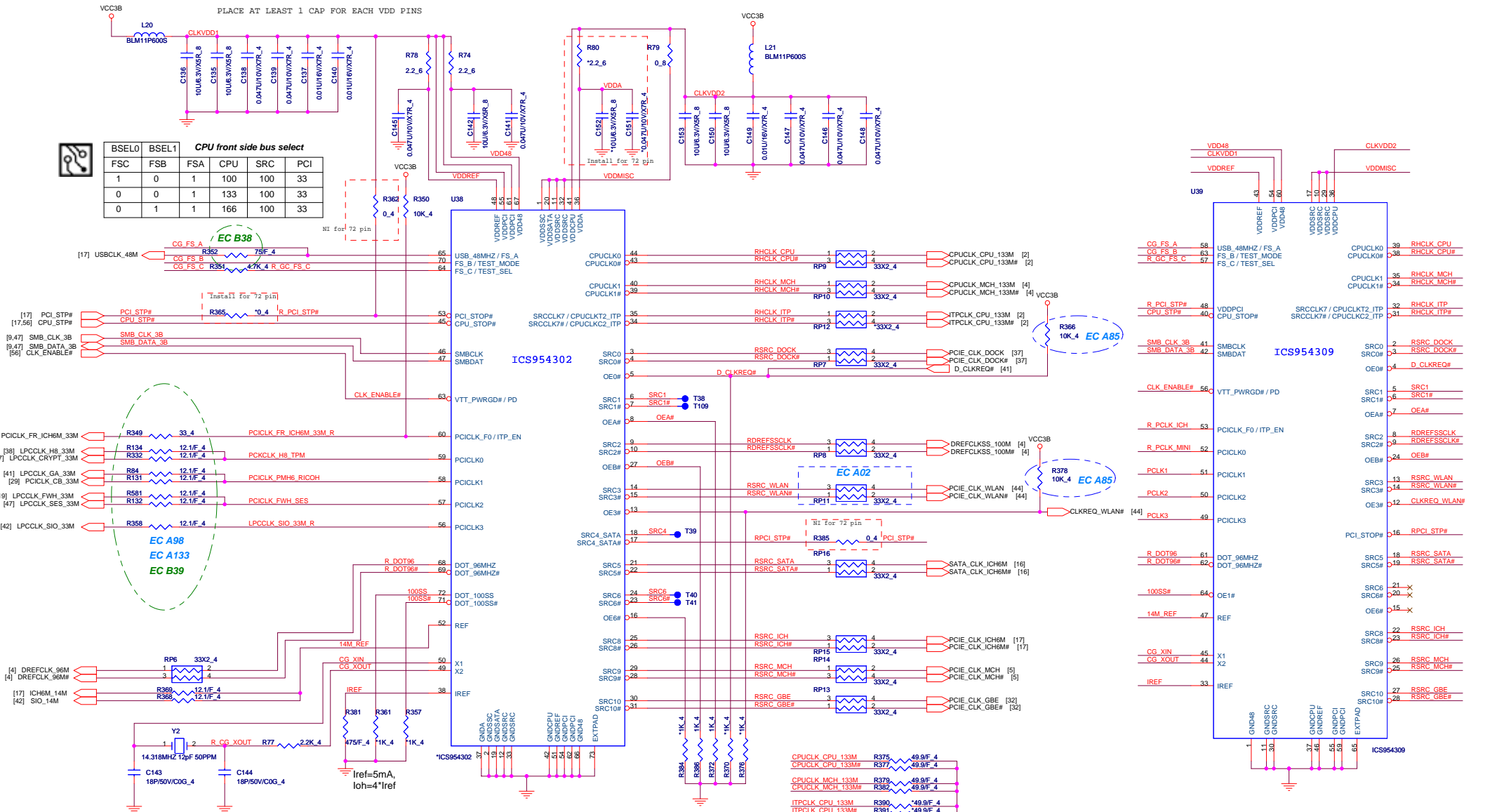

**Clock Generator**

	72 pin	64 pin
U38	954302	NO_ASM
U39	NO_ASM	954309
C152	10uF	NO_ASM
C151	0.047uF	NO_ASM
R80	2.2 ohm	NO_ASM
R362	NO_ASM	0 ohm
R365	0 ohm	NO_ASM
R385	NO_ASM	0 ohm
R361	NO_ASM	NO_ASM

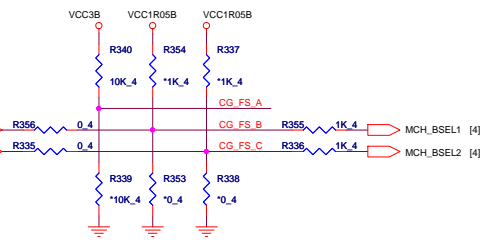

CPUCLK CPU 133M	R375	49.9F	4
CPUCLK CPU 133M#	R377	49.9F	4
CPUCLK MCH 133M	R378	49.9F	4
CPUCLK MCH 133M#	R382	49.9F	4
ITPCLK CPU 133M	R390	49.9F	4
ITPCLK CPU 133M#	R391	49.9F	4
PCI CLK MCH	R394	49.9F	4
PCI CLK MCH#	R395	49.9F	4
DREFCLKSS 100M	R373	49.9F	4
DREFCLKSS 100M#	R374	49.9F	4
PCI CLK ICH6M	R397	49.9F	4
PCI CLK ICH6M#	R396	49.9F	4
PCI CLK GBE	R393	49.9F	4
PCI CLK GBE#	R392	49.9F	4
SATA CLK ICH6M	R399	49.9F	4
SATA CLK ICH6M#	R398	49.9F	4
PCI CLK DOCK	R363	49.9F	4
PCI CLK DOCK#	R364	49.9F	4
DREFCLK 96M	R341	49.9F	4
DREFCLK 96M#	R342	49.9F	4
PCI CLK WLAN	R380	49.9F	4
PCI CLK WLAN#	R383	49.9F	4

**PROJECT : BV1**  
**Quanta Computer Inc.**

Size: Customer Document Number  
Date: Monday, May 09, 2005 Sheet 11 of 72

**CLOCK GENERATOR**

Rev 3A

<BLANK PAGE>

<BLANK PAGE>

# LCD CONNECTOR

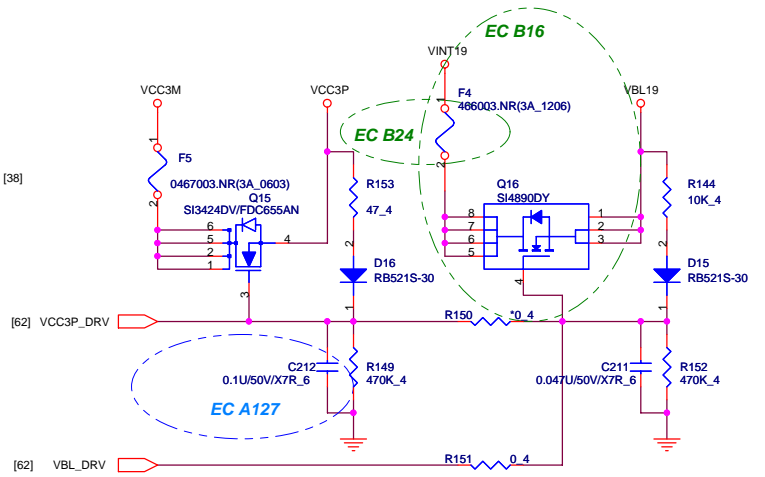
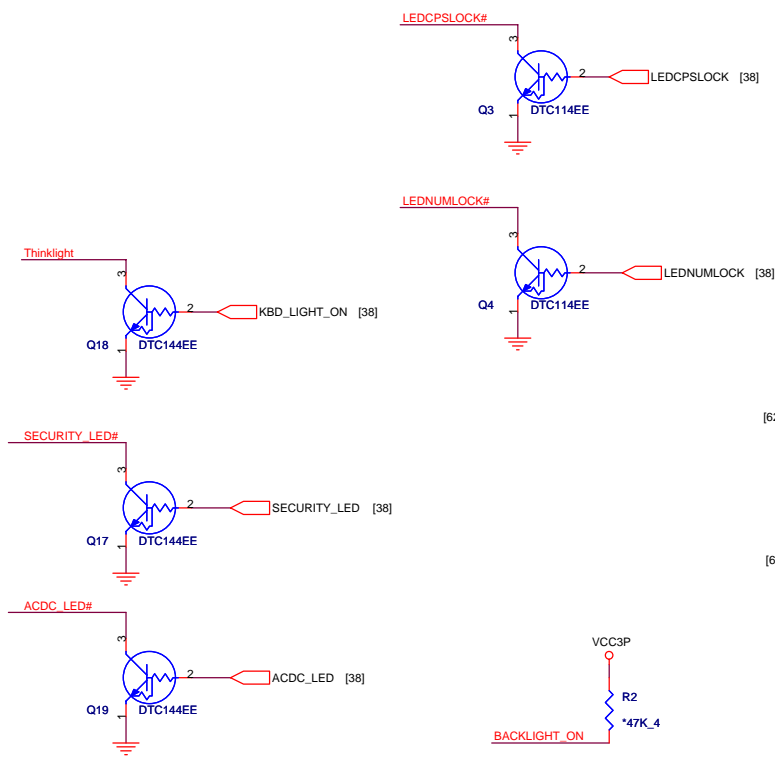
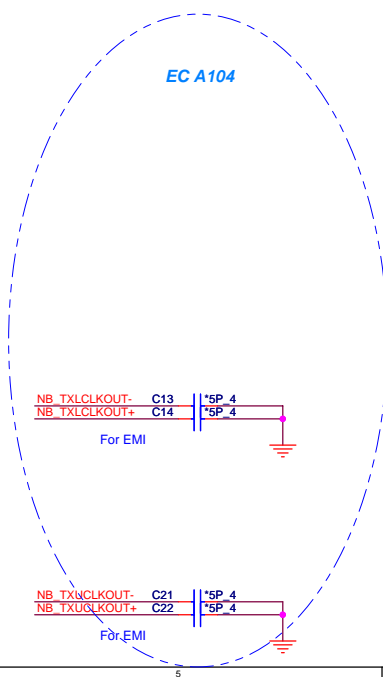
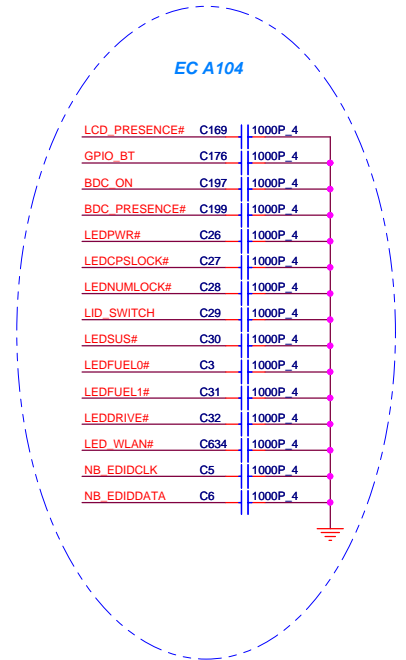
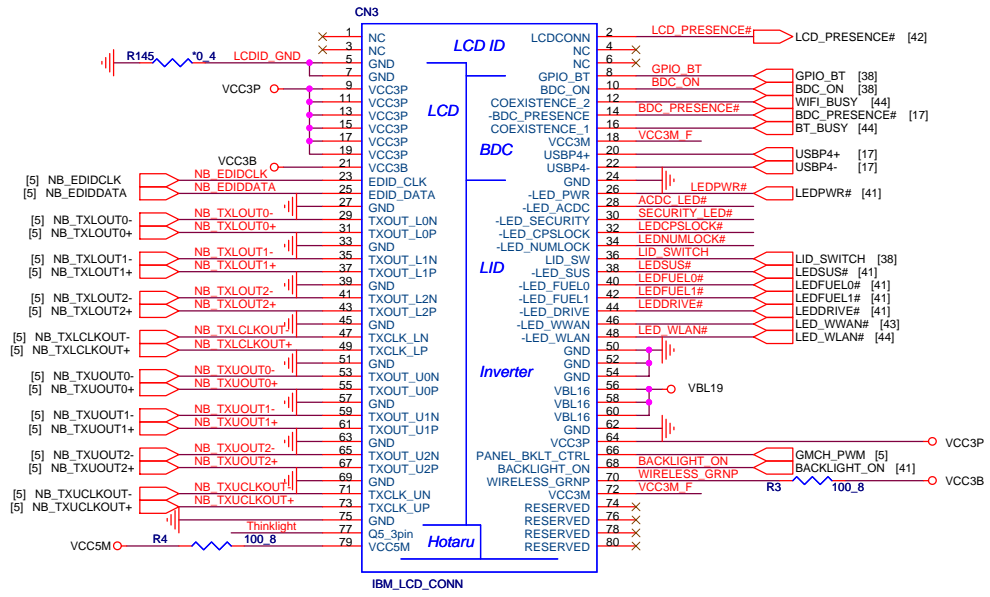
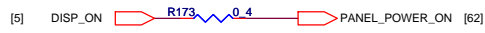
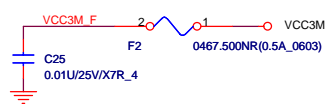
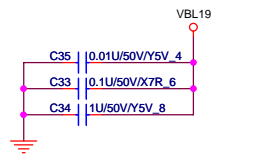
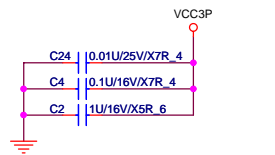

**PROJECT : BV1**  
**Quanta Computer Inc.**

Size Custom	Document Number	<b>LCD/TVOUT</b>	Rev <b>3A</b>
Date: Monday, May 09, 2005	Sheet	14	of 72



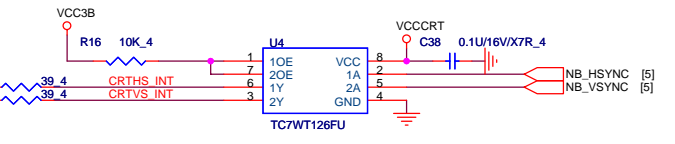
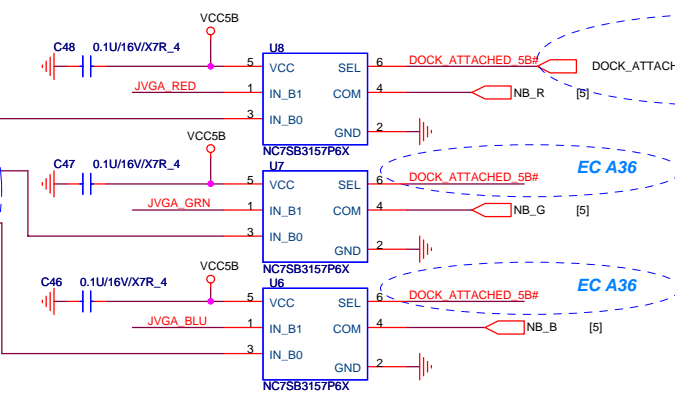
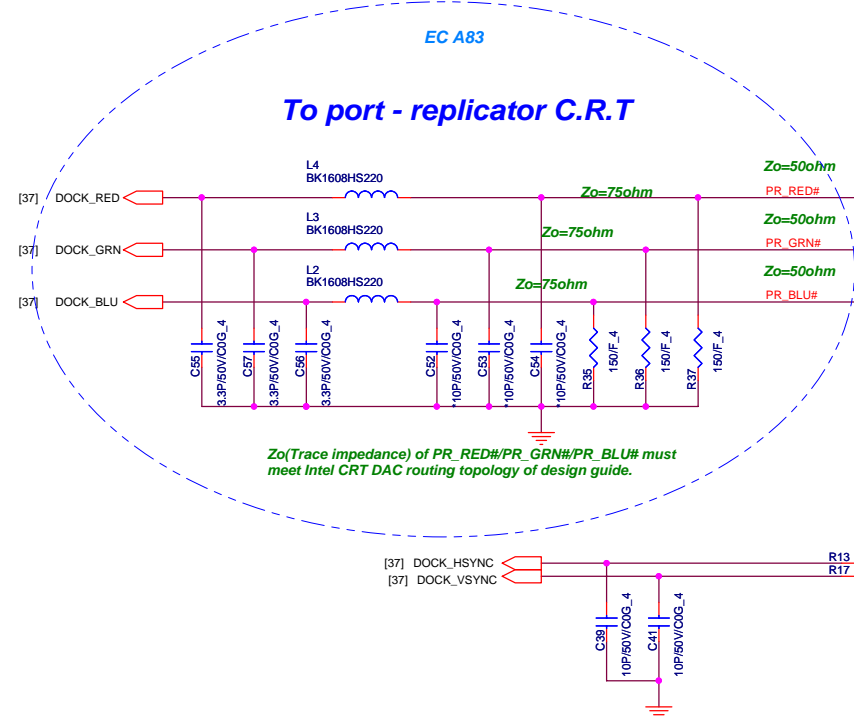
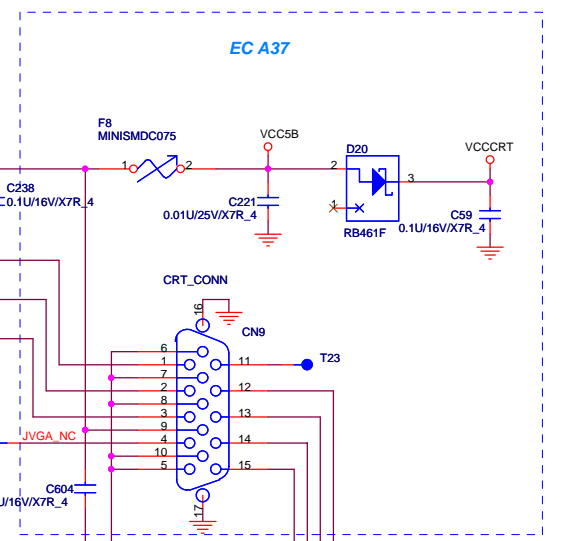
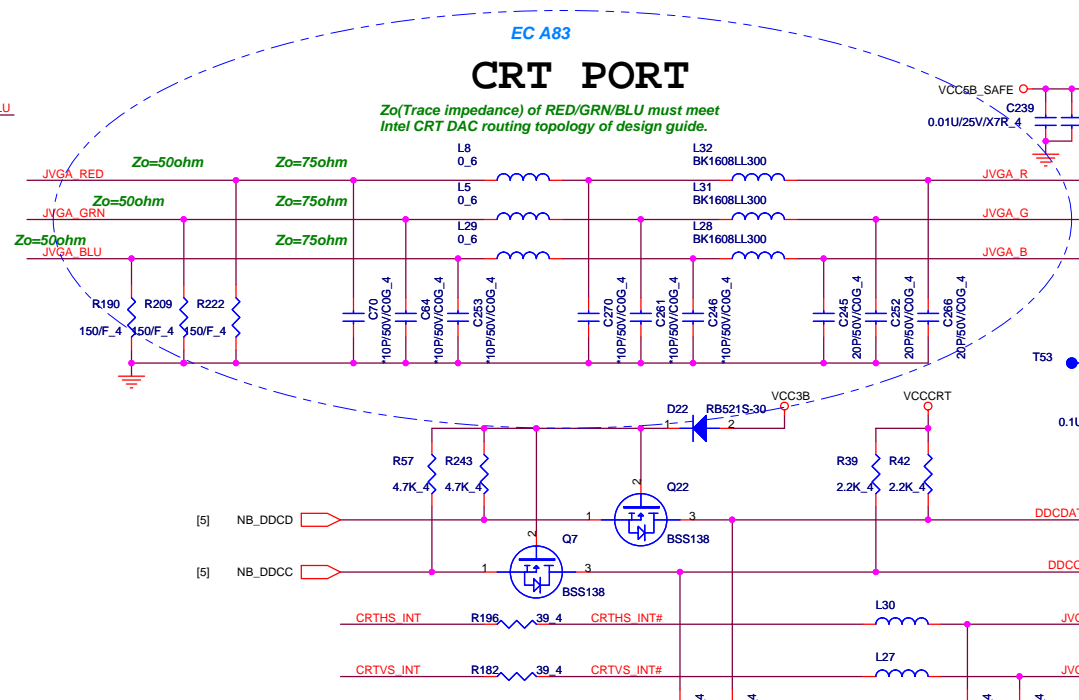
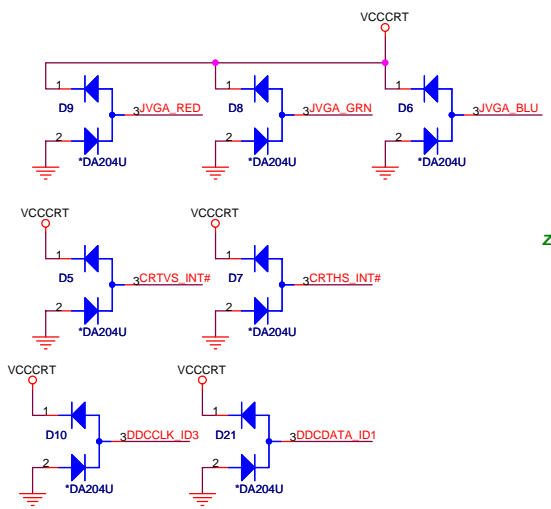

**PROJECT : BV1**  
**Quanta Computer Inc.**

Size Custom	Document Number	<b>CRT PORT</b>	Rev <b>3A</b>
Date: Monday, May 09, 2005		Sheet 15	of 72

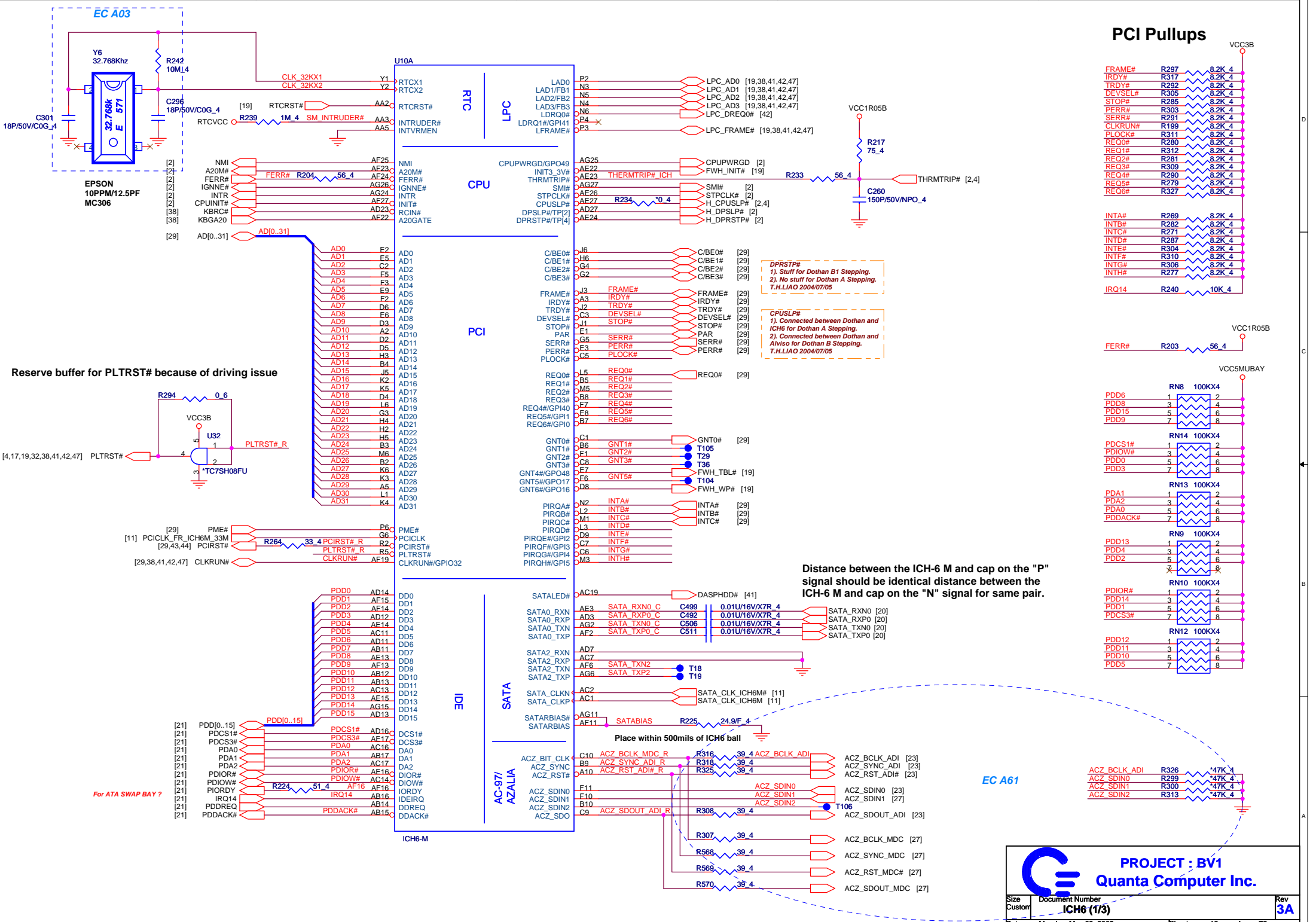

**PCI Pullups**

FRAME#	R297	8.2K	4
TRDY#	R317	8.2K	4
TRDY#	R292	8.2K	4
DEVSEL#	R305	8.2K	4
STOP#	R285	8.2K	4
PERR#	R303	8.2K	4
SERR#	R291	8.2K	4
CLKRUN#	R199	8.2K	4
FLOCK#	R311	8.2K	4
REQ0#	R280	8.2K	4
REQ1#	R312	8.2K	4
REQ2#	R281	8.2K	4
REQ3#	R309	8.2K	4
REQ4#	R290	8.2K	4
REQ5#	R279	8.2K	4
REQ6#	R327	8.2K	4
INTA#	R269	8.2K	4
INTB#	R282	8.2K	4
INTC#	R271	8.2K	4
INTD#	R287	8.2K	4
INTE#	R310	8.2K	4
INTF#	R306	8.2K	4
INTG#	R277	8.2K	4
IRQ14	R240	10K	4

FERR#	R203	56	4
PDD6	1	2	
PDD8	3	4	
PDD15	5	6	
PDD9	7	8	
PDCS1#	1	2	
PDIOW#	3	4	
PDD0	5	6	
PDD3	7	8	
PDA1	1	2	
PDA2	3	4	
PDA0	5	6	
PDDACK#	7	8	
PDD13	1	2	
PDD4	3	4	
PDD2	5	6	
PDIOR#	7	8	
PDD1	1	2	
PDD14	3	4	
PDD3	5	6	
PDCS3#	7	8	
PDD12	1	2	
PDD11	3	4	
PDD10	5	6	
PDD5	7	8	
PDD1	1	2	
PDD14	3	4	
PDD3	5	6	
PDCS3#	7	8	
PDD12	1	2	
PDD11	3	4	
PDD10	5	6	
PDD5	7	8	

ACZ_BCLK_ADI	R326	*47K	4
ACZ_SDINO	R299	*47K	4
ACZ_SDI1	R300	*47K	4
ACZ_SDI2	R313	*47K	4

**PROJECT : BV1**  
**Quanta Computer Inc.**

Size Custom Document Number **ICH6 (1/3)** Rev **3A**  
 Date: Monday, May 09, 2006 Sheet 16 of 72



USB distribution

USB0	USB Port 1
USB1	USB Port 2
USB2	USB Port 3
USB3	Docking
USB4	Bluetooth
USB5	Finger print
USB6	N/A
USB7	MINI PCI-E Card

PCI-E distribution

PCI-E0	Ethernet Controller
PCI-E1	N/A
PCI-E2	Docking
PCI-E3	MINI PCI-E Card

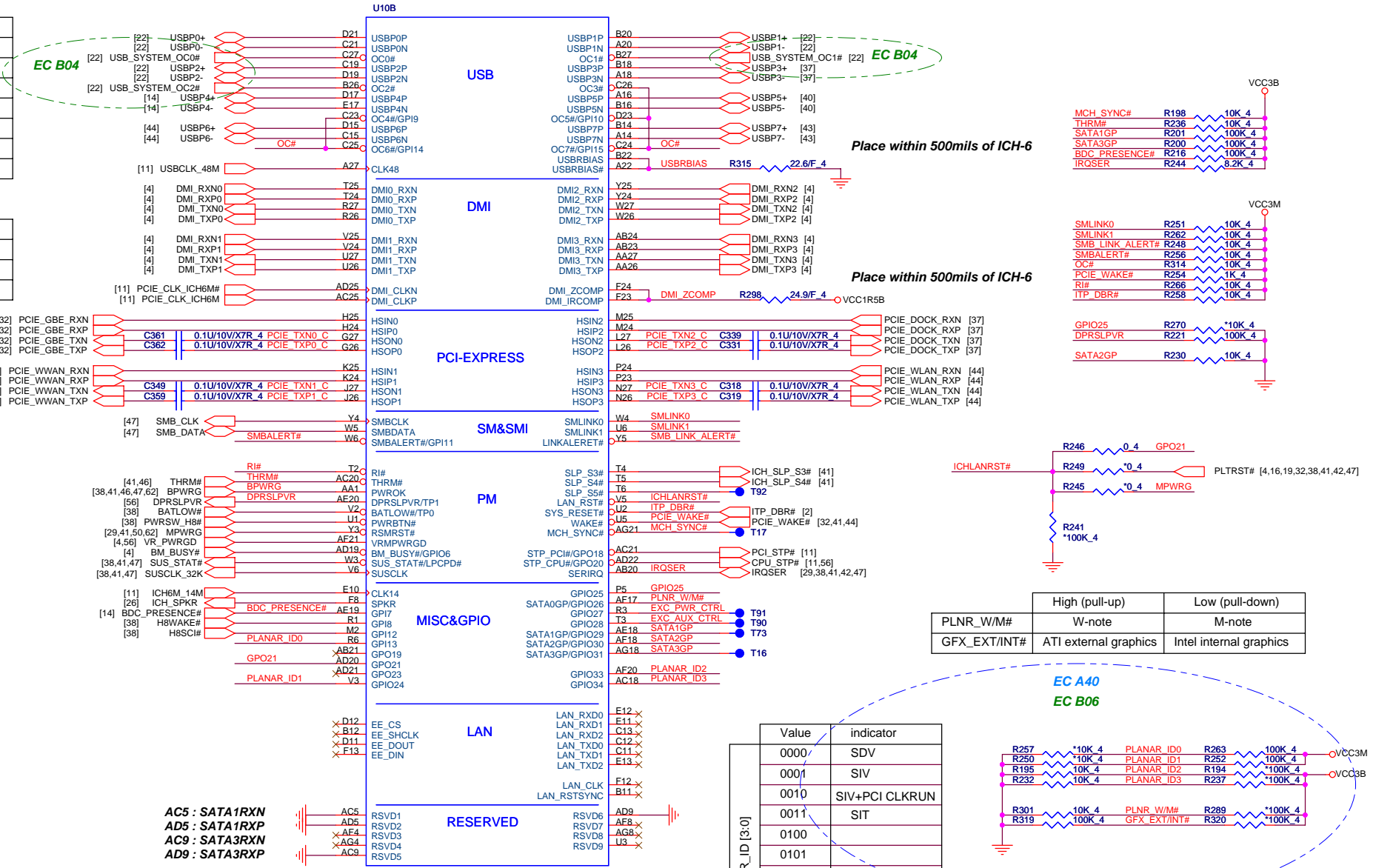

PLNR_W/M#	High (pull-up)	Low (pull-down)
	W-note	M-note
GFX_EXT/INT#	ATI external graphics	Intel internal graphics

**PROJECT : BV1**  
**Quanta Computer Inc.**

Size Custom	Document Number <b>ICH6 (2/3)</b>	Rev <b>3A</b>
Date: Monday, May 09, 2006	Sheet 17	of 72



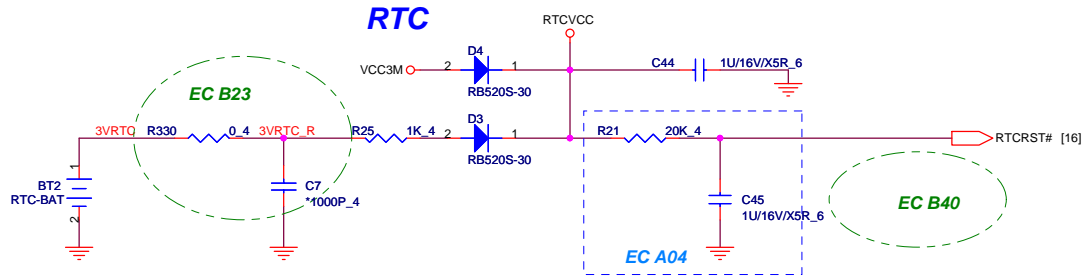

11/24 Change BT1 to be Tyco "1470366-2" and use cable-type coin battery

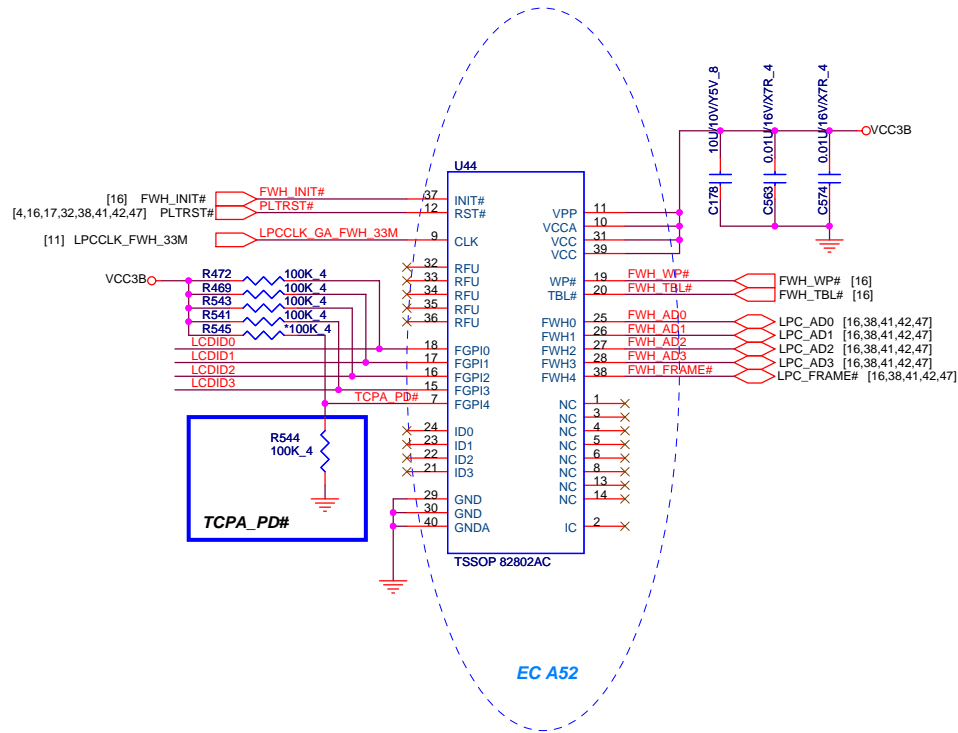

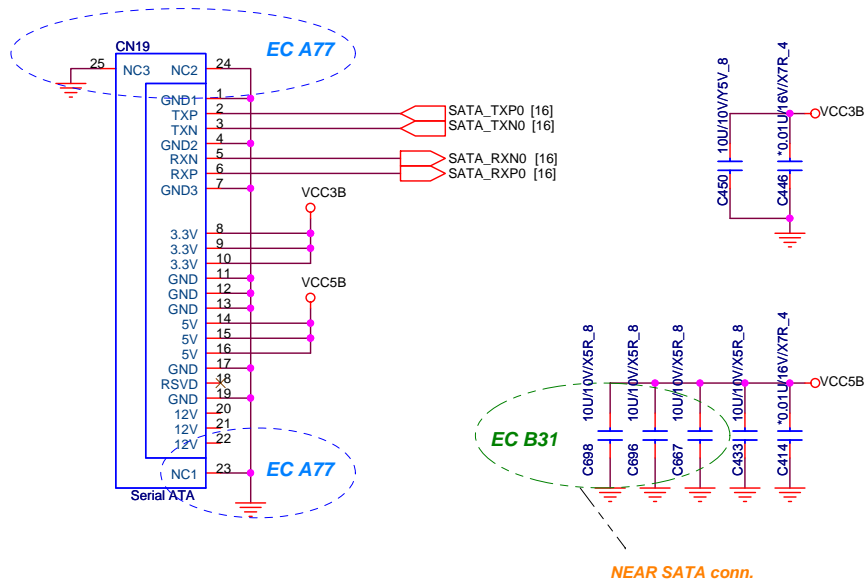

NEAR SATA conn.



# ODD CONNECTOR

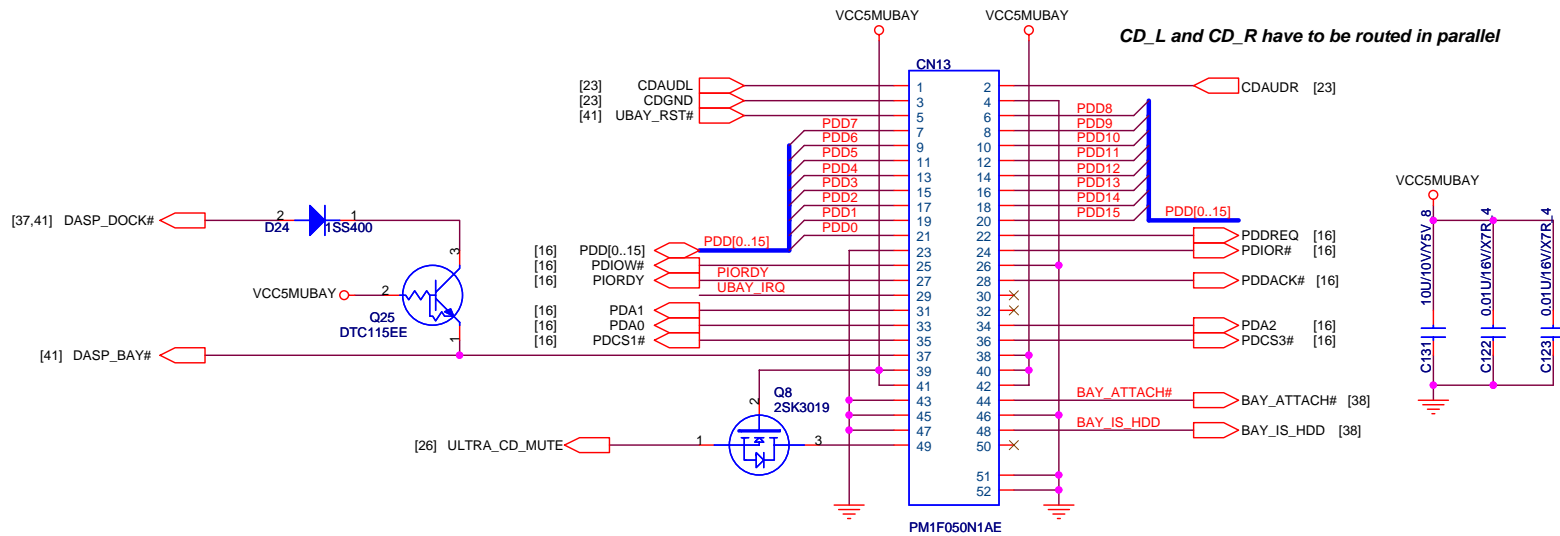

CD\_L and CD\_R have to be routed in parallel

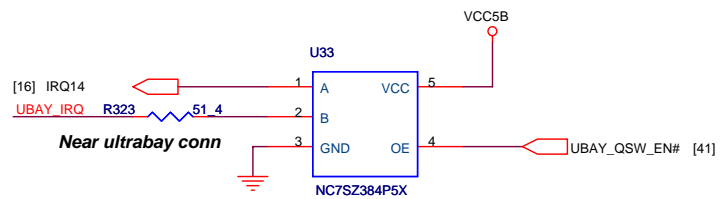

	BAY_ATTACH#	BAY_IS_HDD
NO_DEVICE	H	Don't care
OPTICAL	L	L
HDD	L	H

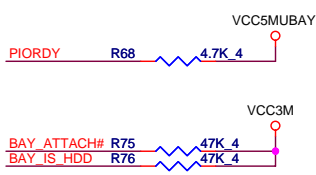

**PROJECT : BV1**  
**Quanta Computer Inc.**

Size	Document Number	Rev
Custom	<b>BAY I/F CONN</b>	<b>3A</b>
Date:	Monday, May 09, 2005	Sheet 21 of 72

USB port(straddle type) \*2

1. Common mode choke coil : TDK ACM2012-900 (reserved)

Place these resistors as the choke coil are also placed on the same pads of these two 0ohm resistors (0603size)

2. PGB0010603 ESD diode and 150U cap should close to USB conn

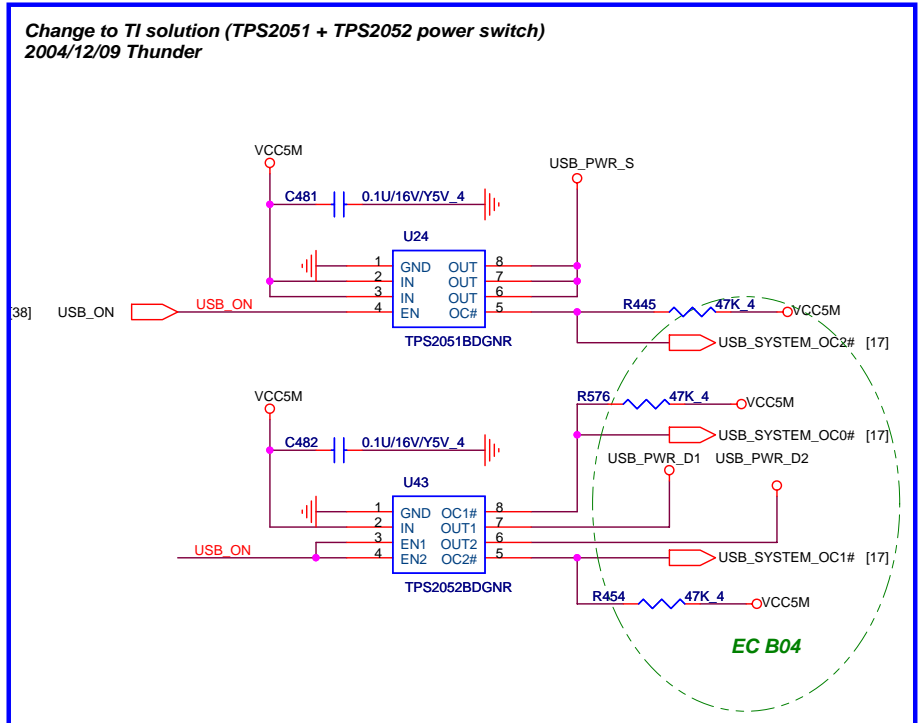
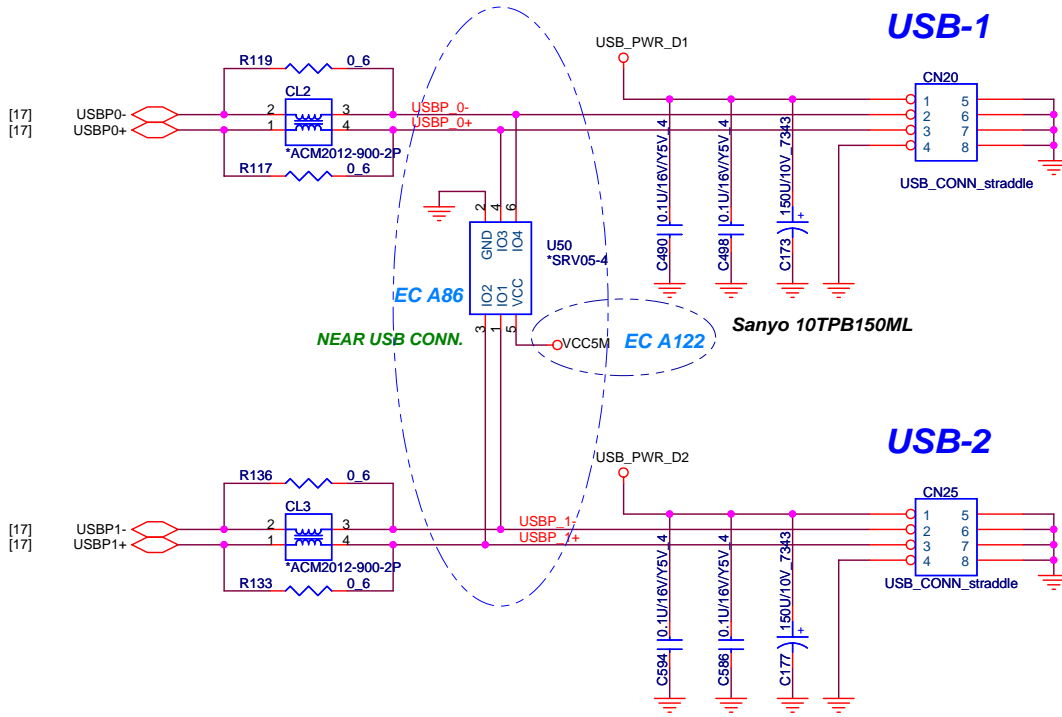

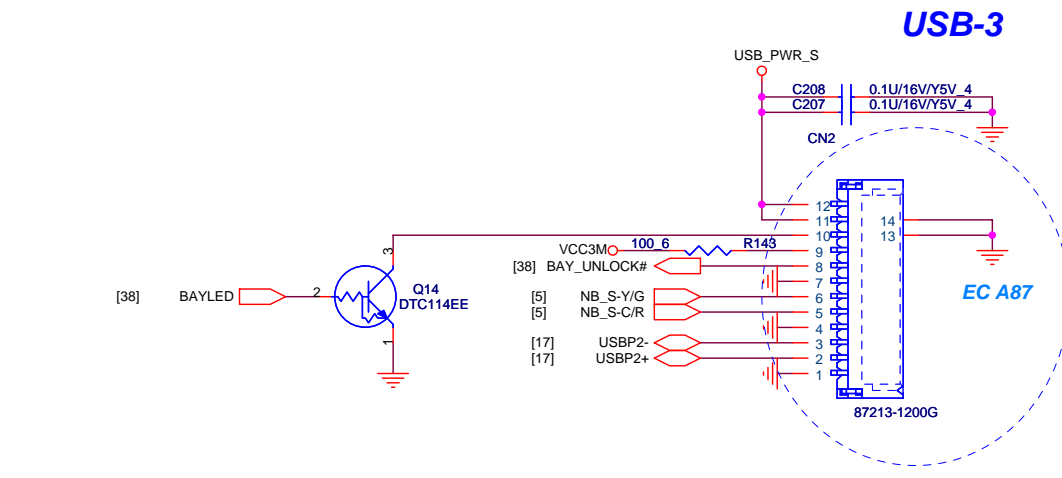
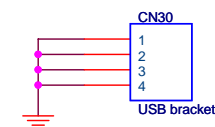

USB Bracket

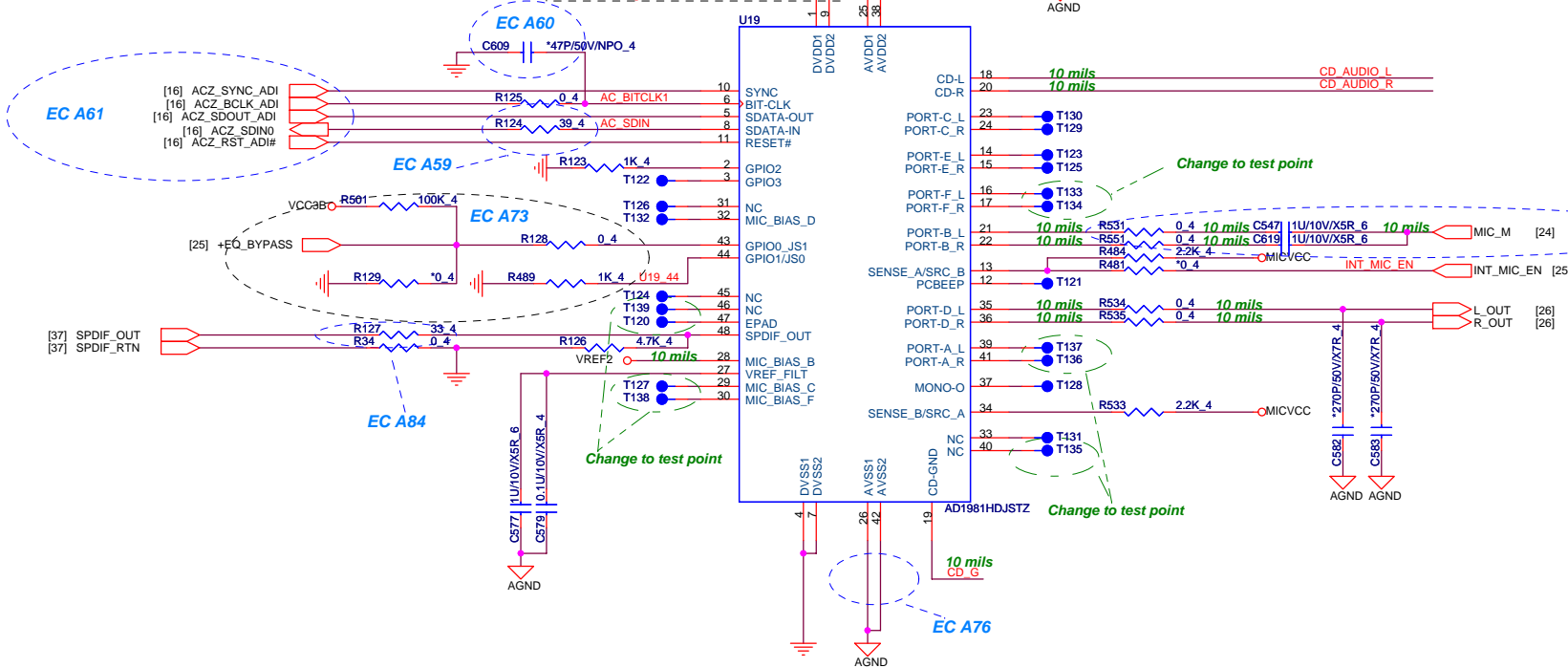
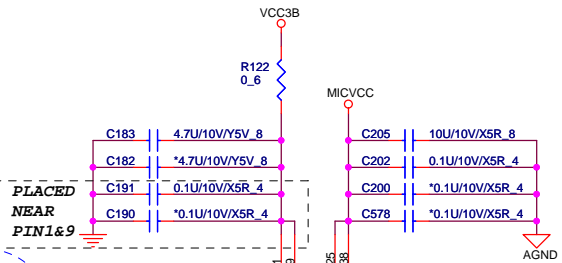
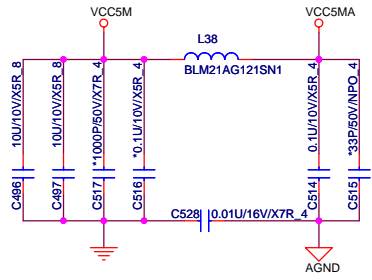
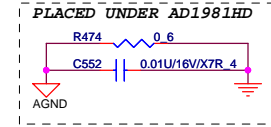
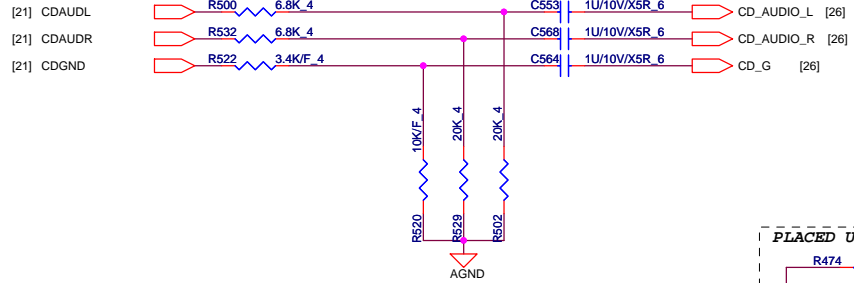
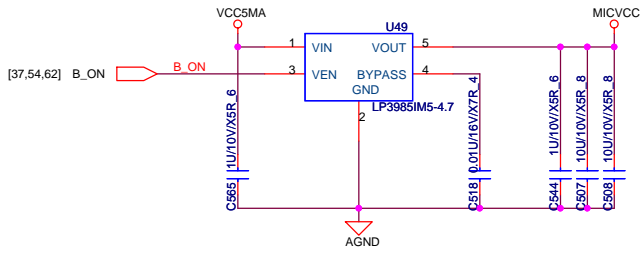

USB-3

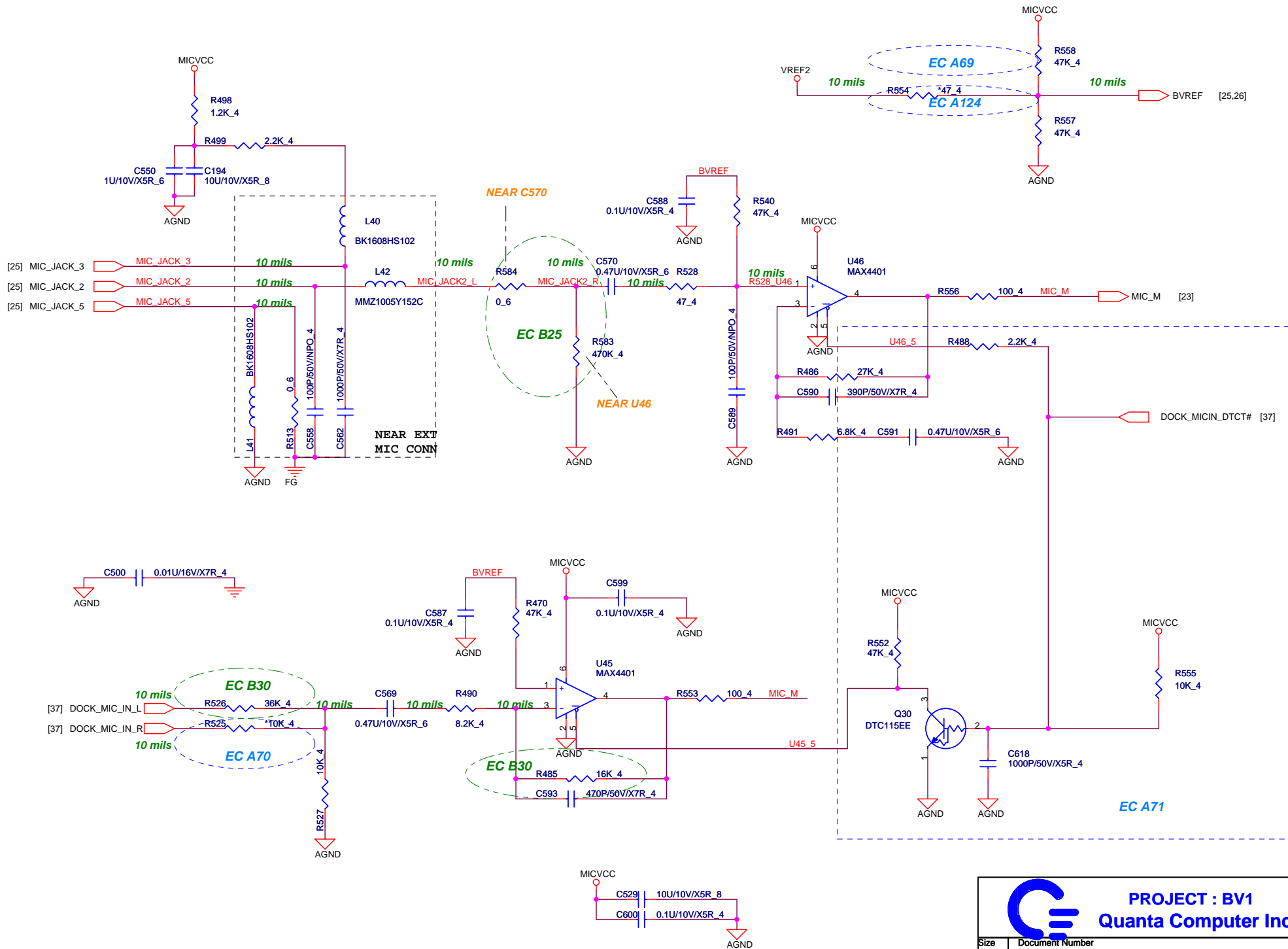



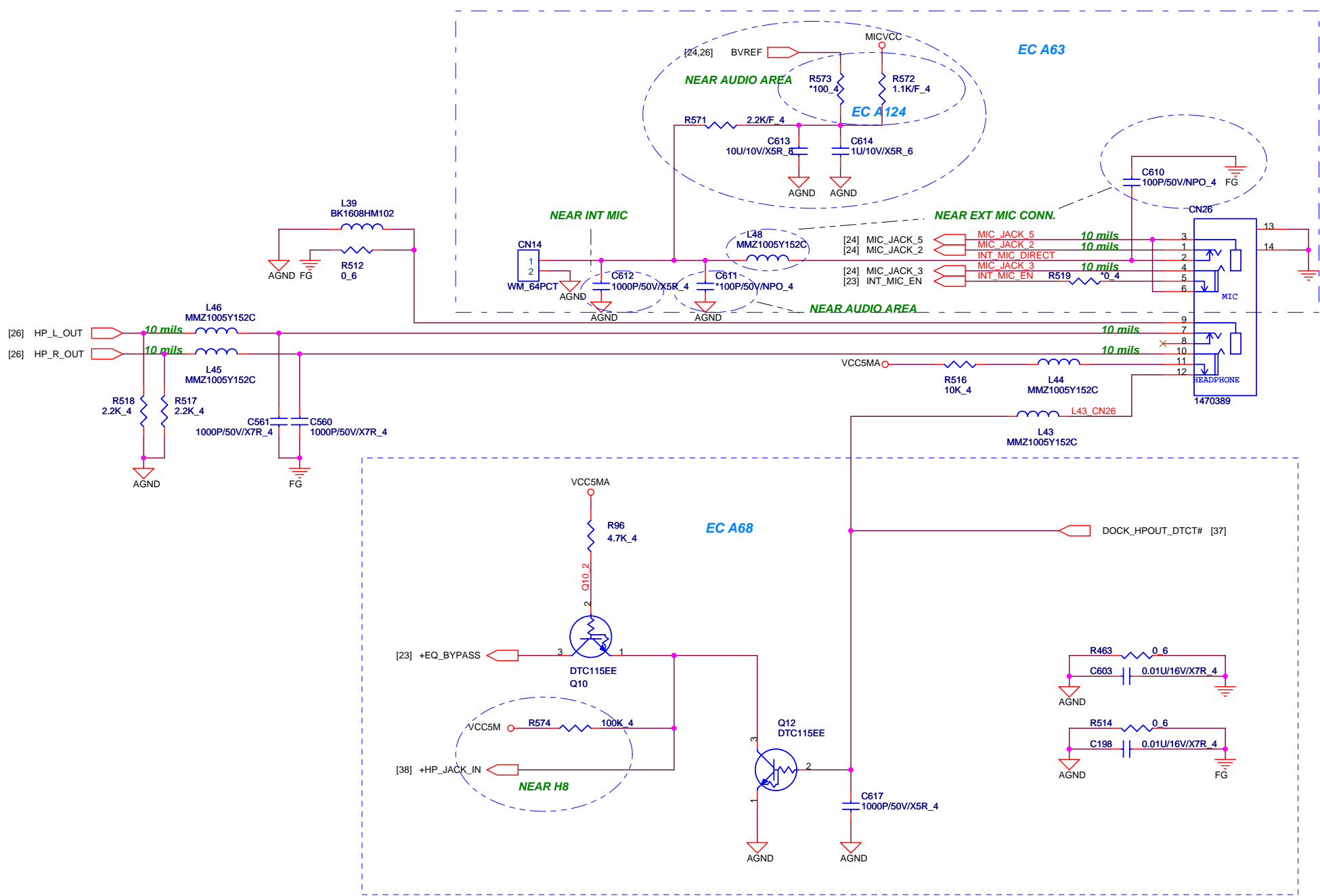

**PROJECT : BV1**  
**Quanta Computer Inc.**

Size	Document Number	Rev
Custom	<b>AUDIO_HP_MIC</b>	<b>3A</b>
Date:	Monday, May 09, 2005	Sheet 24 of 72

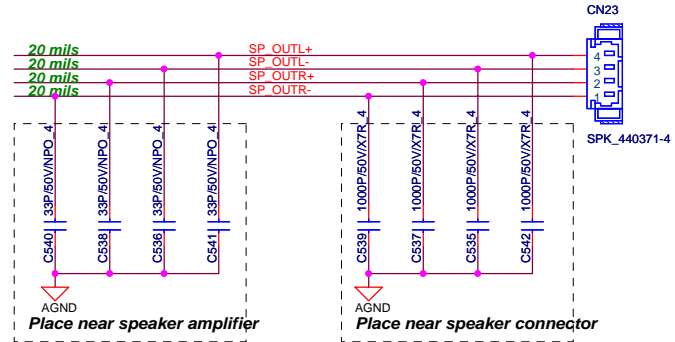
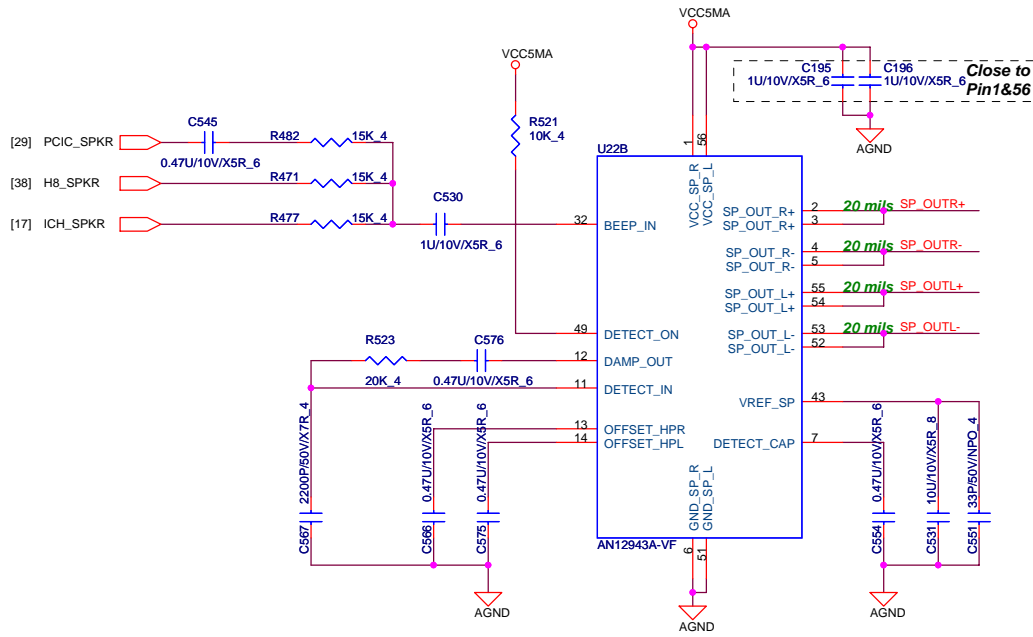
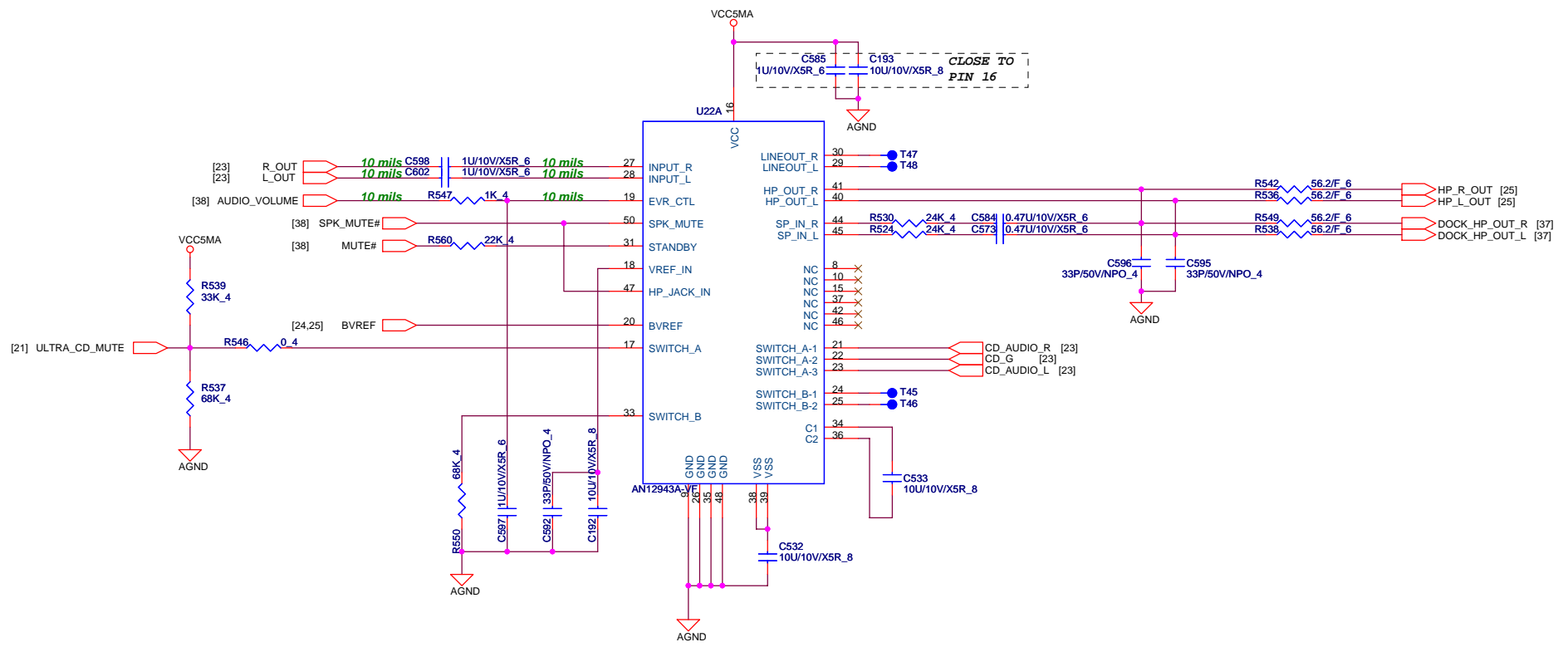



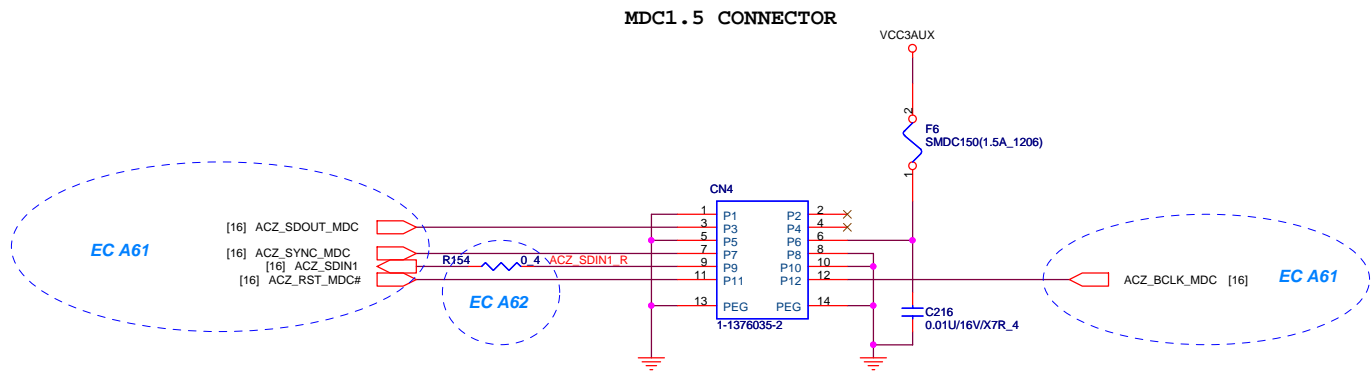



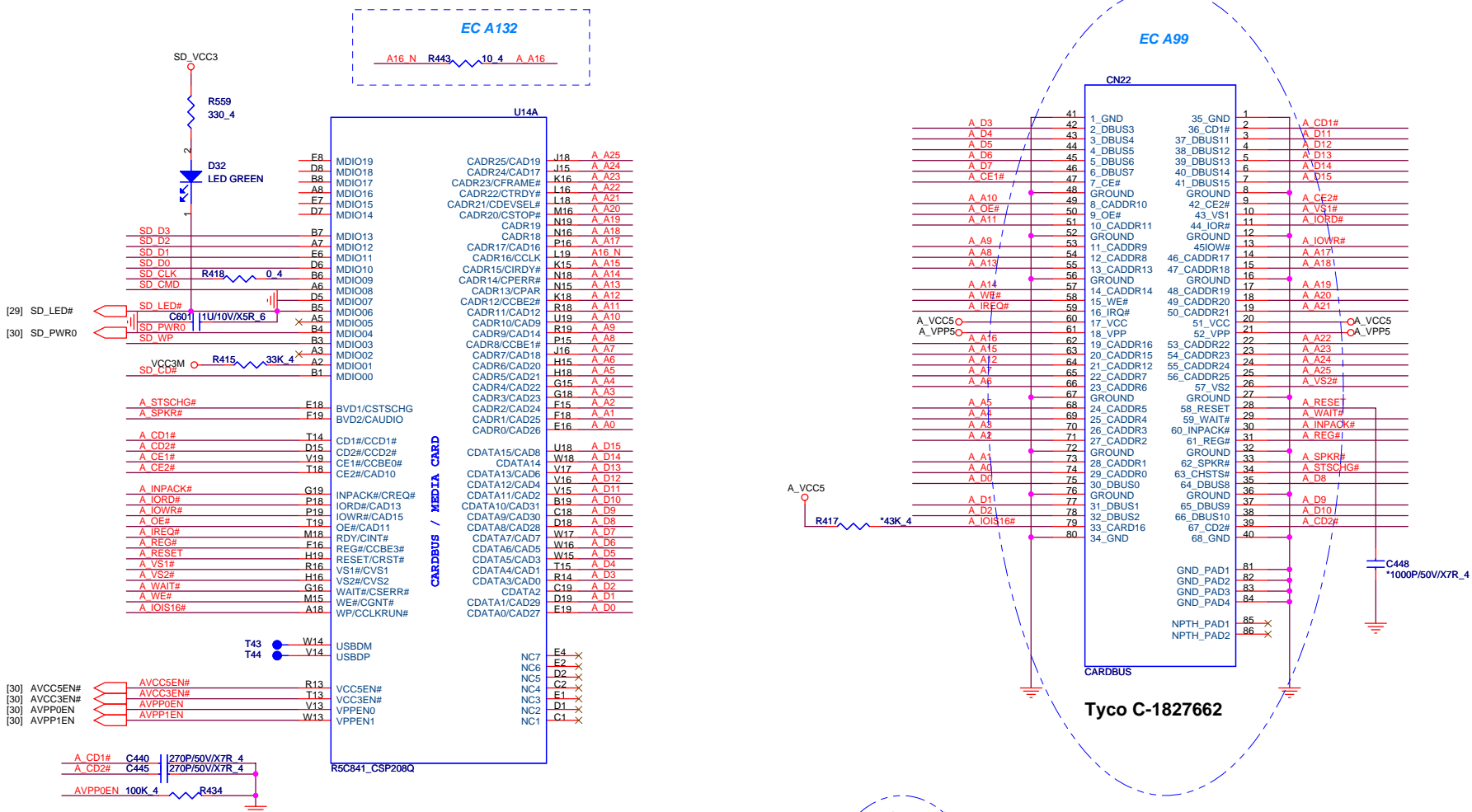

**PROJECT : BV1**  
**Quanta Computer Inc.**

Size Custom Document Number **R5C841(CARDBUS)-1** Rev **3A**

Date: Monday, May 09, 2005 Sheet 28 of 72





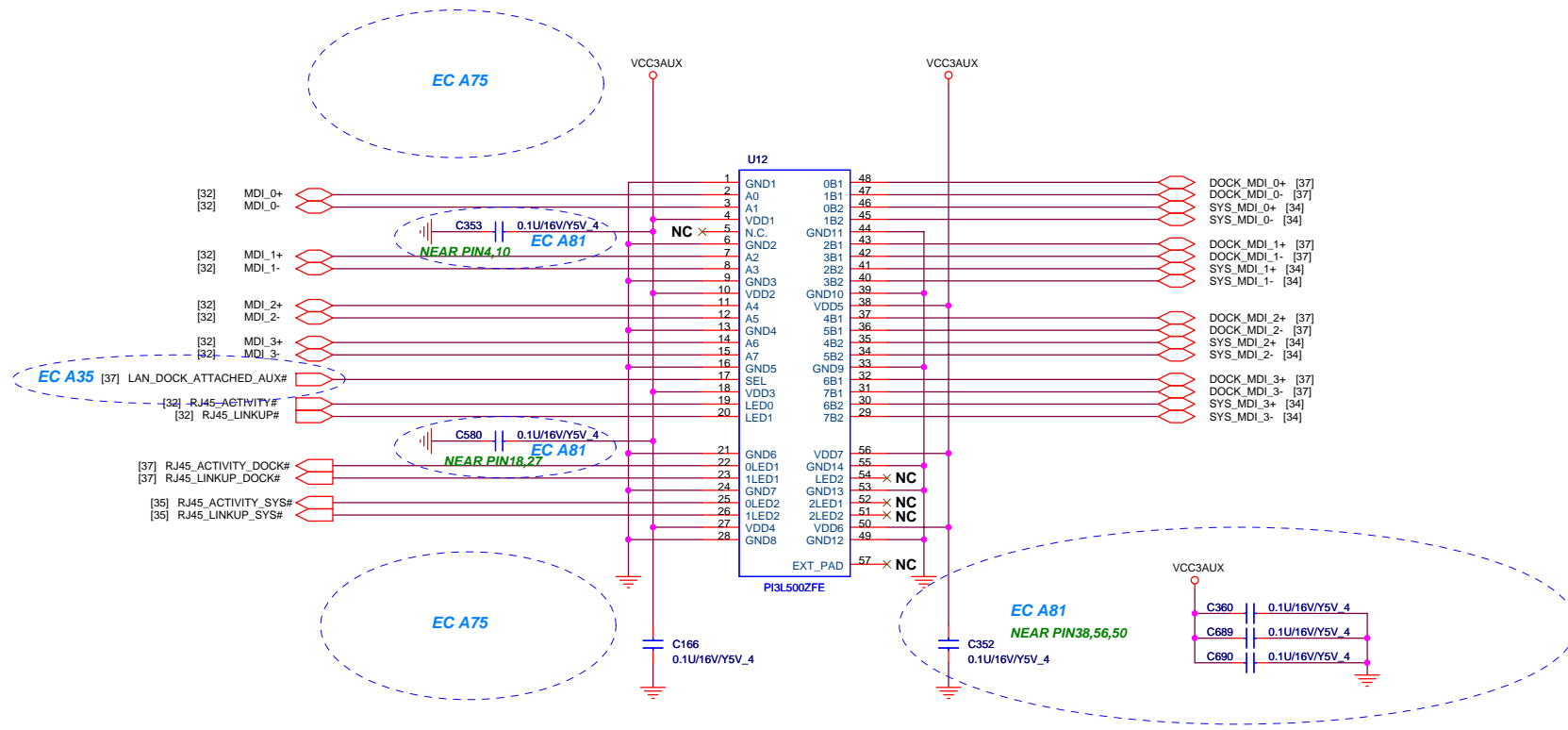

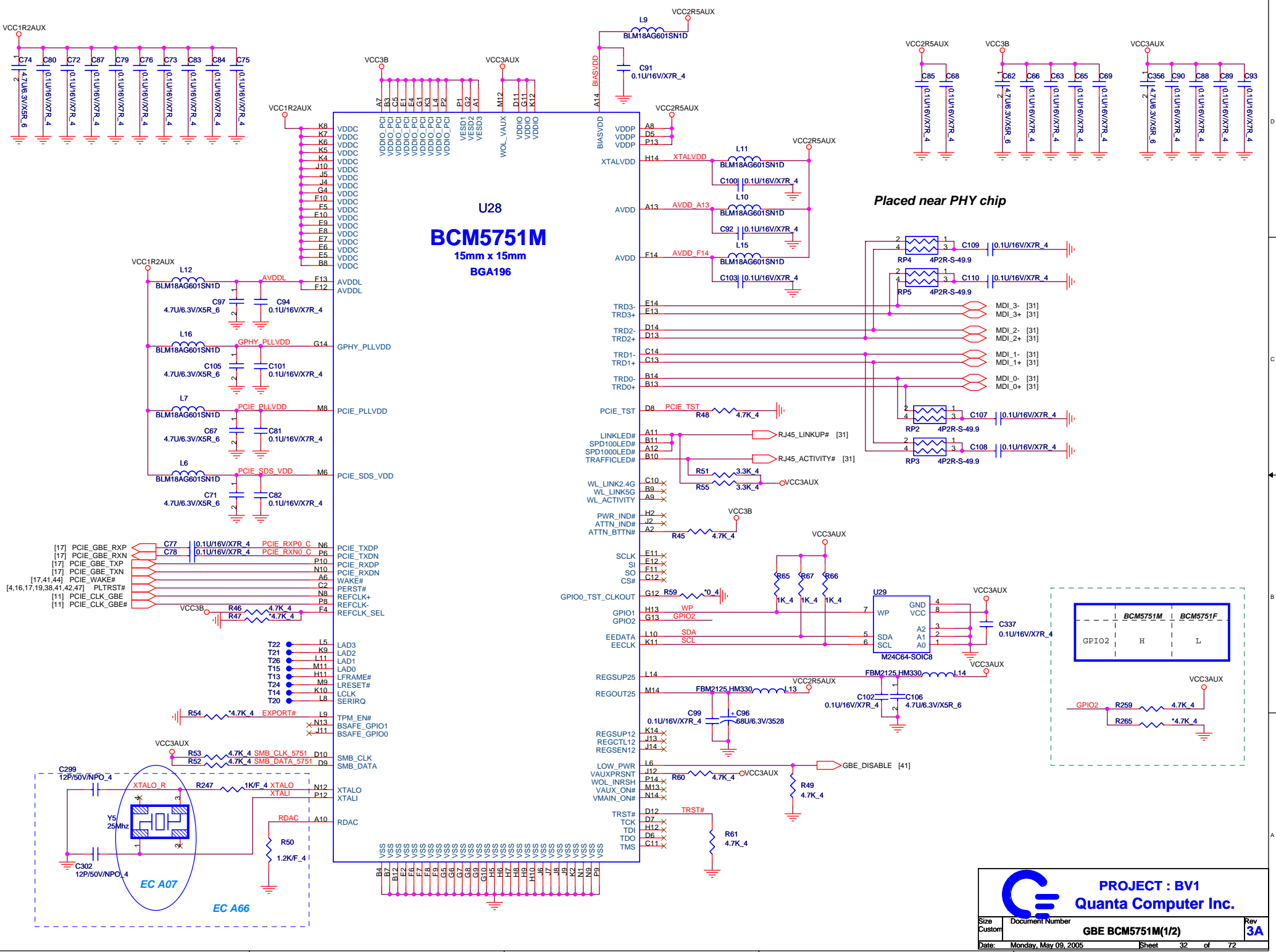

**U28**  
**BCM5751M**  
 15mm x 15mm  
 BGA196

Placed near PHY chip

		BCM5751M	BCM5751F
GPIO2	H		L

**PROJECT : BV1**  
**Quanta Computer Inc.**

Size Custom Document Number **GBE BCM5751M(1/2)** Rev **3A**

Date: Monday, May 09, 2005 Sheet 32 of 72



<BLANK PAGE>

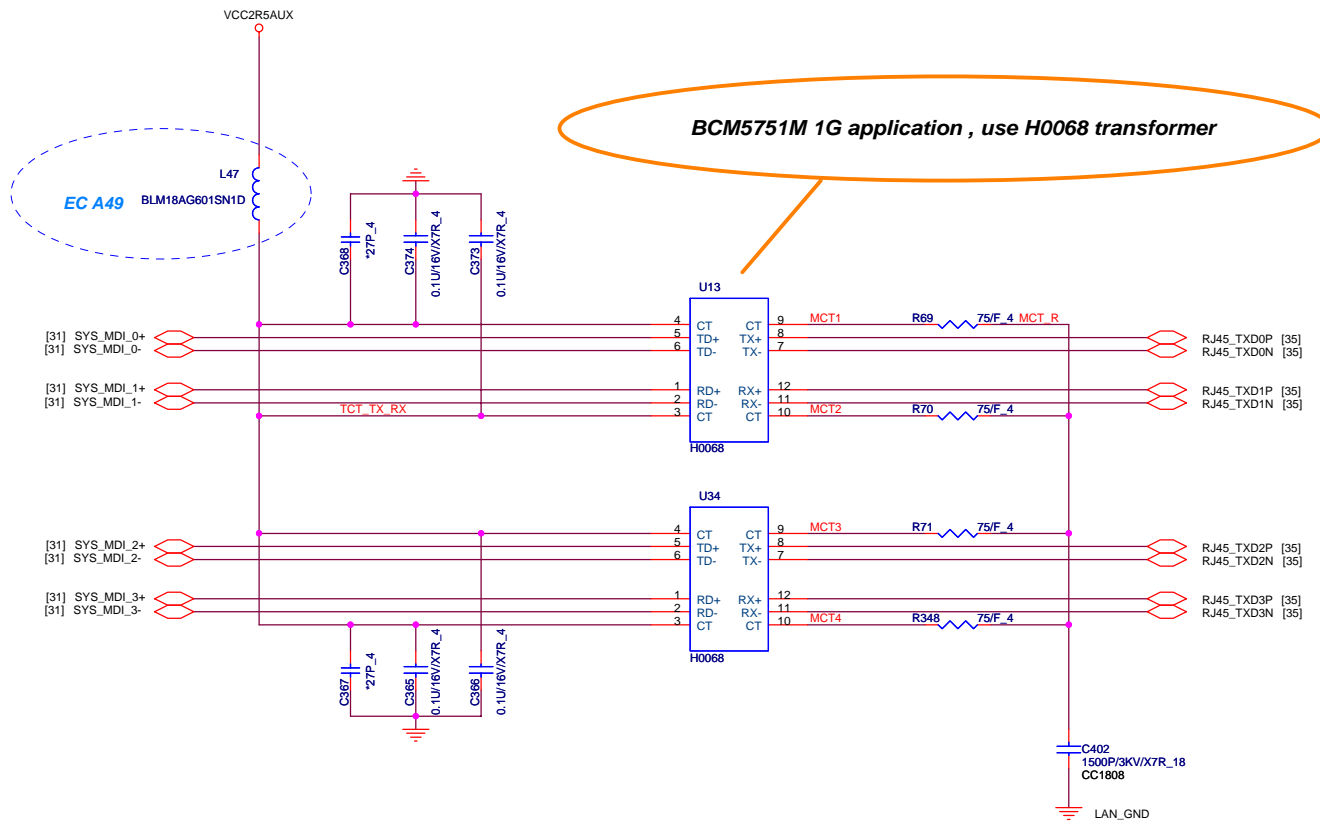

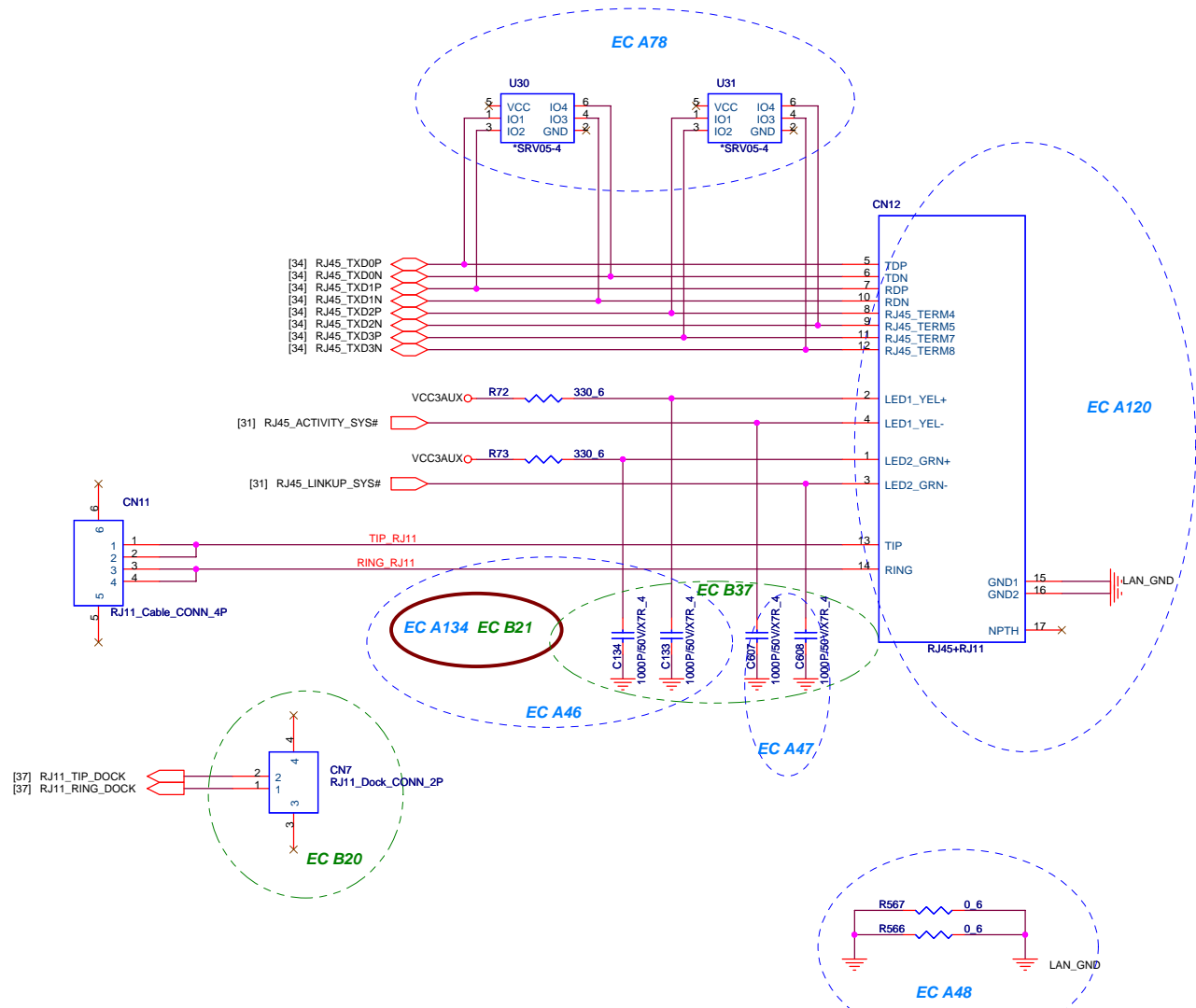

Close to Dock

BLANK

		<b>PROJECT : BV1</b>	
		<b>Quanta Computer Inc.</b>	
Size	Document Number	<b>MINI PCI SLOT</b>	Rev
Custom			<b>3A</b>
Date:	Monday, May 09, 2005	Sheet	36 of 72

Debug CONN

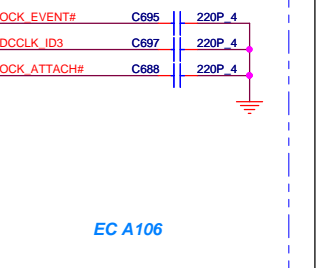
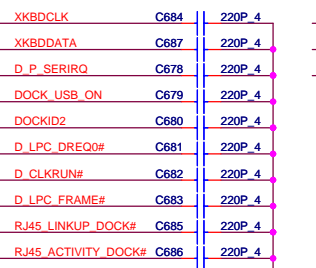
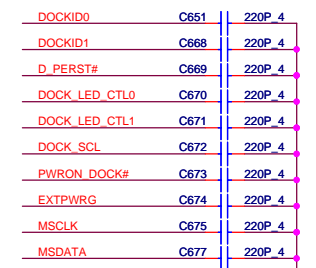
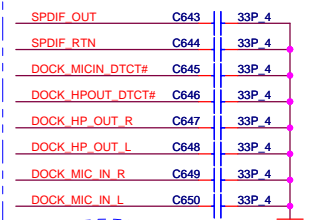
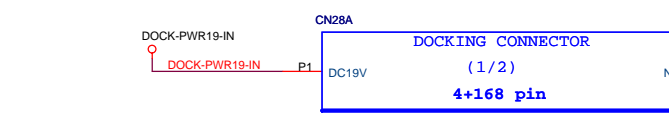
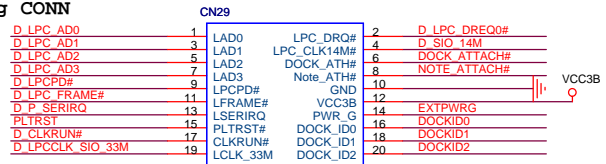

EC A106

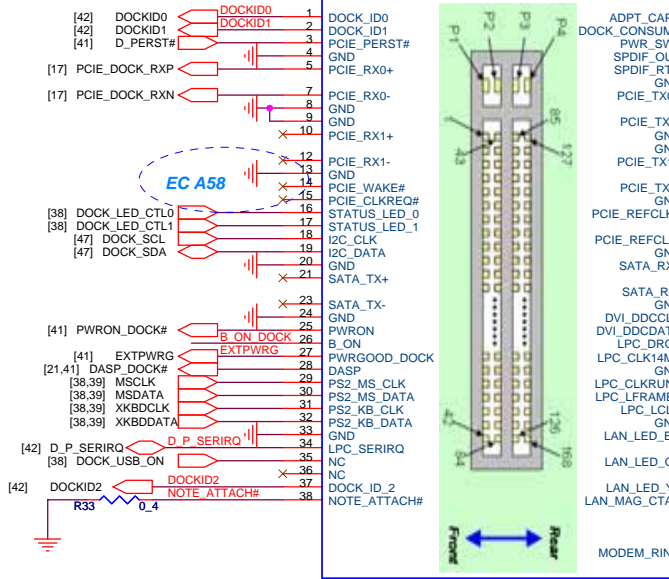

IBM\_DOCKING\_CONN\_new

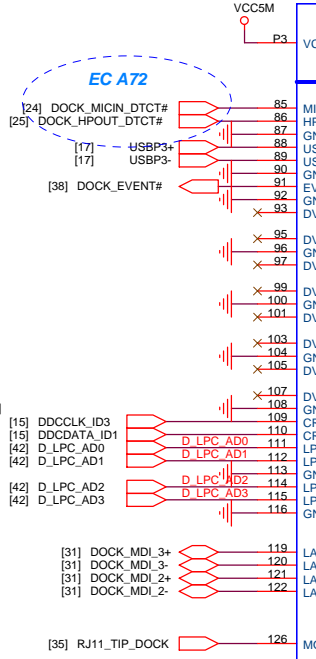
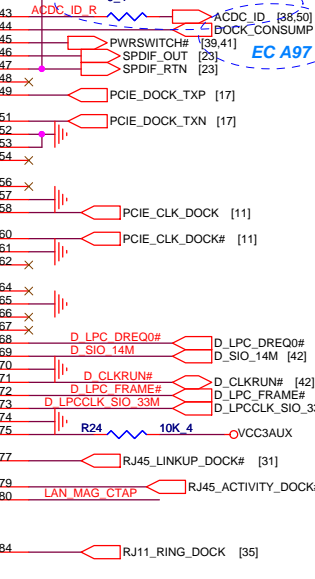

EC A72

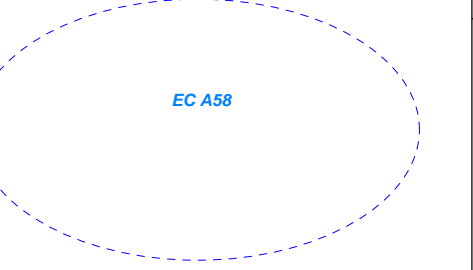
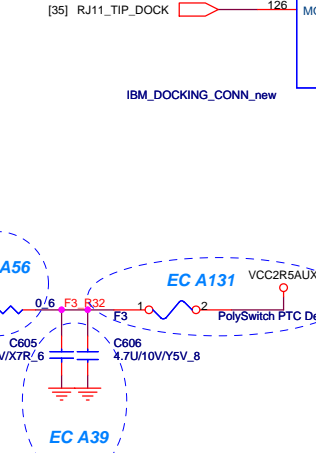
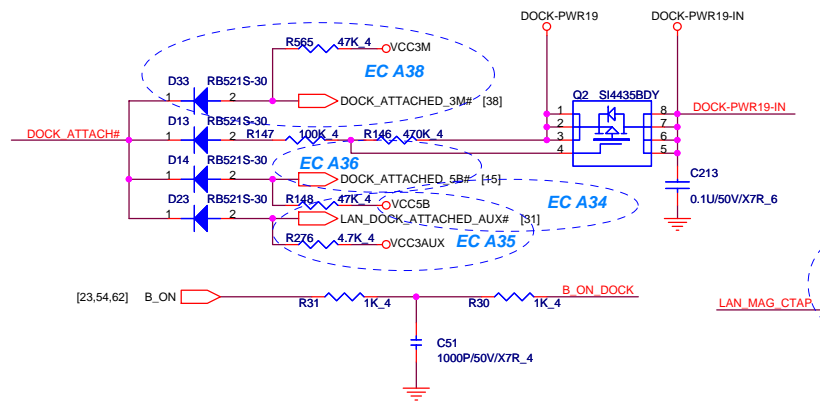
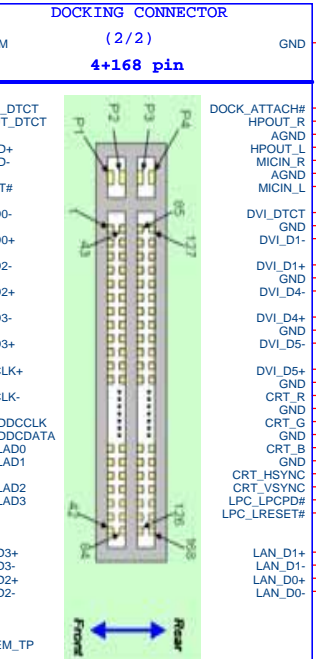

**PROJECT : BV1**  
**Quanta Computer Inc.**

Size Custom	Document Number	<b>Docking</b>	Rev <b>3A</b>
Date: Tuesday, May 10, 2005	Sheet 37	of 72	



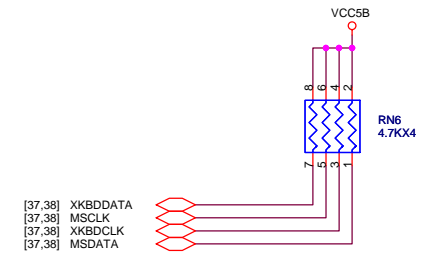
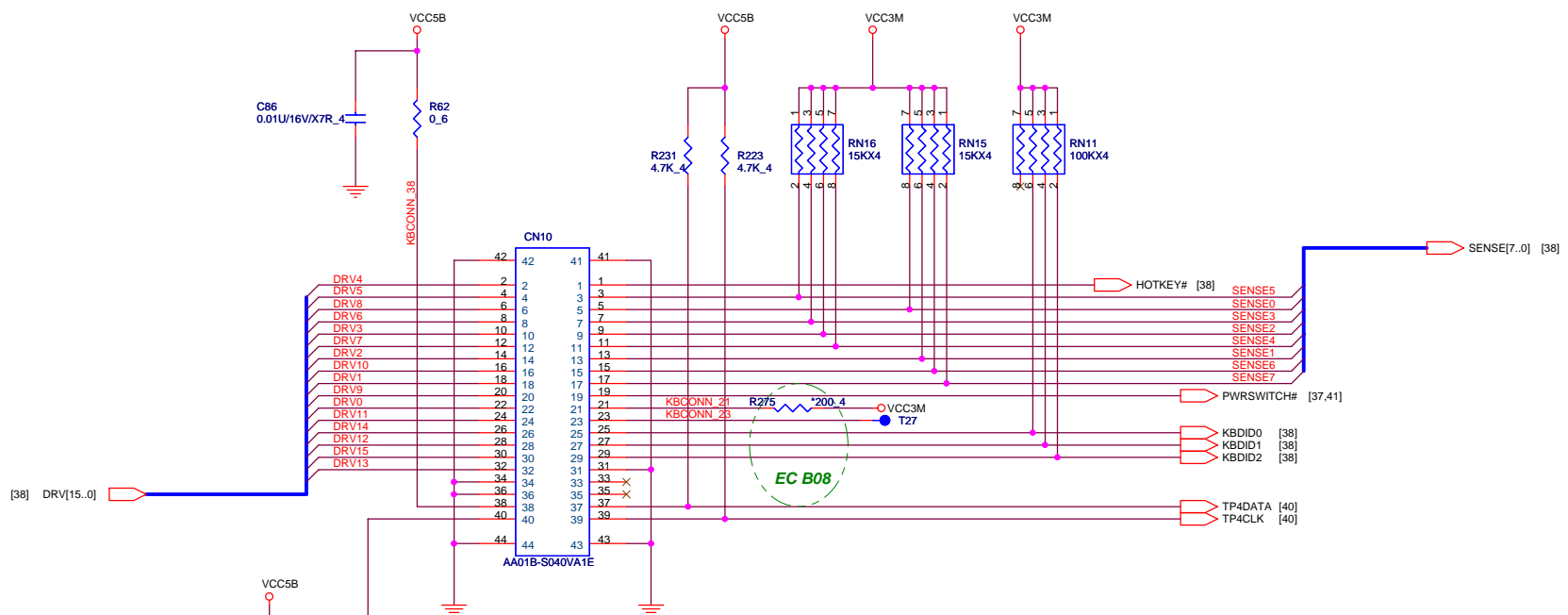

EC A105

DRV1	C626	100P_4
DRV2	C627	100P_4
DRV3	C628	100P_4
DRV4	C629	100P_4
DRV5	C630	100P_4
DRV6	C631	100P_4
DRV7	C632	100P_4
DRV8	C633	100P_4
DRV9	C635	100P_4
DRV10	C636	100P_4
DRV11	C637	100P_4
DRV12	C638	100P_4
DRV13	C639	100P_4
DRV14	C640	100P_4
DRV15	C641	100P_4
TP4_RESET	C642	100P_4
SENSE0	C676	100P_4
SENSE1	C652	100P_4
SENSE2	C653	100P_4
SENSE3	C654	100P_4
SENSE4	C655	100P_4
SENSE5	C656	100P_4
SENSE6	C657	100P_4
SENSE7	C658	100P_4
PWRSWITCH#	C659	100P_4
KBCONN_21	C660	100P_4
KBDID0	C661	100P_4
KBDID1	C662	100P_4
KBDID2	C663	100P_4
TP4DATA	C664	100P_4
TP4CLK	C665	100P_4

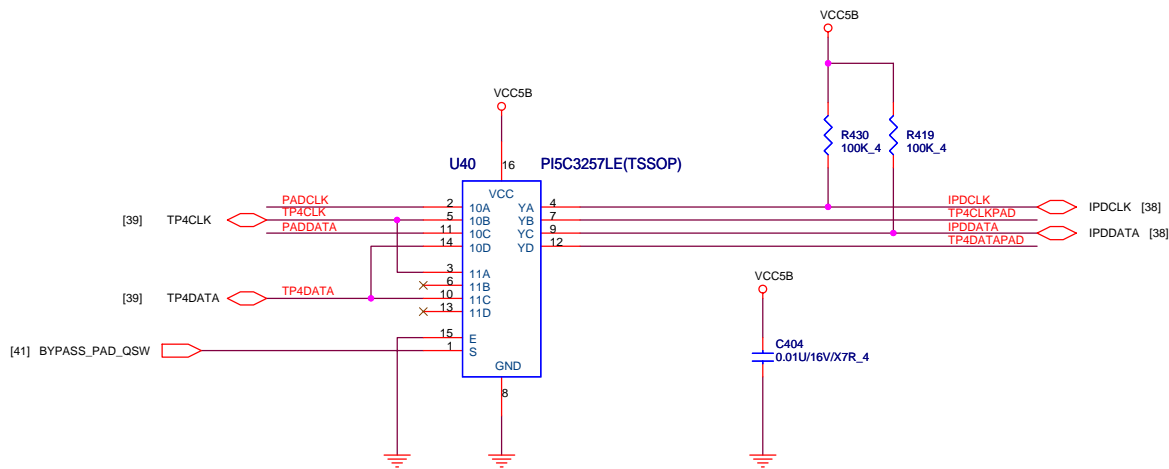
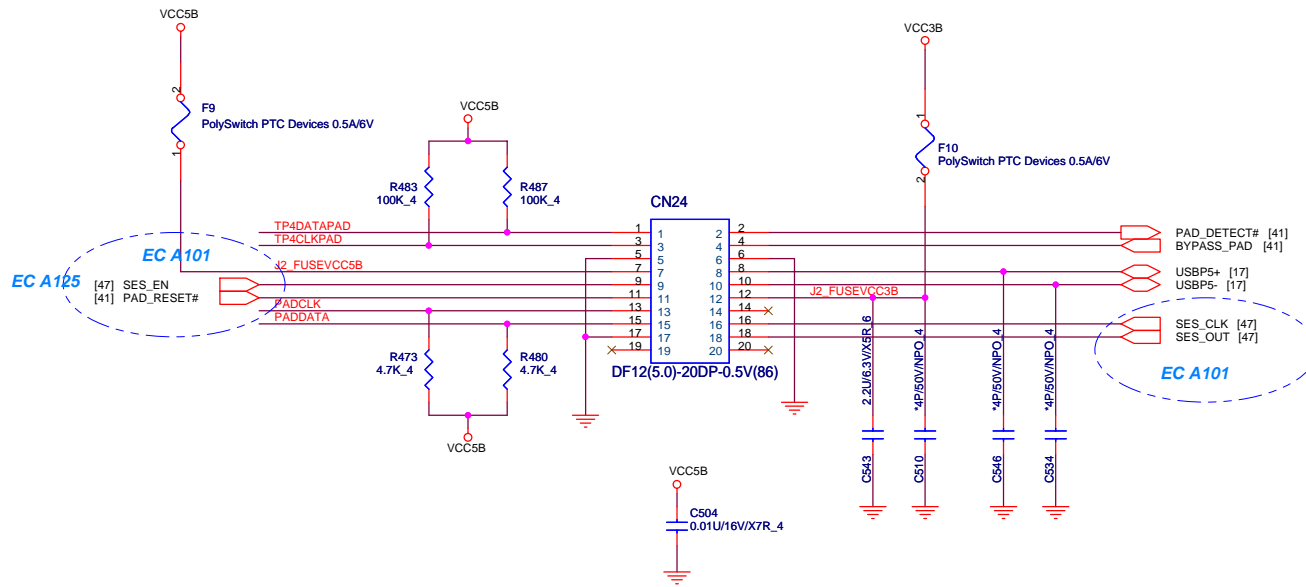



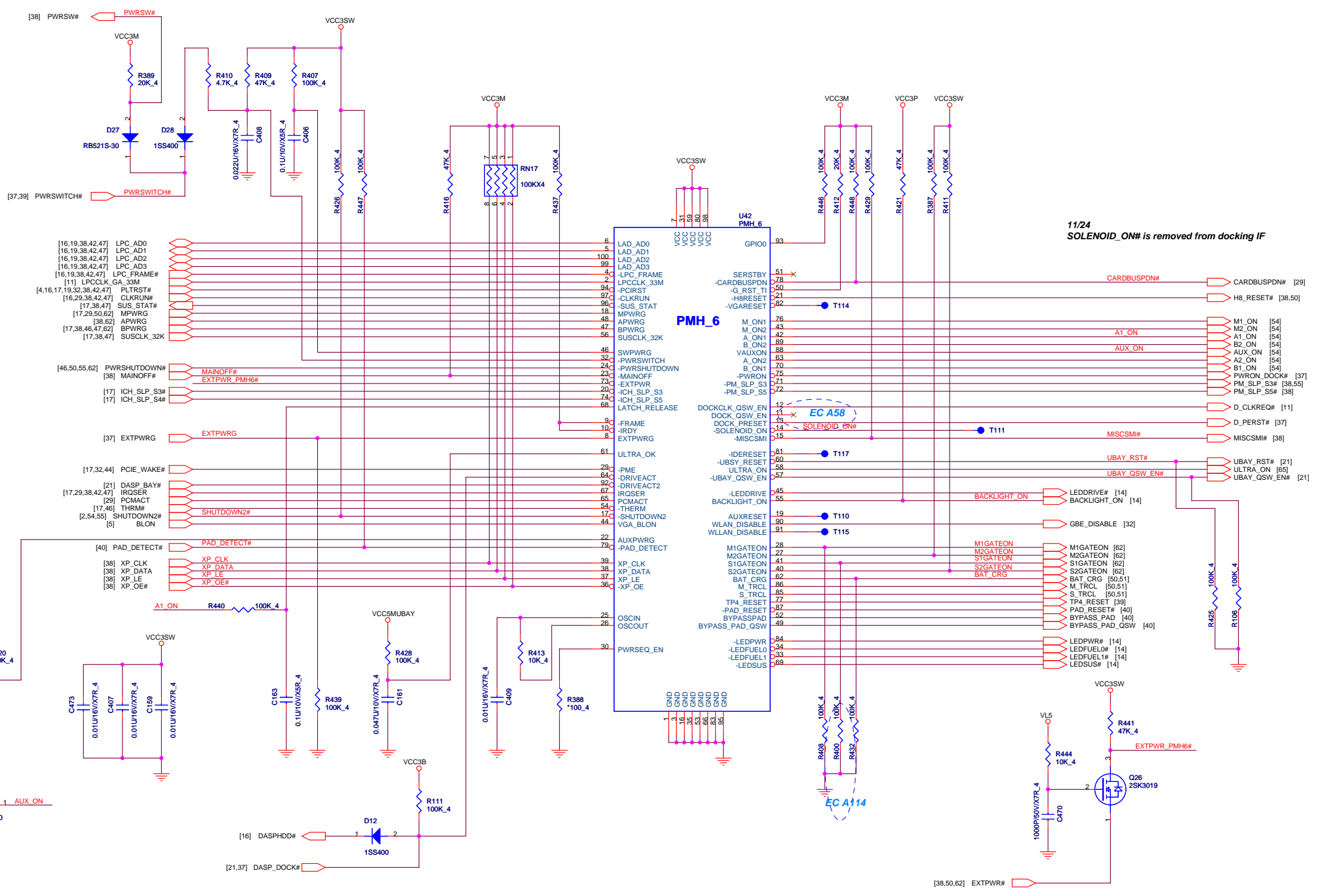

11/24  
SOLENOID\_ON# is removed from docking IF

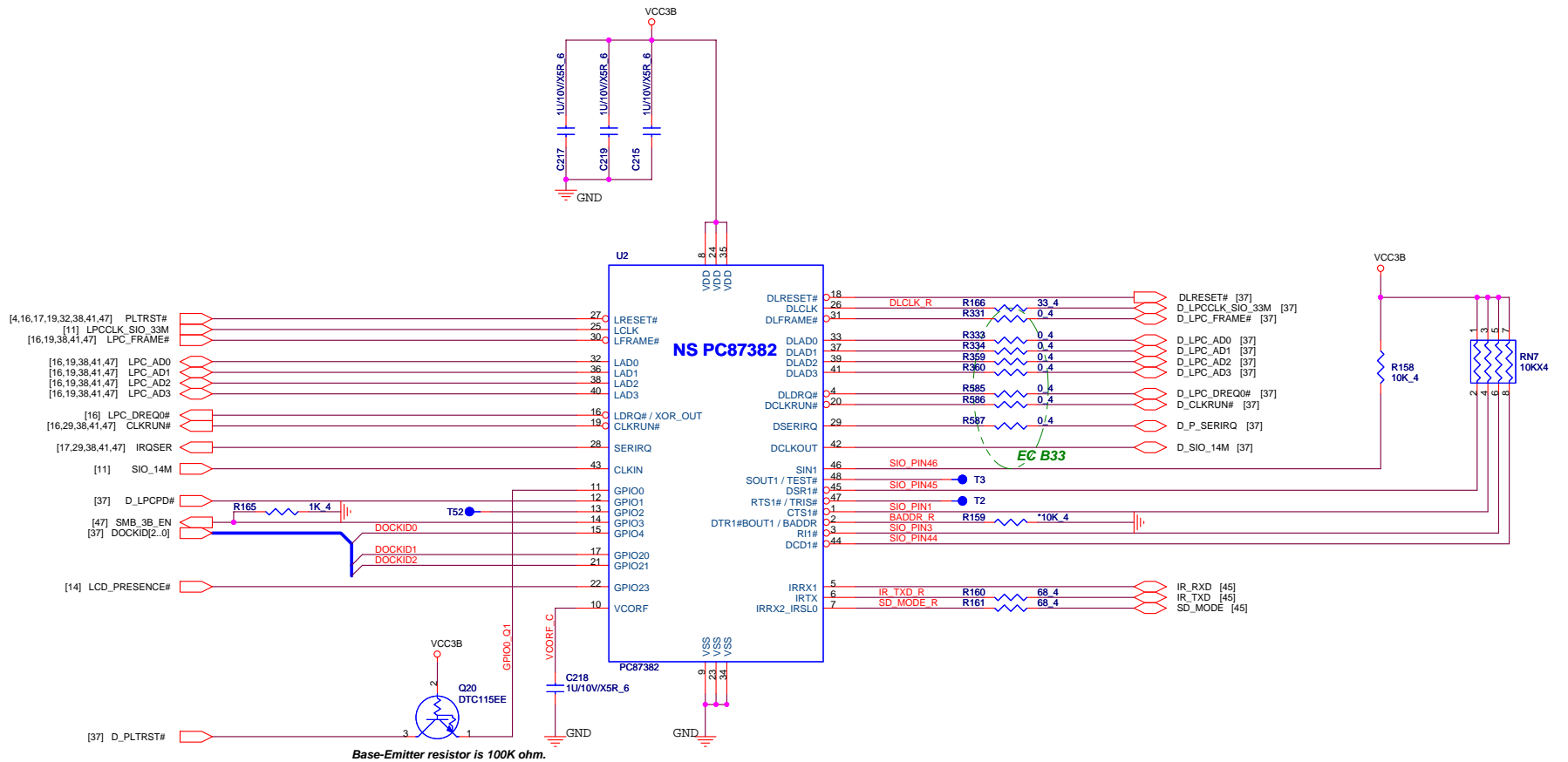

Base-Emitter resistor is 100K ohm.

 <b>PROJECT : BV1</b> <b>Quanta Computer Inc.</b>		Rev
		<b>3A</b>
Size	Document Number	Super IO
Custom		
Date:	Monday, May 09, 2005	Sheet 42 of 72

# MINI PCIE CONN-1 FOR WWAN

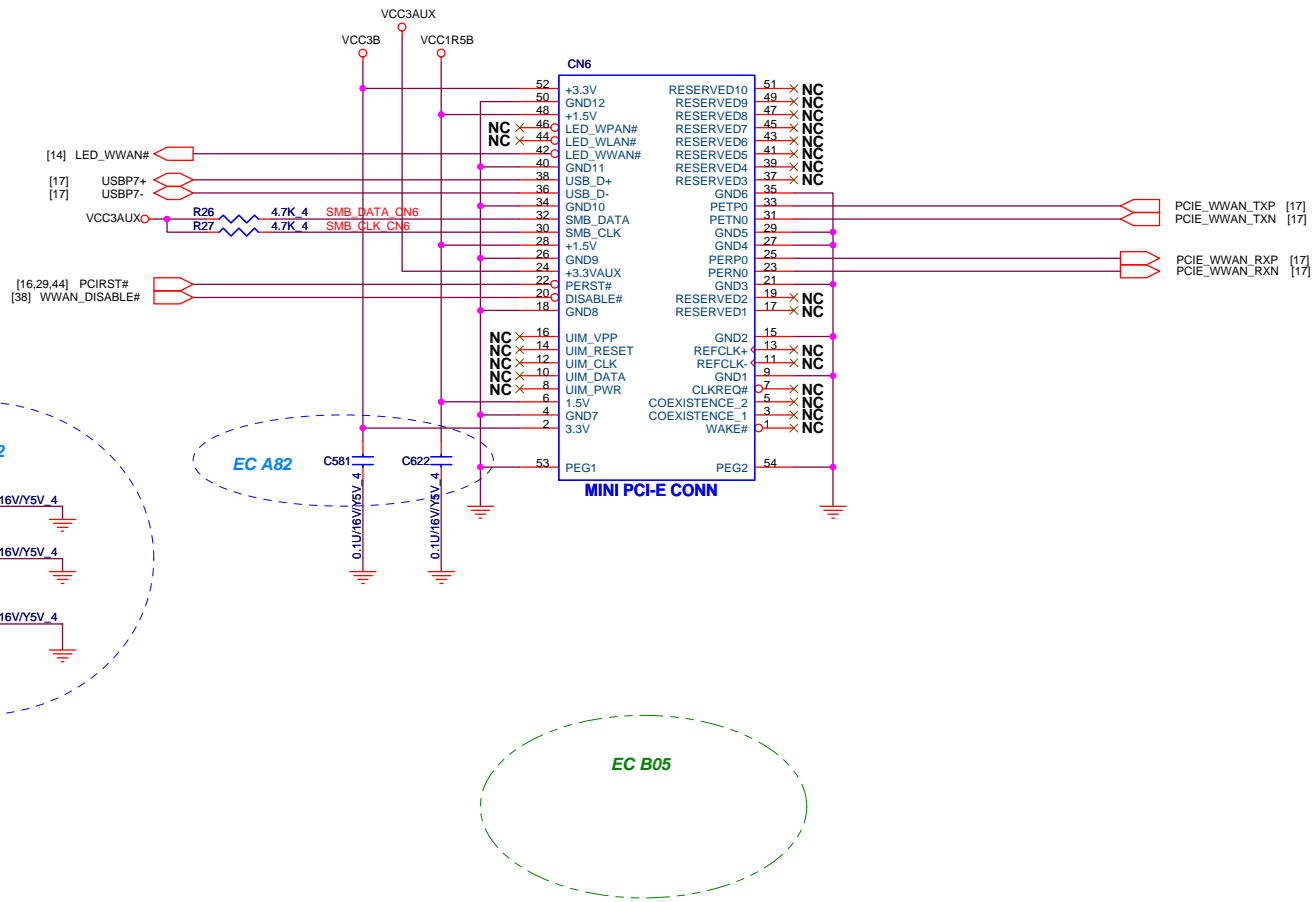

# MINI PCIE CONN-2 FOR WLAN

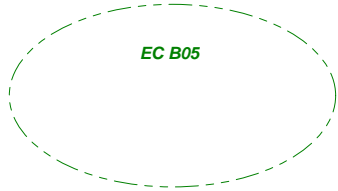
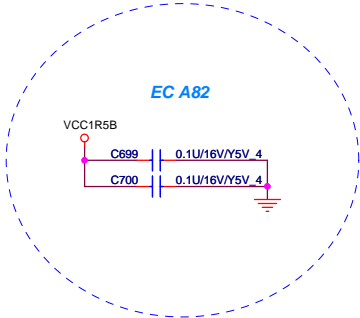
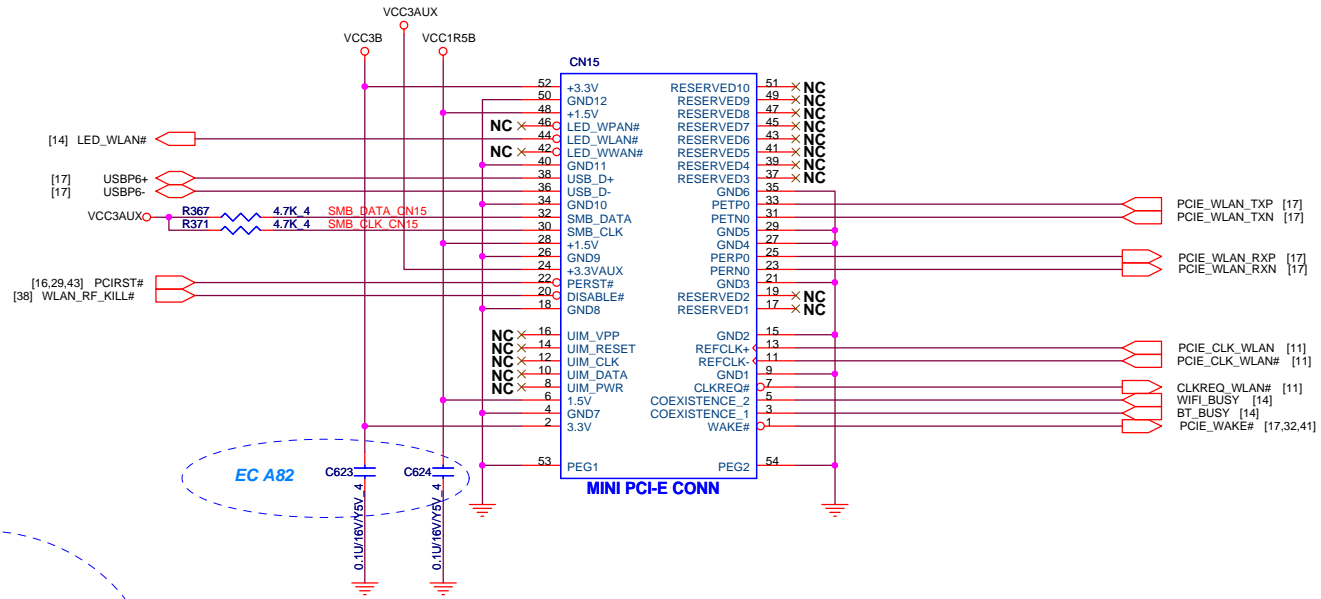

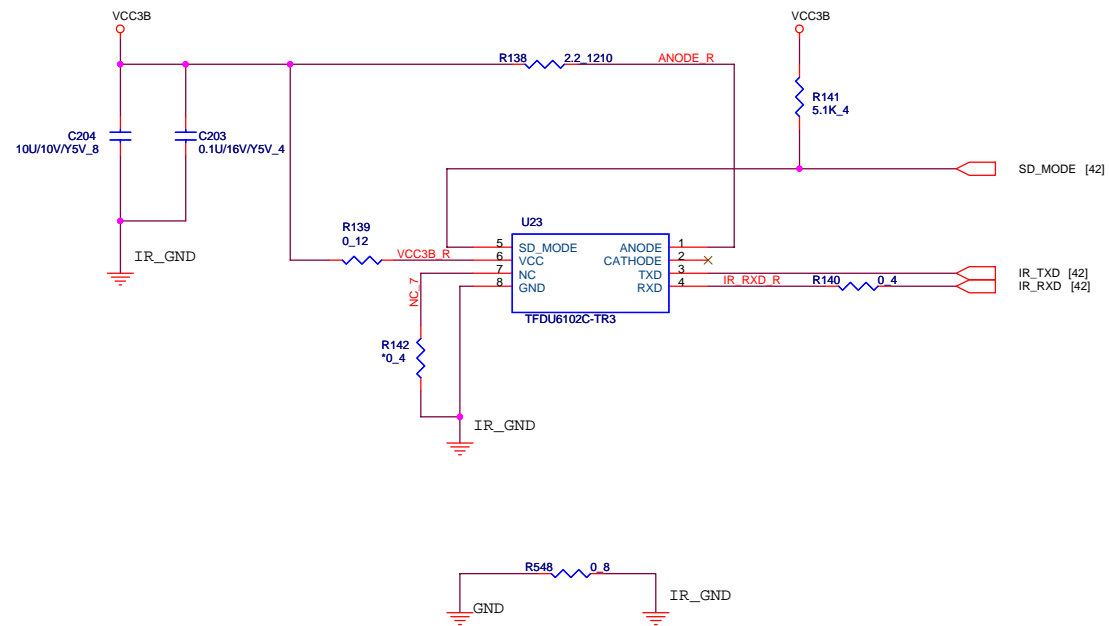

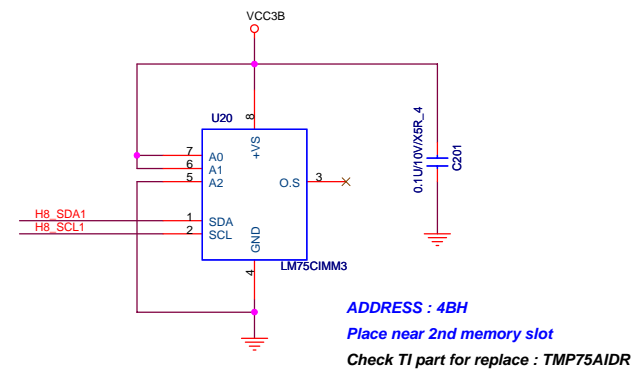
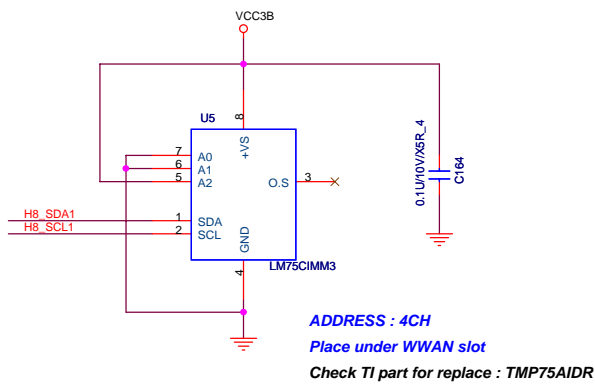
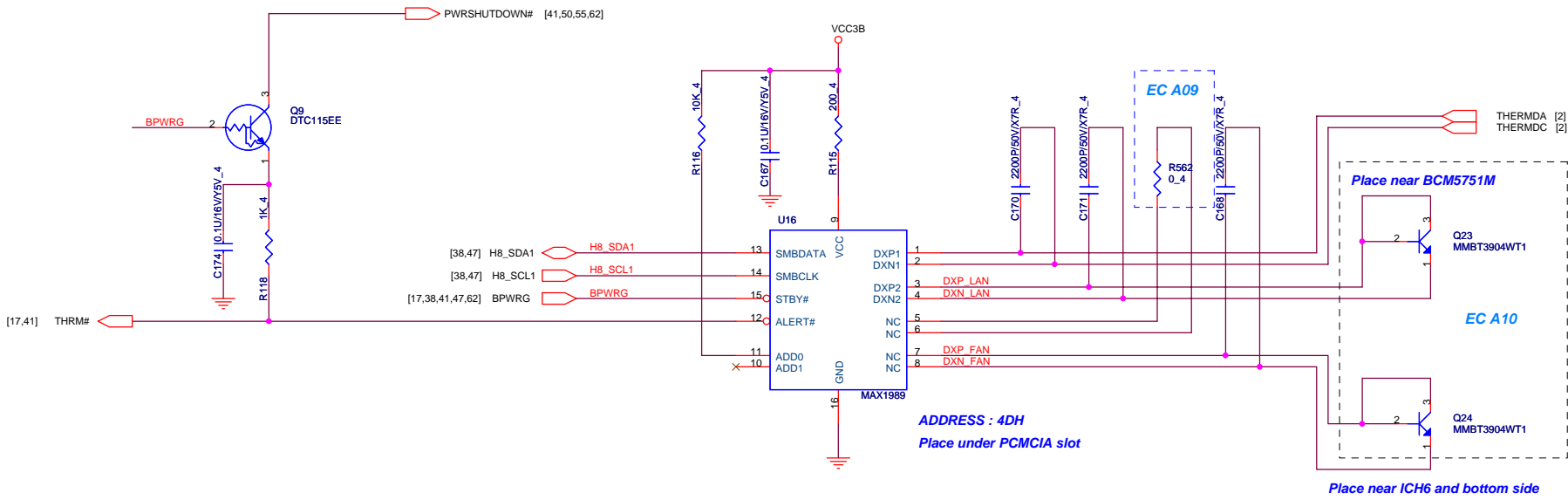

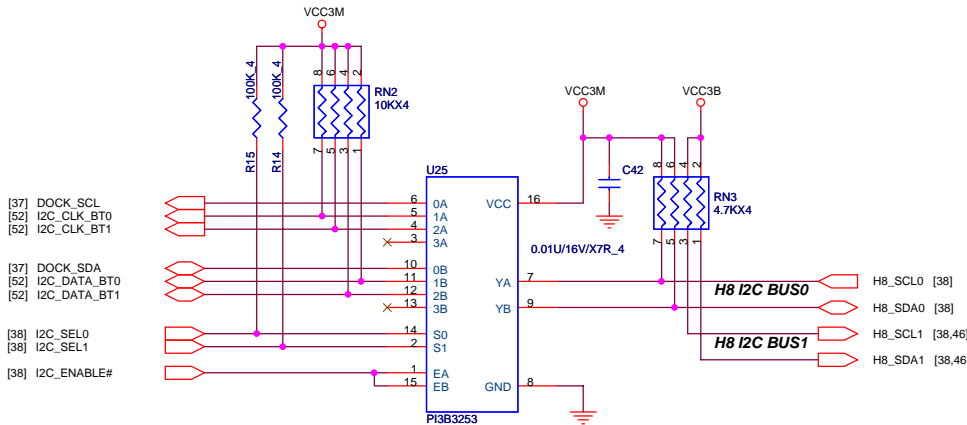

- [37] DOCK\_SCL
- [52] I2C\_CLK\_BT0
- [52] I2C\_CLK\_BT1
- [37] DOCK\_SDA
- [52] I2C\_DATA\_BT0
- [52] I2C\_DATA\_BT1
- [38] I2C\_SEL0
- [38] I2C\_SEL1
- [38] I2C\_ENABLE#

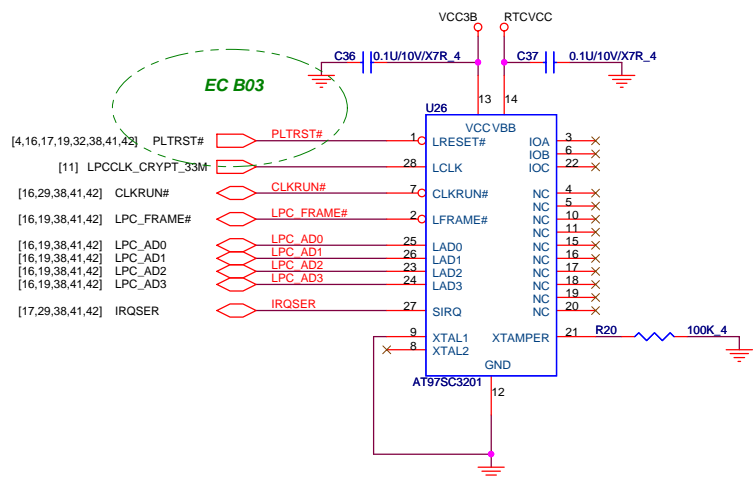

- [4,16,17,19,32,38,41,42] PLTRST#
- [11] LPCCCLK\_CRYPT\_33M
- [16,29,38,41,42] CLKRUN#
- [16,19,38,41,42] LPC\_FRAME#
- [16,19,38,41,42] LPC\_ADO
- [16,19,38,41,42] LPC\_AD1
- [16,19,38,41,42] LPC\_AD2
- [16,19,38,41,42] LPC\_AD3
- [17,29,38,41,42] IRQSER

**TCPA TABLE**

	YES	NO
U26	ASM	NO_ASM
C36	ASM	NO_ASM
C37	ASM	NO_ASM
R544	ASM	NO_ASM
R545	NO_ASM	ASM

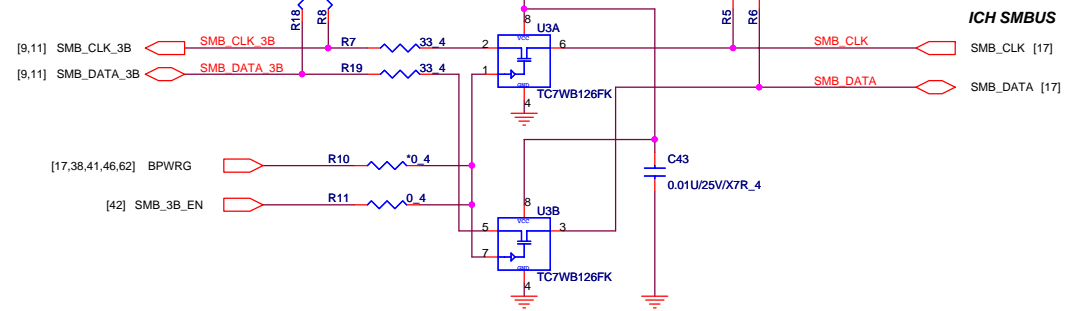
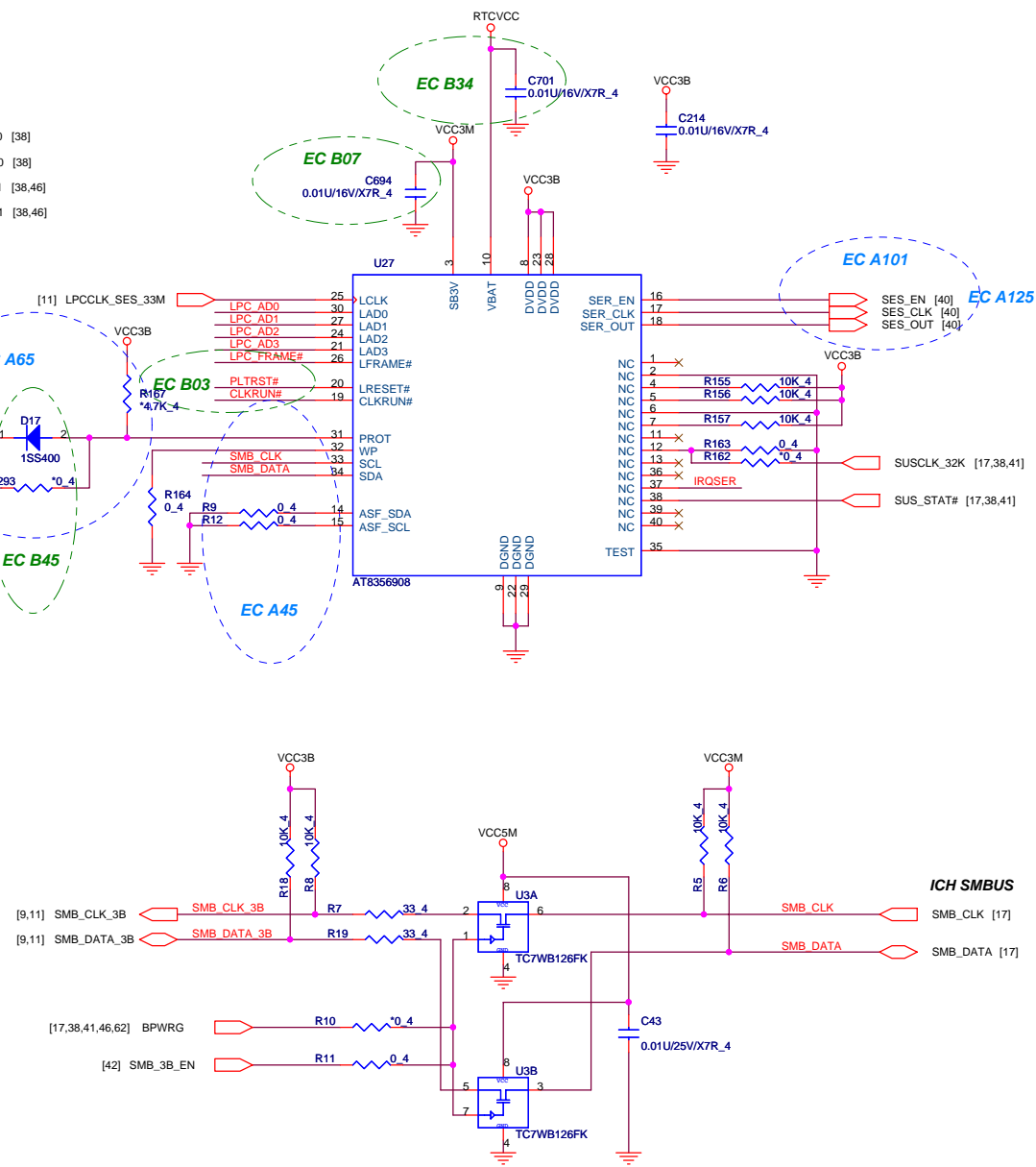

- [9,11] SMB\_CLK\_3B
- [9,11] SMB\_DATA\_3B
- [17,38,41,46,62] BPWRG
- [42] SMB\_3B\_EN

**PROJECT : BV1**  
**Quanta Computer Inc.**

Size Custom	Document Number <b>TPM</b>	Rev <b>3A</b>
Date: Thursday, May 12, 2005	Sheet 47 of 72	

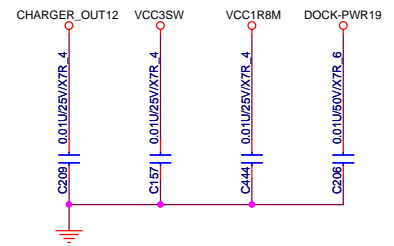
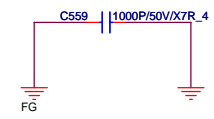
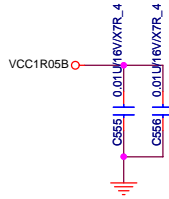
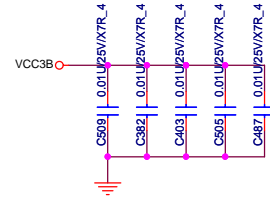
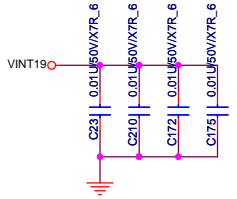
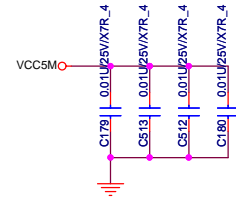
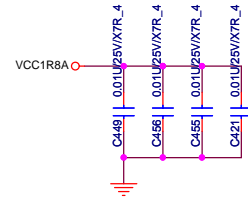
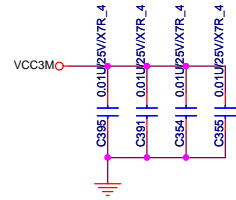
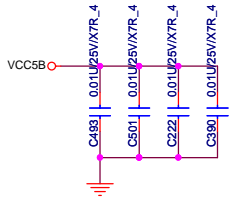
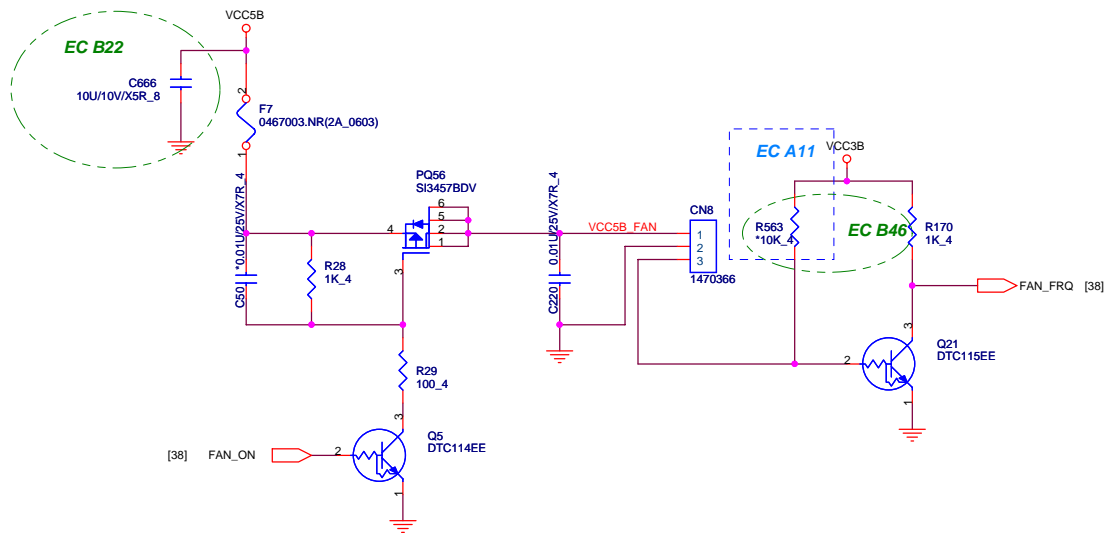

		<b>PROJECT : BV1</b> <b>Quanta Computer Inc.</b>	
		Size Custom Document Number <b>FAN Control_EMC</b>	Rev <b>3A</b>
Date: Thursday, May 12, 2005		Sheet 48 of 72	



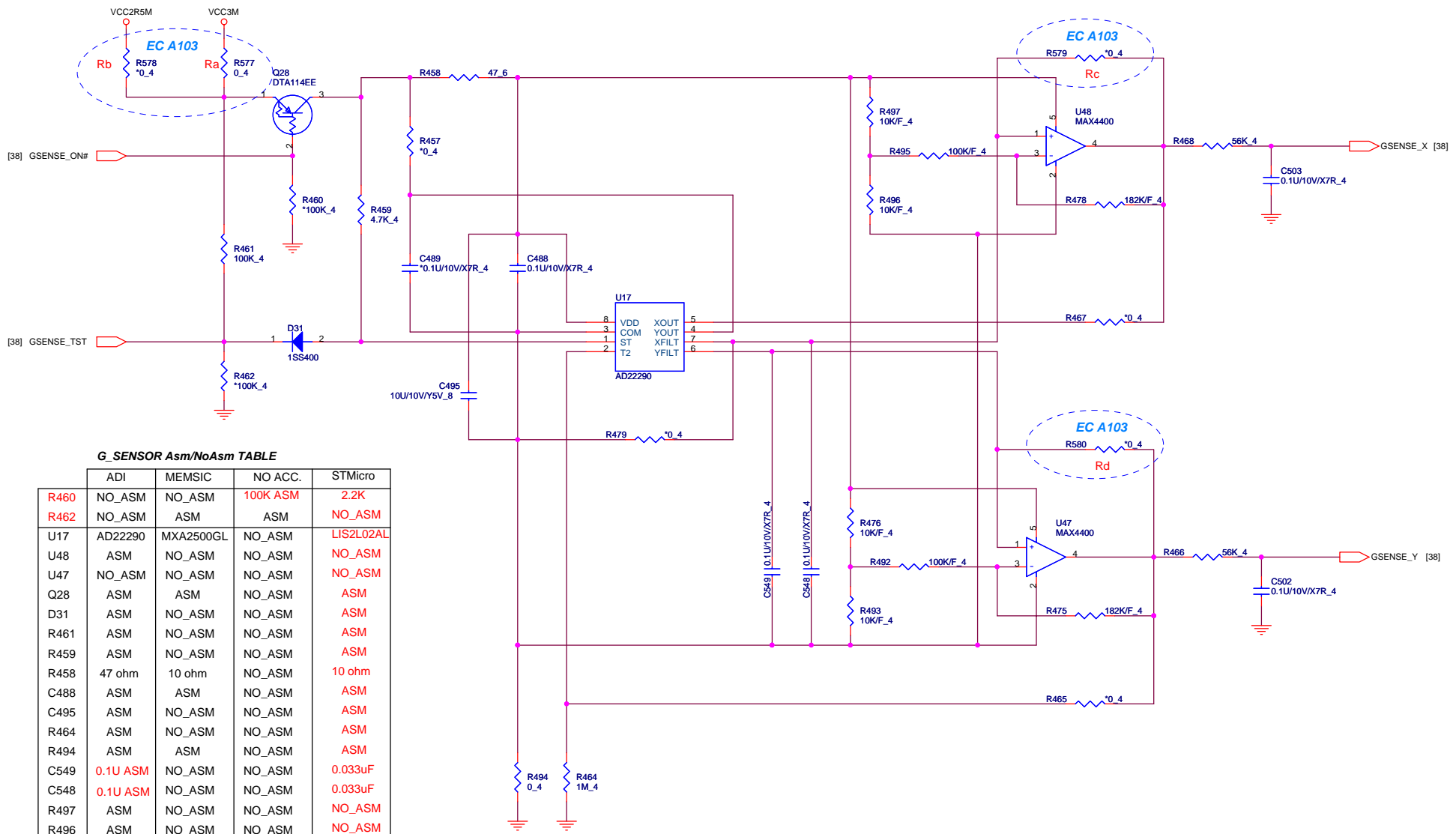

G\_SENSOR Asm/NoAsm TABLE

	ADI	MEMSIC	NO ACC.	STMicro
R460	NO_ASM	NO_ASM	100K ASM	2.2K
R462	NO_ASM	ASM	ASM	NO_ASM
U17	AD22290	MXA2500GL	NO_ASM	LIS2L02AL
U48	ASM	NO_ASM	NO_ASM	NO_ASM
U47	NO_ASM	NO_ASM	NO_ASM	NO_ASM
Q28	ASM	ASM	NO_ASM	ASM
D31	ASM	NO_ASM	NO_ASM	ASM
R461	ASM	NO_ASM	NO_ASM	ASM
R459	ASM	NO_ASM	NO_ASM	ASM
R458	47 ohm	10 ohm	NO_ASM	10 ohm
C488	ASM	ASM	NO_ASM	ASM
C495	ASM	NO_ASM	NO_ASM	ASM
R464	ASM	NO_ASM	NO_ASM	ASM
R494	ASM	ASM	NO_ASM	ASM
C549	0.1U ASM	NO_ASM	NO_ASM	0.033uF
C548	0.1U ASM	NO_ASM	NO_ASM	0.033uF
R497	ASM	NO_ASM	NO_ASM	NO_ASM
R496	ASM	NO_ASM	NO_ASM	NO_ASM
R495	ASM	NO_ASM	NO_ASM	NO_ASM
R478	ASM	NO_ASM	NO_ASM	NO_ASM
R476	ASM	NO_ASM	NO_ASM	NO_ASM
R493	ASM	NO_ASM	NO_ASM	NO_ASM
R492	ASM	NO_ASM	NO_ASM	NO_ASM
R475	ASM	NO_ASM	NO_ASM	NO_ASM
R468	56K	8.2K	NO_ASM	56K
C503	ASM	ASM	NO_ASM	ASM
R466	56K	8.2K	NO_ASM	56K
C502	ASM	ASM	NO_ASM	ASM
R457	NO_ASM	ASM	NO_ASM	NO_ASM
C489	NO_ASM	ASM	NO_ASM	NO_ASM
R479	NO_ASM	ASM	NO_ASM	NO_ASM
R467	NO_ASM	ASM	NO_ASM	NO_ASM
R465	NO_ASM	ASM	NO_ASM	NO_ASM

EC B41

	ADI	MEMSIC	STMicro	NO ACC.
Ra	ASM	ASM	ASM	NO_ASM
Rb	NO_ASM	NO_ASM	NO_ASM	NO_ASM
Rc	NO_ASM	NO_ASM	ASM	NO_ASM
Rd	NO_ASM	NO_ASM	ASM	NO_ASM

**PROJECT : BV1**  
**Quanta Computer Inc.**

Size Custom | Document Number | G-Sensor | Rev 3A

Date: Monday, May 09, 2005 | Sheet 49 of 72



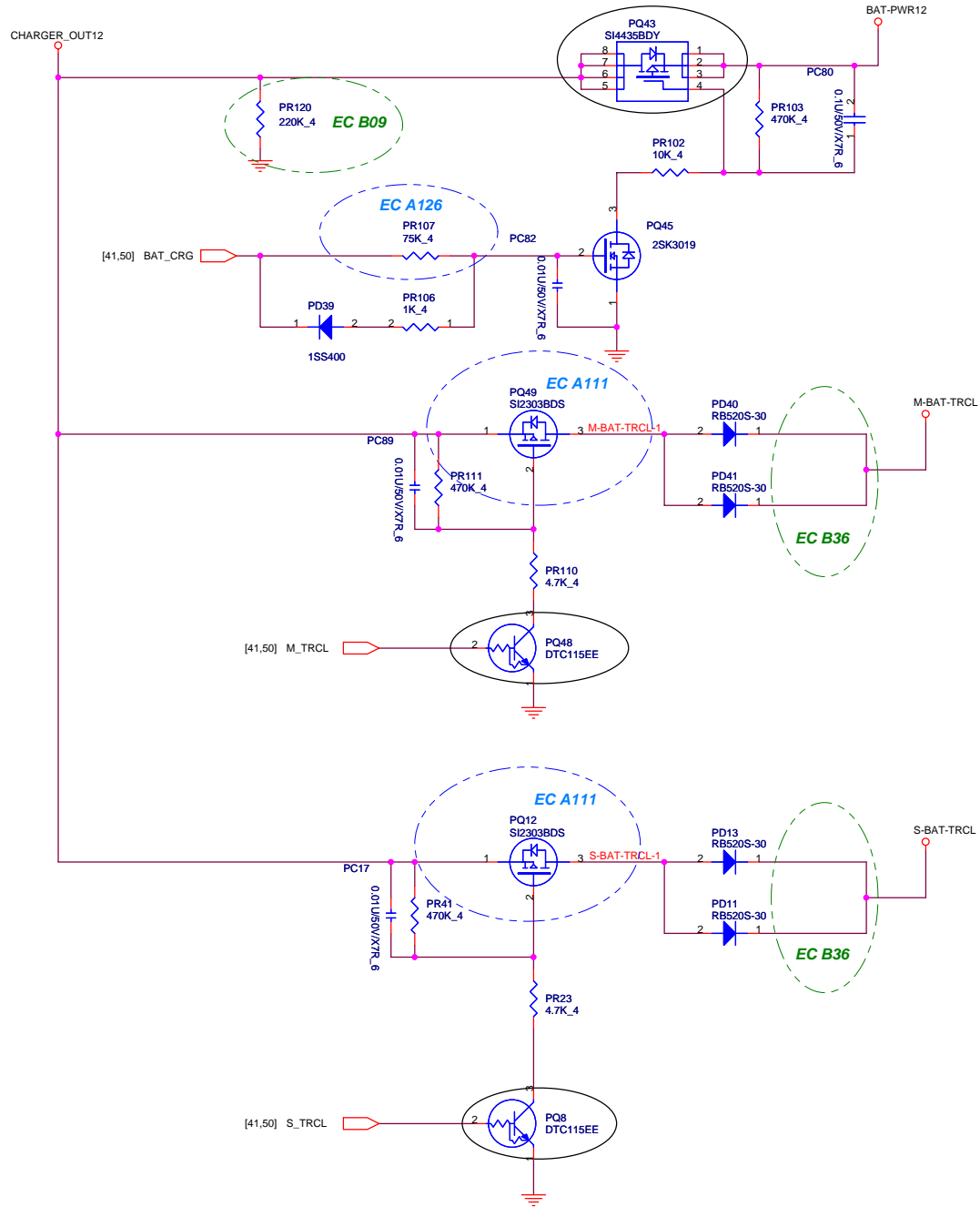

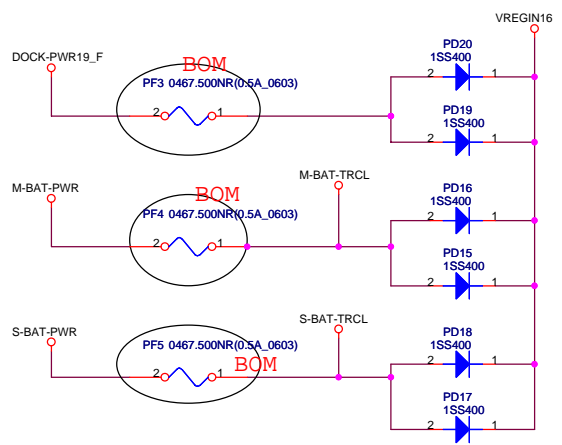
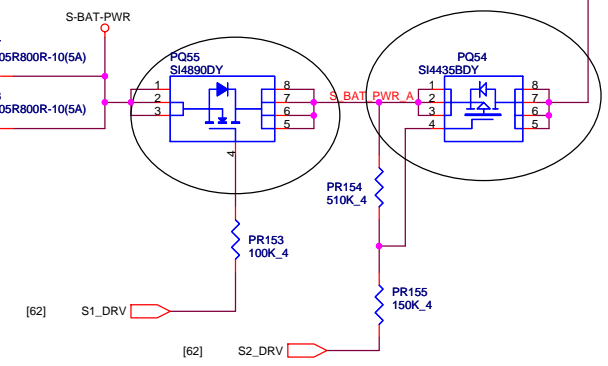
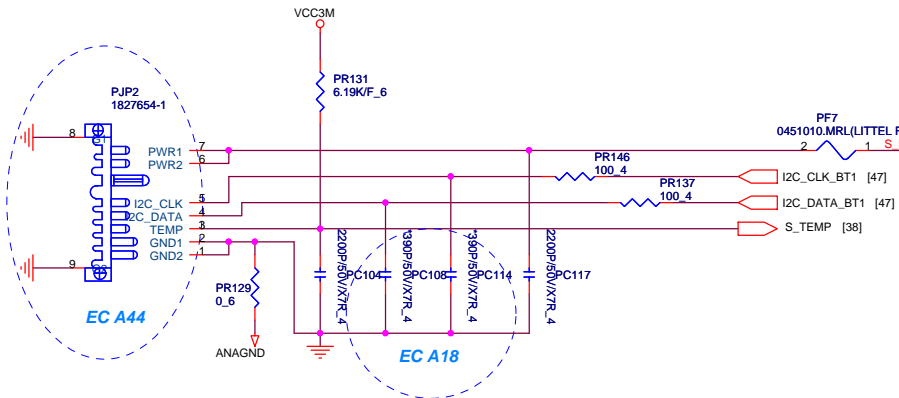
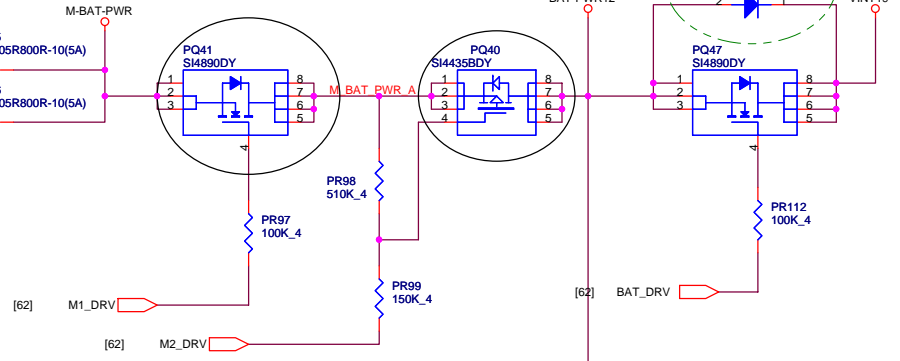
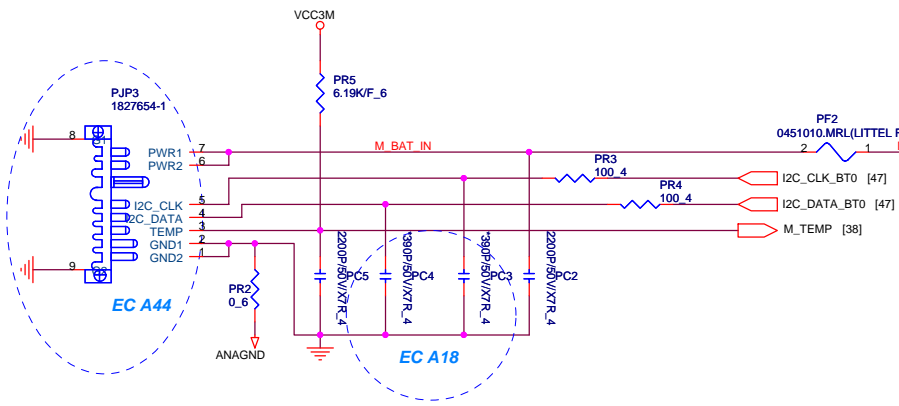

 <b>PROJECT : BV1</b> <b>Quanta Computer Inc.</b>		Rev
Size	Document Number	Battery Input
Custom		
Date:	Monday, May 09, 2005	Sheet 52 of 72

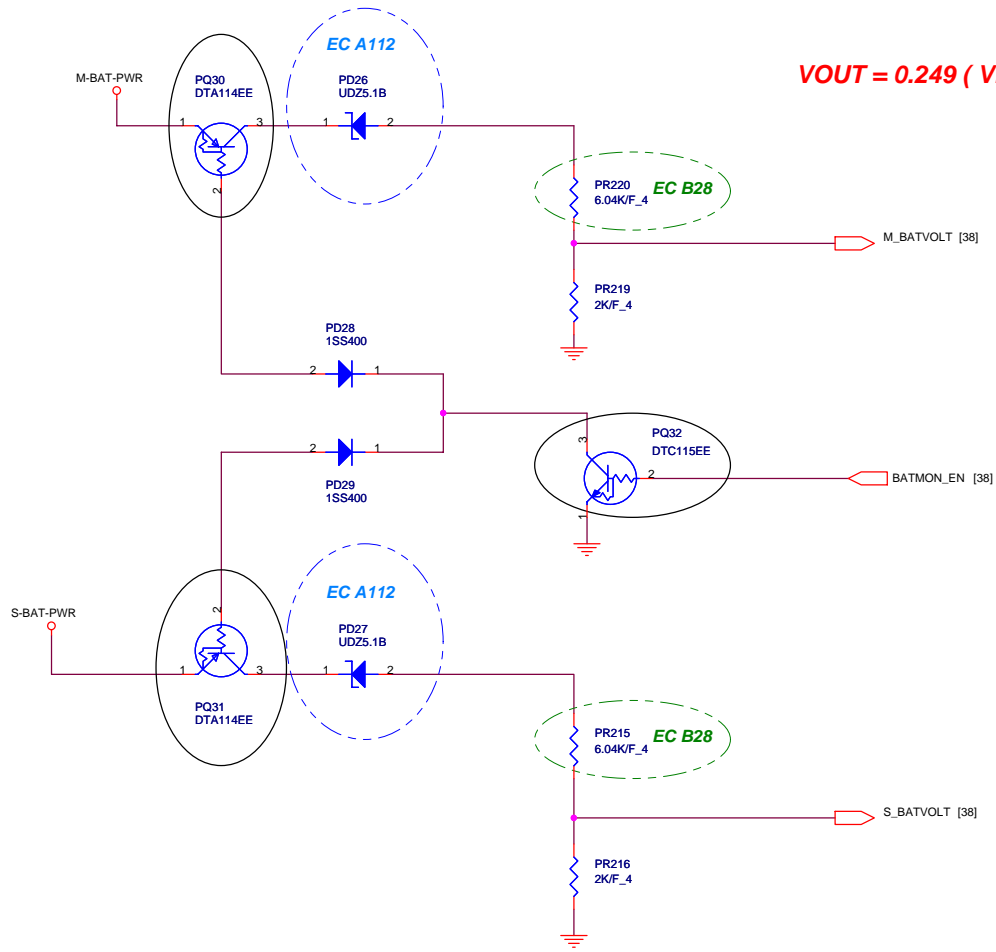

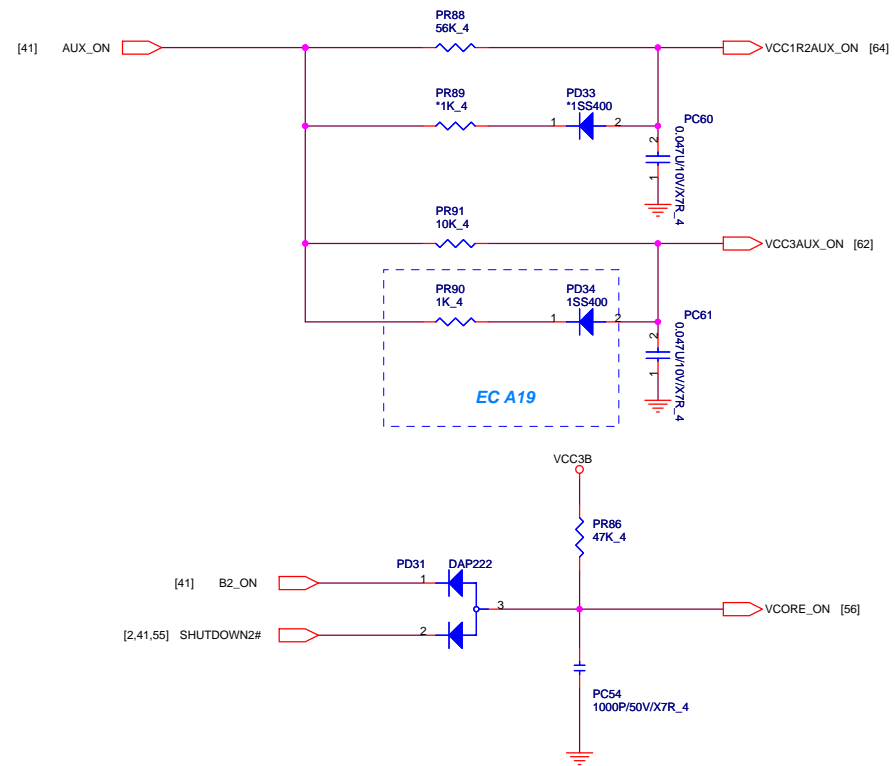
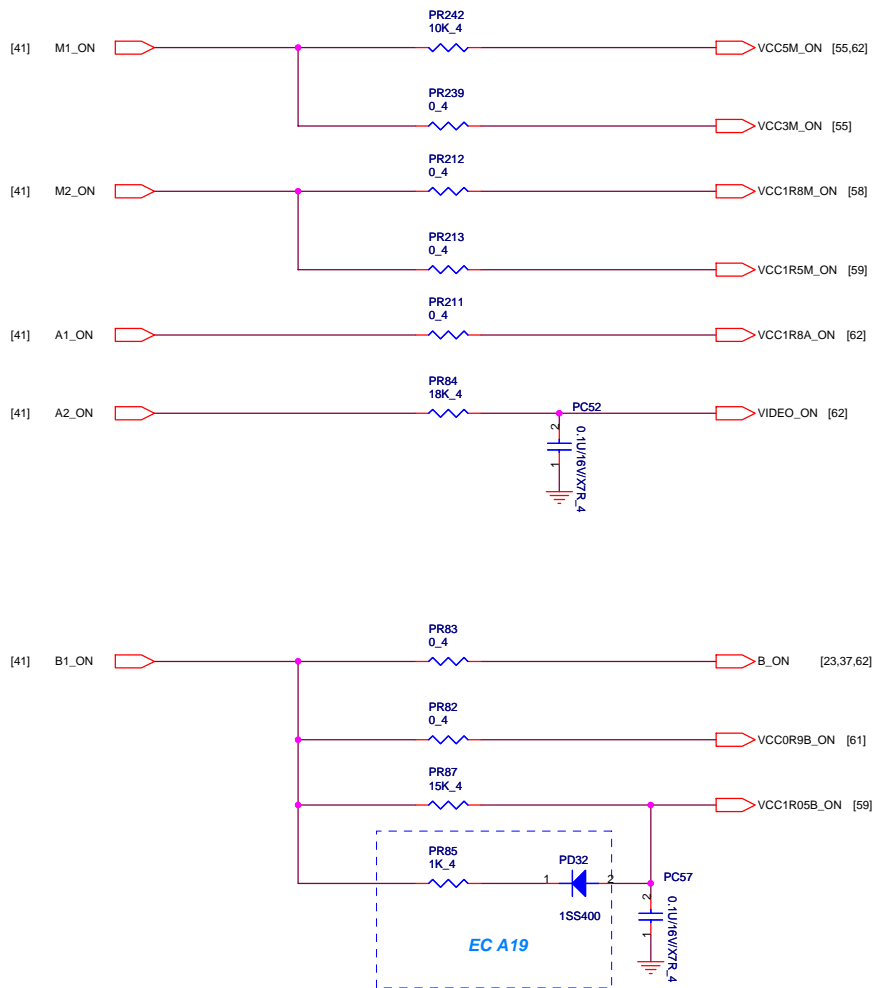

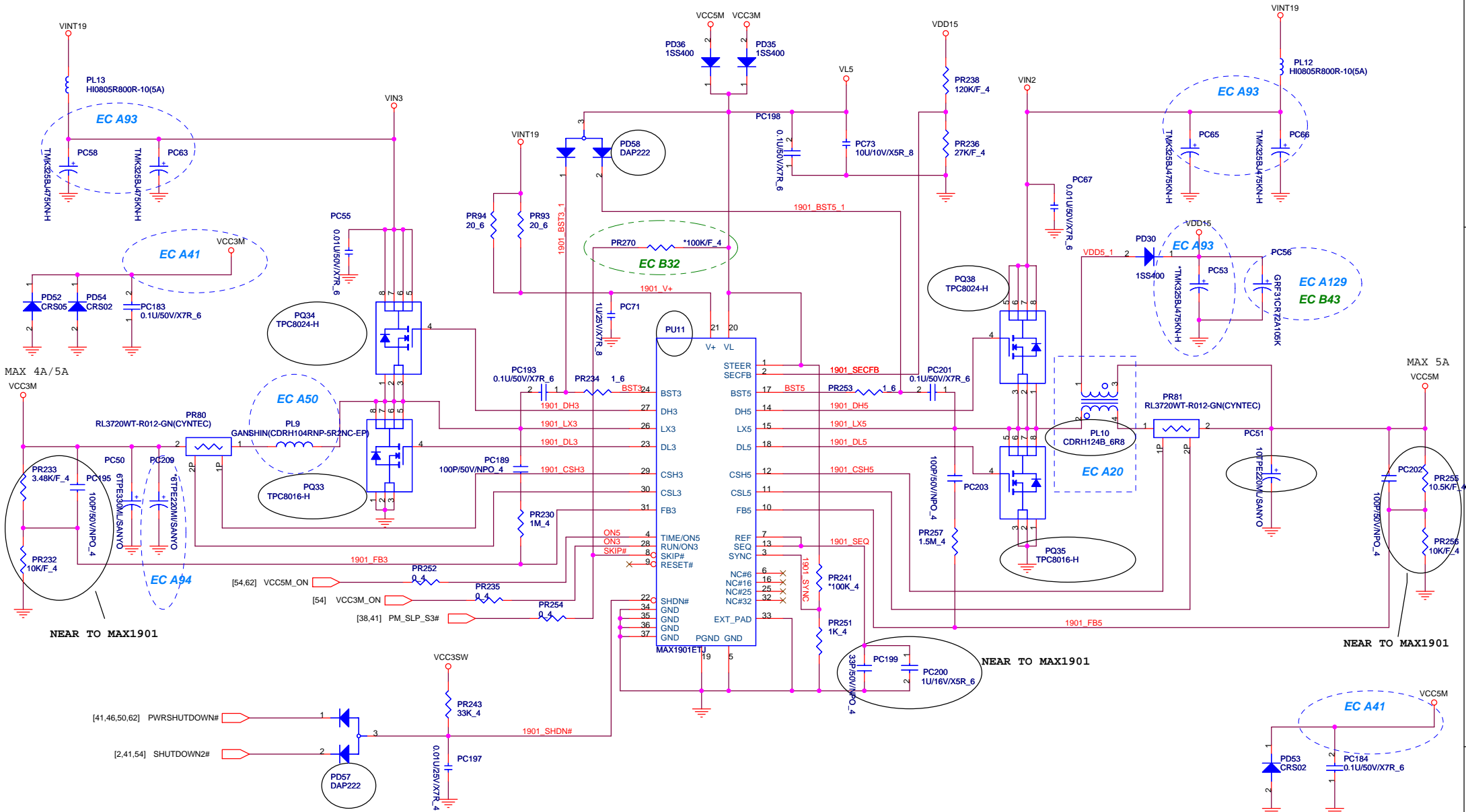

NEAR TO MAX1901

NEAR TO MAX1901

NEAR TO MAX1901

 <b>PROJECT : BV1</b> <b>Quanta Computer Inc.</b>		Rev
		<b>3A</b>
Size	Document Number	Date:
A3	<b>DC/DC 3V/5V</b>	Monday, May 09, 2005
Sheet		of
55		72

Intel spec. : Vos% = 1.2%  
 $PR103 / (PR102 + PR103) = 1.21K / (100K + 1.21K) \sim 1.2\%$   
 $PR105 : 200K \text{ Ohms} \rightarrow Fsw \sim 300K \text{ HZ}$

PWRCH : "H" -----> Two phase  
 PWRCH : "L" -----> Single phase

	DSEN#	DRSEN
Active	H	L
Deep	L	L
Deeper	L	H

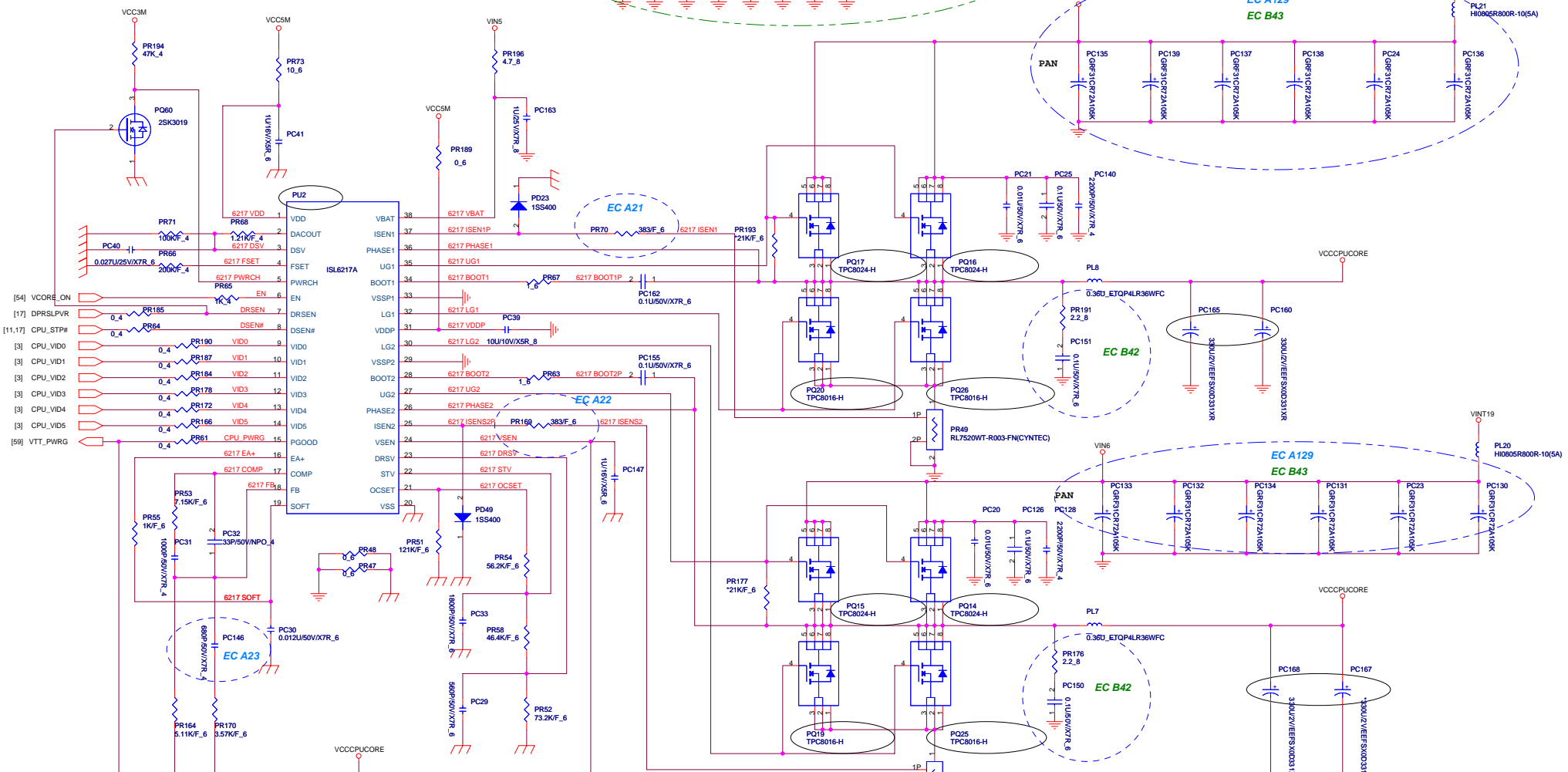

$PC109 = I_{source} / SR = 130\mu A / (10mV/\mu s) = 13nF$   
 $PR131 = (3.3V - 0.05 * 3.3V) / 2mA - 82 \text{ Ohms} = 1.48K \text{ Ohms}$

Intel spec.  
 Deeper sleep voltage : 0.726V  
 Start up voltage : 1.2V  
 $V_{ocset} = 1.75V$   
 Deeper sleep vol. =  $1.75V * PR129 / (PR124 + PR126 + PR129) = 0.749V$   
 Start up voltage =  $1.75V * (PR126 + PR129) / (PR124 + PR126 + PR129) = 1.2V$

If full load is 25A ;  $V_{droop} = 75mV$  ;  $I_{droop} = 75mV / PR107 = 75\mu A$   
 $I_{sen} = (75\mu A / 0.5 / 0.875) / 2 = 85.71\mu A$   
 $85.71\mu A * (R_{sen} + 0.11K) = (25A / 2) * 3m \text{ Ohms}$   
 $R_{sen} = 327.5 \sim 324 \text{ Ohms} \rightarrow PR104, PR118$

If Ioc is 32A  
 $I_{sen} = (32A / 2) * 3m / (0.324K + 0.11K) = 110.6\mu A$   
 $I_{ocset} = (110.6\mu A * 2) * 0.875 / 8 = 24.2\mu A$   
 $R_{ocset} = 1.75V / 24.2\mu A = 72.3K$

$R_{ocset} = PR122 / (PR124 + PR126 + PR129)$   
 $72.3K = PR122 / (175.2K)$   
 $PR122 \sim 121K$

**Set VID voltage**

VID						OUTPUT
VID_5	VID_4	VID_3	VID_2	VID_1	VID_0	VOLTAGE
0	1	0	1	1	0	1.356
0	1	0	1	1	1	1.340
0	1	1	0	0	0	1.324
0	1	1	0	0	1	1.308
0	1	1	0	1	0	1.292
0	1	1	0	1	1	1.276

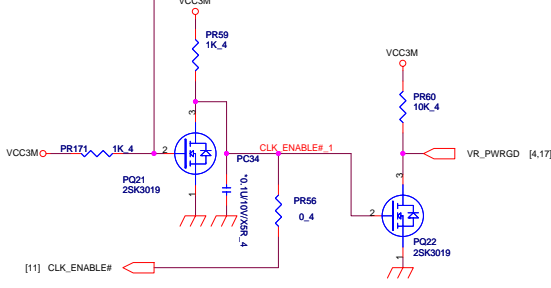



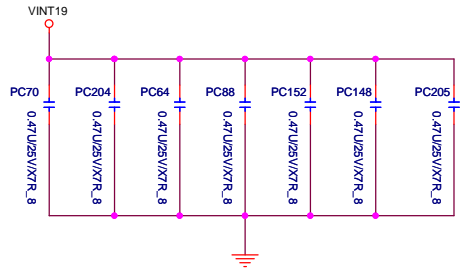

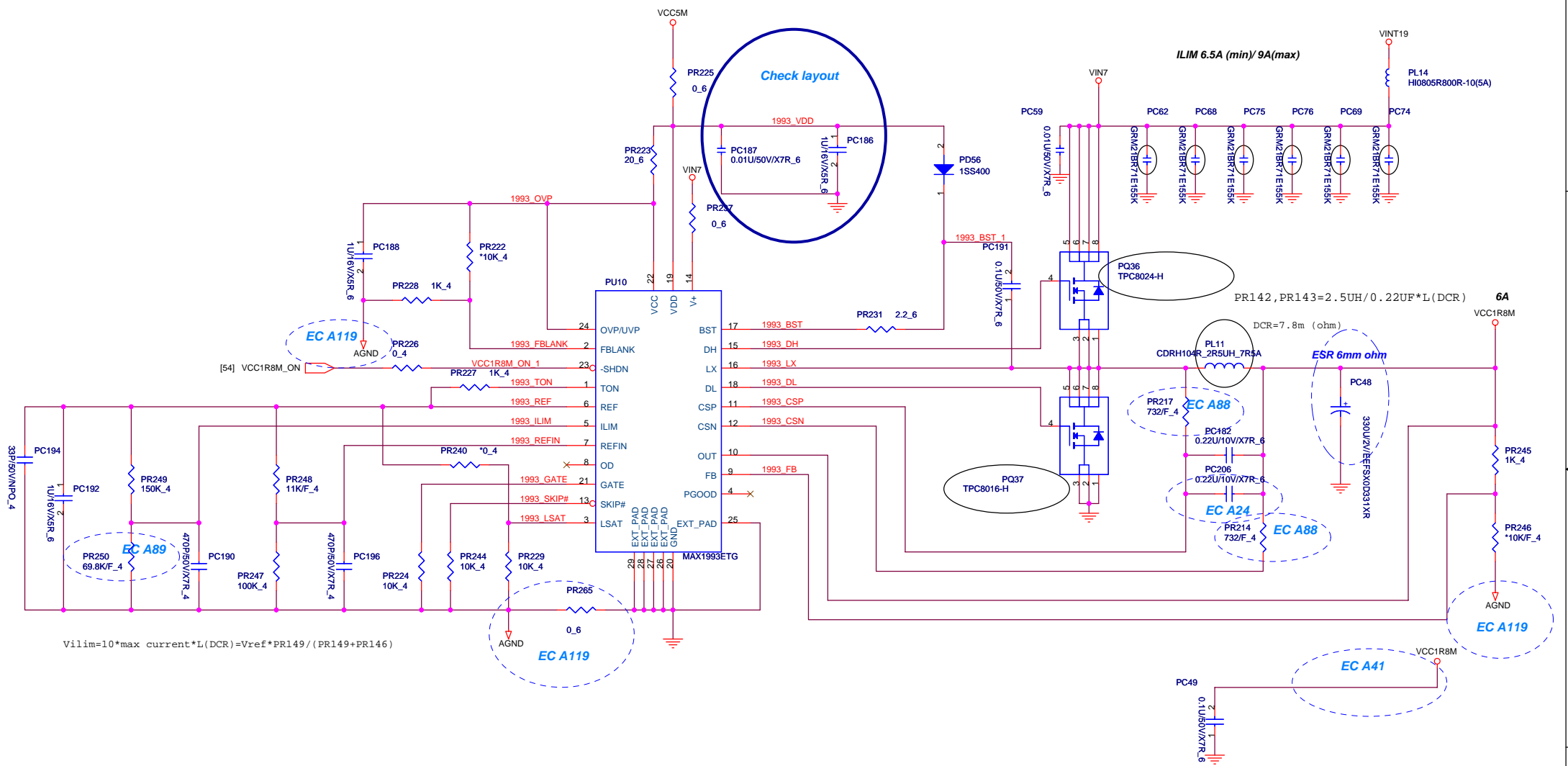

Check layout

ILIM 6.5A (min)/ 9A(max)

$$V_{ilim} = 10 * \text{max current} * L(\text{DCR}) = V_{ref} * PR149 / (PR149 + PR146)$$

ESR 6mm ohm

PR142, PR143 = 2.5UH / 0.22UF \* L(DCR)

DCR = 7.8m (ohm)

EC A41

		<b>PROJECT : BV1</b> <b>Quanta Computer Inc.</b>	
		Size A3 Document Number <b>MAX1993 1.8V</b>	Rev <b>3A</b>
Date: Monday, May 09, 2005		Sheet 58 of 72	

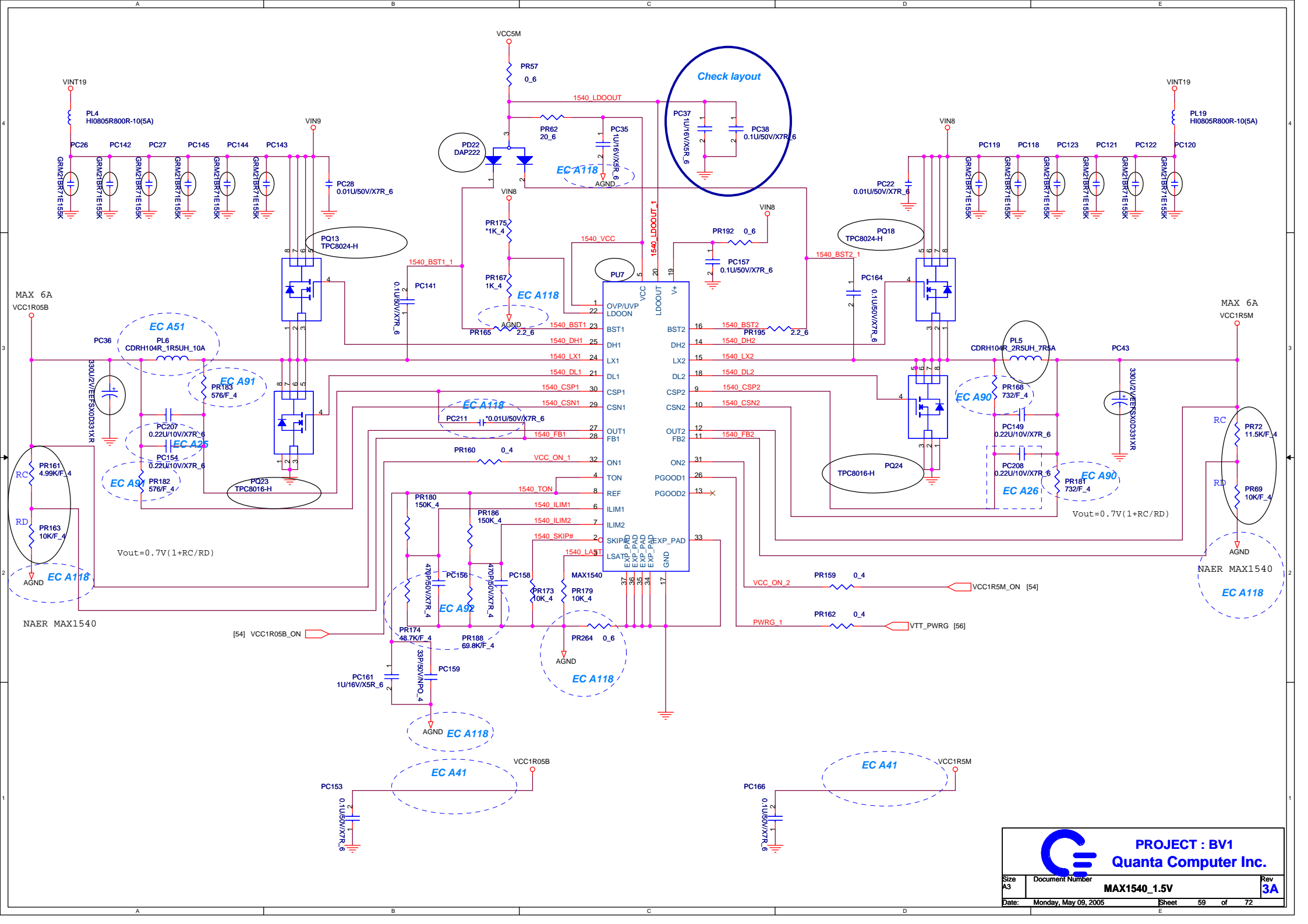

Check layout

$$V_{out} = 0.7V(1 + RC/RD)$$

$$V_{out} = 0.7V(1 + RC/RD)$$

 <b>PROJECT : BV1</b> <b>Quanta Computer Inc.</b>		Rev	3A
		Size	A3
Date:	Monday, May 09, 2005	Document Number	MAX1540_1.5V
Sheet	59	of	72

BLANK PAGE

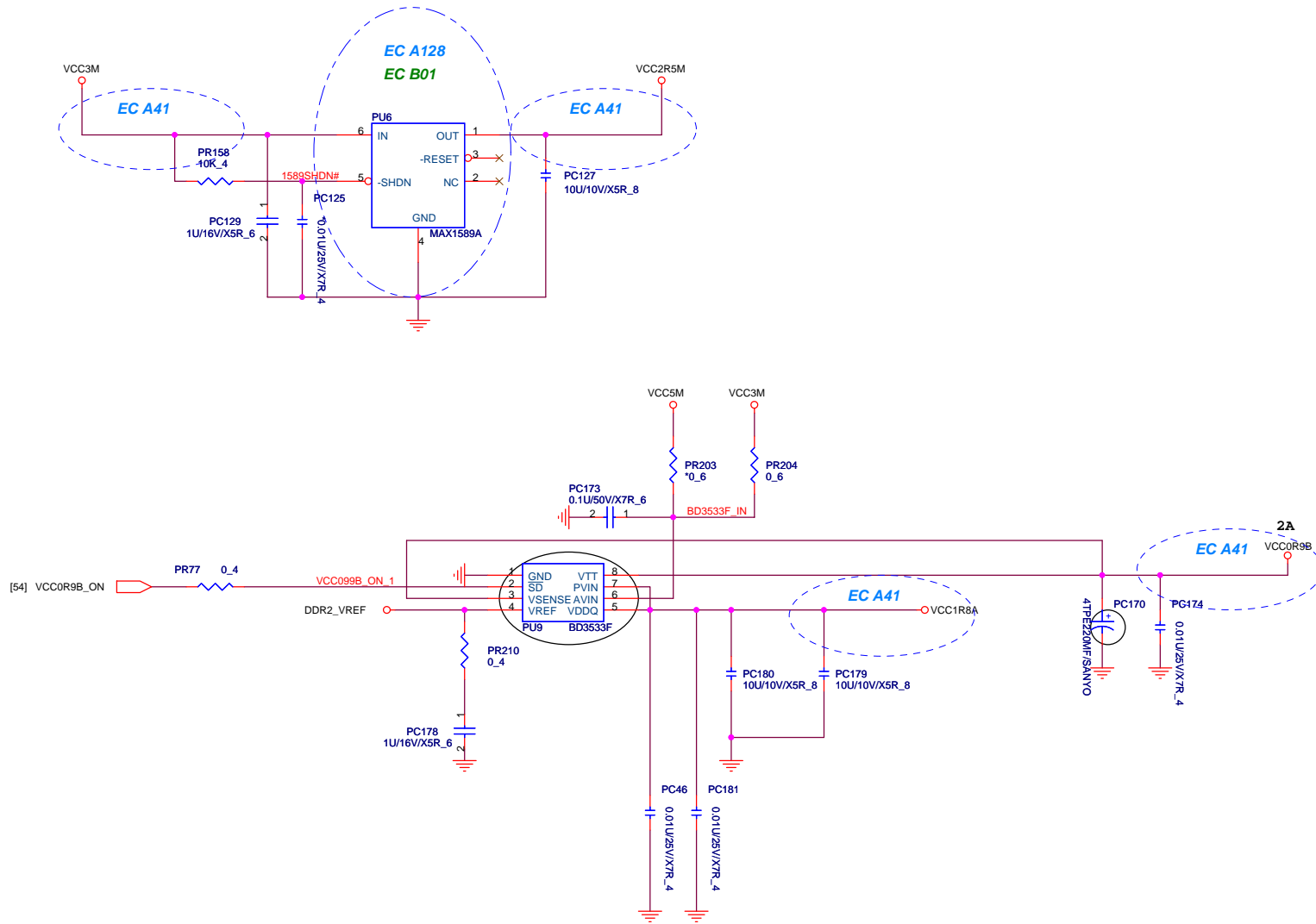





BLANK PAGE

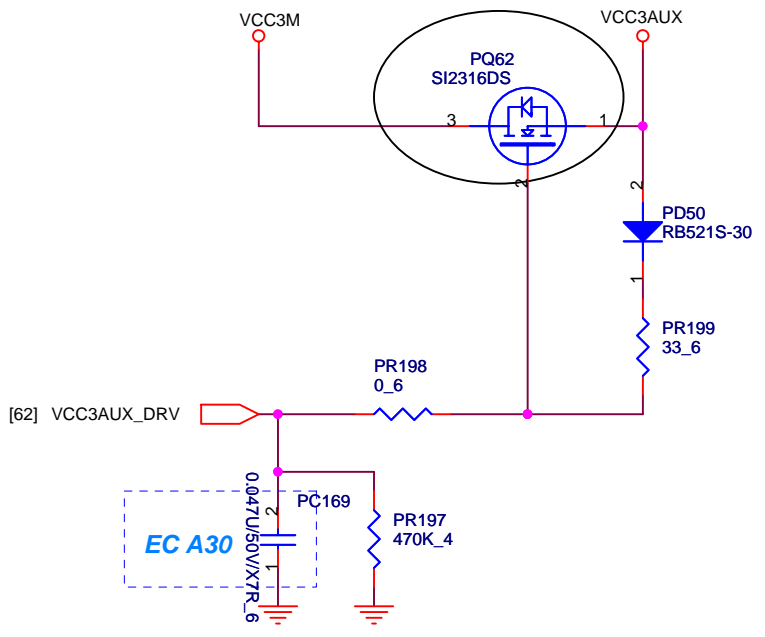
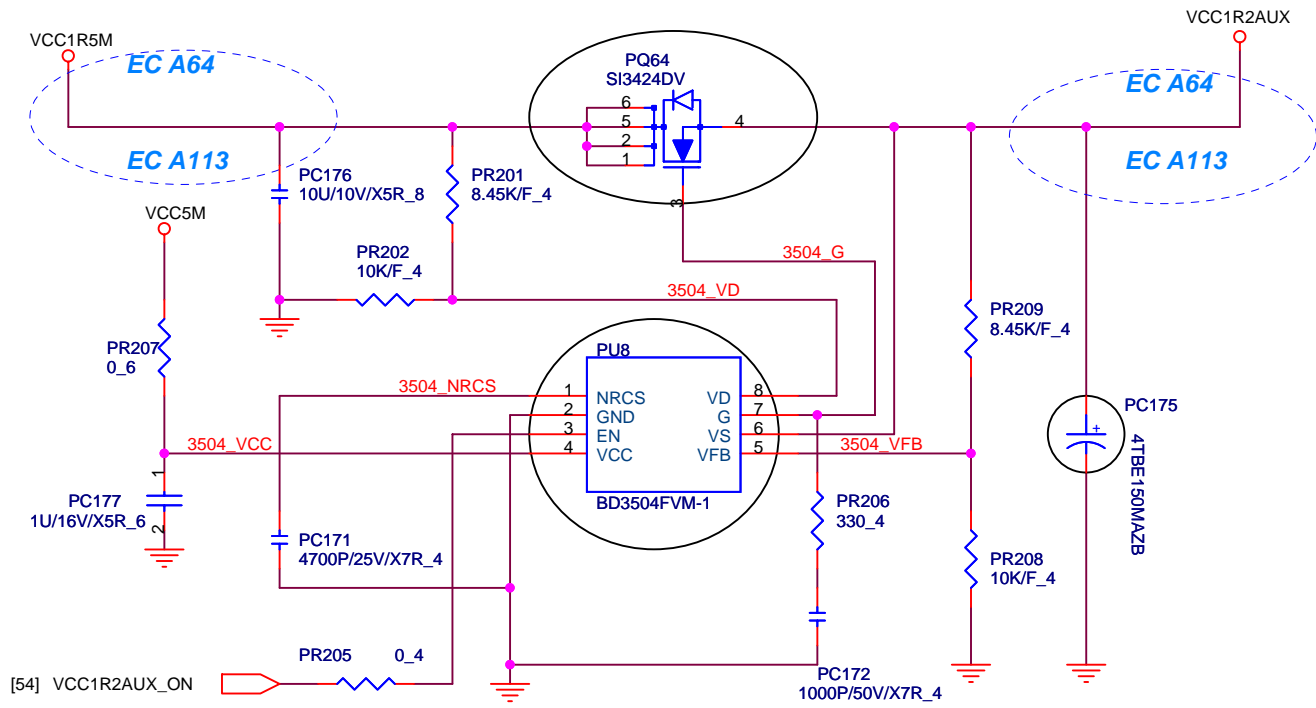

**PROJECT : BV1**  
**Quanta Computer Inc.**

Size A4	Document Number <b>LOAD SW_VIDEO</b>	Rev <b>3A</b>
Date: <b>Monday, May 09, 2005</b>	Sheet <b>63</b> of <b>72</b>	





		<b>PROJECT : BV1</b> <b>Quanta Computer Inc.</b>	
		Size A4 Document Number <b>LOAD SW_AUX</b>	Rev <b>3A</b>
Date: Monday, May 09, 2005		Sheet	64 of 72

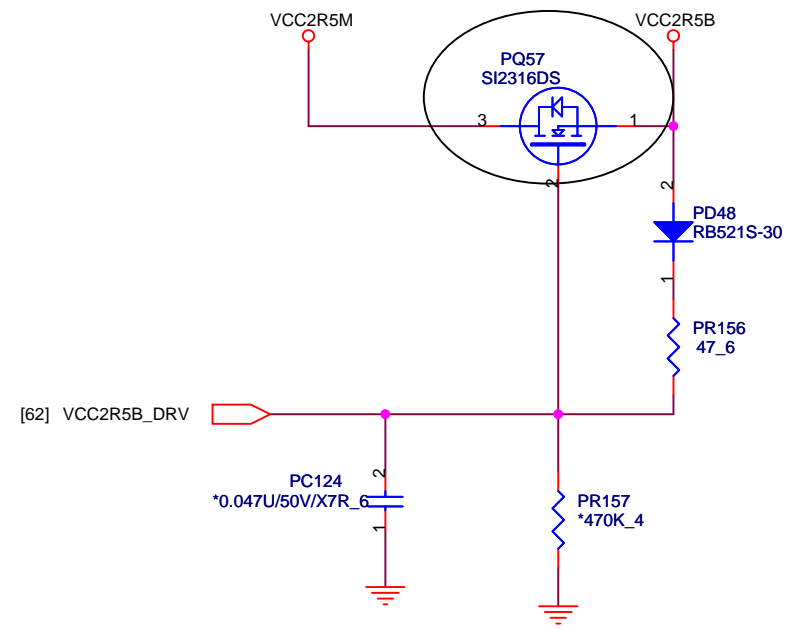
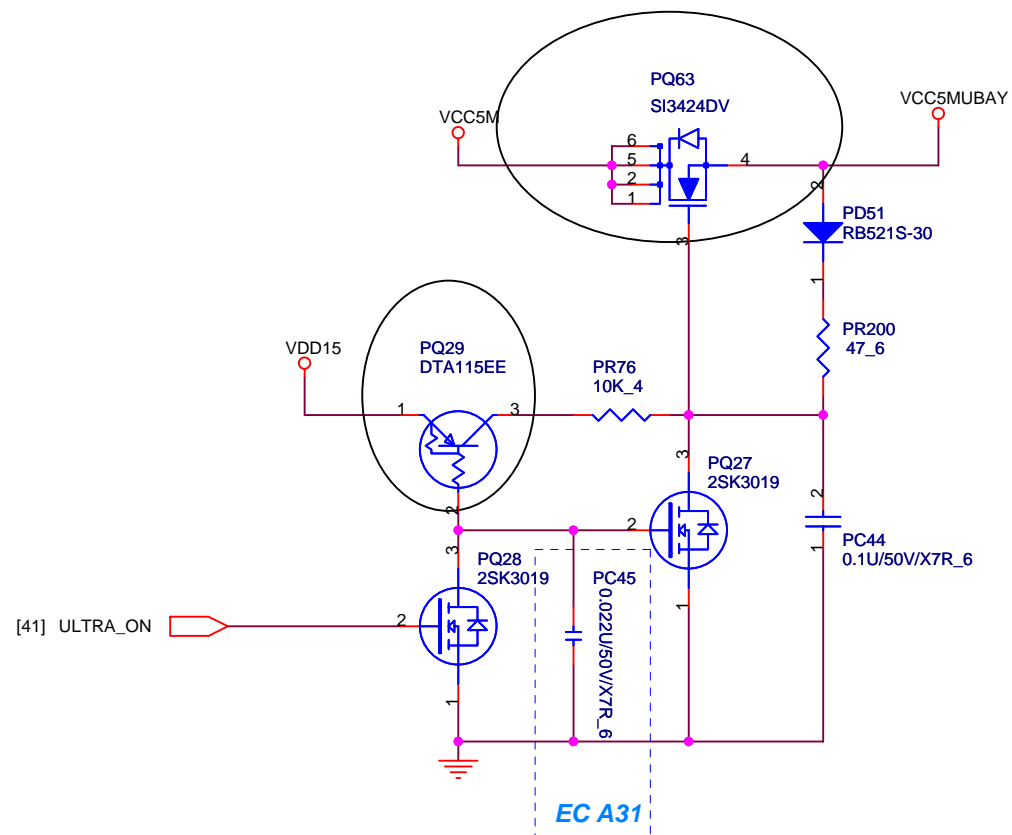

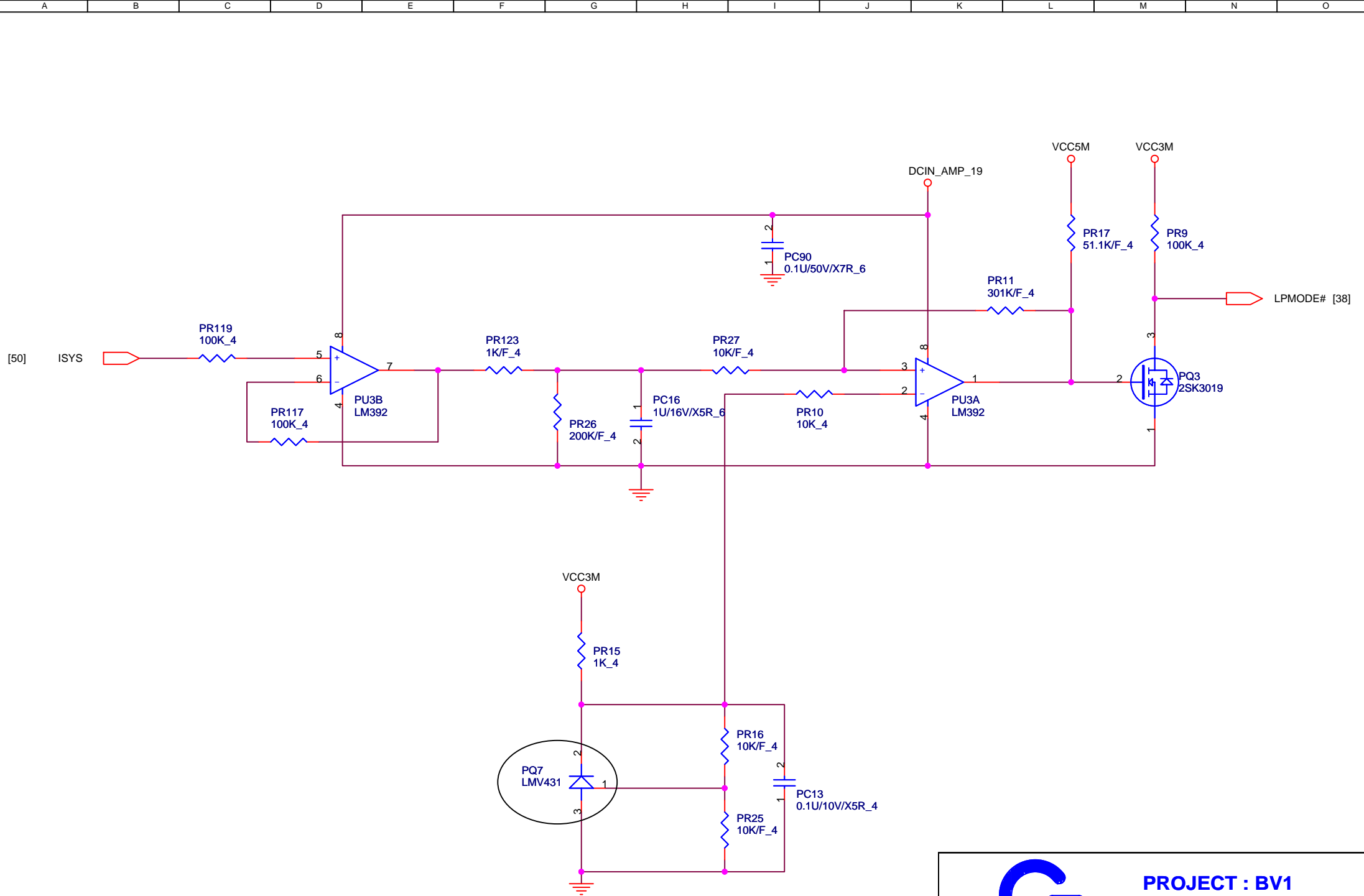

		<b>PROJECT : BV1</b> <b>Quanta Computer Inc.</b>	
		Document Number <b>LOAD SW_B_UBAY</b>	Rev <b>3A</b>
Date: Monday, May 09, 2005		Sheet 65 of 72	



		<b>PROJECT : BV1</b> <b>Quanta Computer Inc.</b>	
		Size A4 Document Number <b>MAX POWER CTRL</b>	Rev <b>3A</b>
Date: Monday, May 09, 2005		Sheet 66 of 72	

# SCREW HOLE

## MDC SCREW HOLE

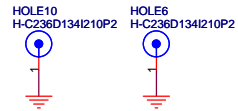

## LCD SCREW HOLE

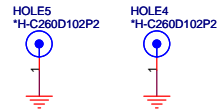

## CPU SCREW HOLE

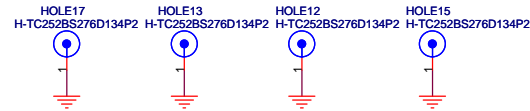

## PCMCIA SCREW HOLE

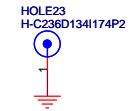

## M/B SCREW HOLE

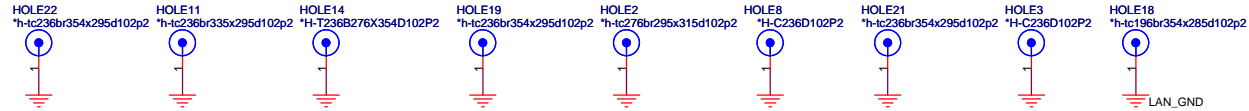

## MINI PCI-E LATCH SCREW HOLE

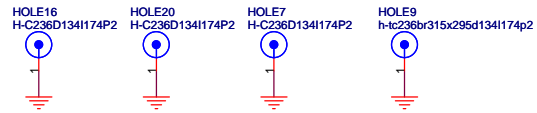

## EMI SPRINGS

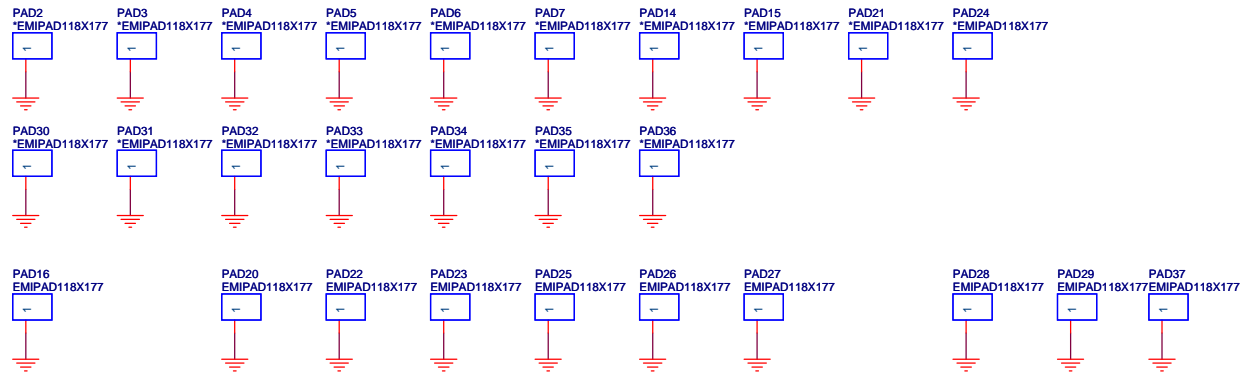

PROJECT : BV1  
Quanta Computer Inc.

## Revision History

Revision	Date	Phase	Change List	Release Schematic Date	Release Gerber File Date
1A	12/28 2004	DV	Initial release	12/28 2004	12/28 2004
2A	02/28 2005	SIV	See page 69 Record A-1 ( EC A01 - EC A52 ) See page 70 Record A-2 ( EC A53 - EC A106 ) See page 71 Record A-3 ( EC A107 - EC A130 )	03/07 2005	03/07 2005
3A	04/19 2005	SIT	See page 72 Record B-1 ( EC B01 - EC B?? )	05/09 2005	

## Schematic Value Explanation Description :

### RESISTOR

Value	F	4	6	8	12	1210	*	Description
*1K/F_4	1%	0402 (1005 )					NOASM	1K ohm 1% SMD 0402 package and NOASM
1K_6	5%		0603 (1608 )				ASM	1K ohm 5% SMD 0603 package and ASM
1K_8	5%			0805 (2125 )			ASM	1K ohm 5% SMD 0805 package and ASM
1K_12	5%				1206 (3216 )		ASM	1K ohm 5% SMD 1206 package and ASM
1K_1210	5%					1210 (3225 )	ASM	1K ohm 5% SMD 1210 package and ASM

### CAPACITOR

Value	Voltage	Material	6				*	Description
*0.1U/10V/X5R_4	10V	X5R	0402 (1005 )				NOASM	0.1UF 10V X5R SMD 0402 package NOASM
1U/25V/X7R_6	25V	X7R	0603 (1608 )				ASM	0.1UF 25V X7R SMD 0603 package ASM



PROJECT : BV1  
Quanta Computer Inc.

**BV1 / M-Note Schematic EC Tracking Record A ( for DV --> SIT ) Dec. 28, 2004**

**EC #/Page/Description/Part Affected/CMVC #**

- EC A01/04/ Change R268,R267 from NO ASM to ASM 40.2 ohm 1% because the SMVREF[1:0] voltage will droop below specification 200uA ( Intel plan fix in C1 stepping).
- EC A02/11/ Add RP11 33ohm 4P2R resistor to ASM , the reason is for MINI-PCIE clock use.
- EC A03/16/ Change Y6 32.768Khz crystal pin definition because it's different with layout footprint.
- EC A04/19/ Change R21 from 180k to 20k ohm and C45 from 0.1uF to 1uF. This recommendation change is being made in order to reduce the likelihood of glitching on RTCRST#.
- EC A05/28/ Change SD connector type to 2WX11101-1X-7F.
- EC A06/29/ Change R404,R406 from ASM to NO ASM. Because pull high resistor was double used on Page 29 and Page 62,41.
- EC A07/32/ Change Y5 25Mhz crystal pin definition because it's different with layout footprint.
- EC A08/38/ Change R84,R95,R94,R454,R85 to NO ASM. Because these resistors was double side pull high.
- EC A09/46/ Change U16 MAX1989 thermal sensor pin5,6 from capacitor to 0 ohm resistor between the two pins. Because if DXP,DXN not use must short of them.
- EC A10/46/ Change Q23,Q24 transistor pin definition because it's different with layout footprint.
- EC A11/48/ Add a 10k ohm pull high resistor to VCC3B for Q21 base driver and ASM.
- EC A12/50/ Change PC77 from 0.1uF/50V/X7R to 0.01uF/50V/X7R.
- EC A13/50/ Make "8724\_LDO\_3D3V" by using pin\_LDO and change PU5 pin12 REFIN power plane from VCC3M to 8724\_LDO\_3D3V.
- EC A14/50/ Change PC15 from NO ASM to ASM 1000P/50V/X7R.
- EC A15/50/ Change PU5 pin17 CELLS pull high power plane from VCC3M to 8724\_LDO\_3D3V. ( SIV-IBM-48 )
- EC A16/50/ Change PQ2 MOSFET from SI4804BDY to SI4978BDY.
- EC A17/50/ Add a 0 ohm resistor between the 8724\_AGND and digital GND. Because PU5 MAX8724ETI ground was floating.
- EC A18/52/ Change PC3,PC4,PC108,PC114 from ASM to NO ASM. The reason is battery smbus signal rising time is out of spec. Because the smbus clock frequency is reduced to 1/2 so the total communication time is twice. Also, Sanyo battery has a PEC error problem. CMVC# 65982 ( SIV-IBM-12 )
- EC A19/54/ Change PR85,PD32 from NO ASM to ASM.
- EC A20/55/ Change PL10 pin definition because it's different with layout footprint.
- EC A21/56/ Change PR70 from 324 ohm 1% to 383 ohm 1%.
- EC A22/56/ Change PR169 from 324 ohm 1% to 383 ohm 1%.
- EC A23/56/ Change PC146 from 330pF/50V/X7R to 680pF/50V/X7R.
- EC A24/58/ Add a 0.22uF/10V/X7R.
- EC A25/59/ Add a 0.22uF/10V/X7R.
- EC A26/59/ Add a 0.22uF/10V/X7R.
- EC A27/62/ Change PC47 derating from 0.047uF/16V/X7R to 0.047uF/50V/X7R.
- EC A28/62/ Change PC42 from 0.047uF/16V/X7R to 0.1uF/50V/X7R. Because VCC3B sequence must be early than VCC2R5B 0.7V DC level.
- EC A29/62/ Change PQ65,PQ61 MOSFET from SI4890DY to TPC 8016-H MOSFET.
- EC A30/64/ Change PC169 derating from 0.047uF/16V/X7R to 0.047uF/50V/X7R.
- EC A31/65/ Change PC45 derating from 0.022uF/16V/X7R to 0.022uF/25V/X7R.
- EC A32/37/ Add ACDC\_ID signal from docking. CMVC# 65894 ( SIV-IBM-01 )
- EC A33/38/ Change USB\_ON and DOCK\_USB\_ON signal from pull high to pull down. ( SIV-IBM-02 )
- EC A34/37/ Change pull high signal for DOCK\_ATTACHED# from VCC3B to VCC5B. ( SIV-IBM-05 )
- EC A35/31,37/ Change signal name to clarify from LAN\_DOCK\_ATTACHED# to LAN\_DOCK\_ATTACHED\_AUX#. ( SIV-IBM-06 )
- EC A36/15,37/ Change signal name to clarify from DOCK\_ATTACHED# to DOCK\_ATTACHED\_5B#. ( SIV-IBM-06 )
- EC A37/15/ Change VCCCRT power source. ( SIV-IBM-07 )
- EC A38/37/ Add docking attach signal with pull-up to VCC3M to H8. ( SIV-IBM-08 )
- EC A39/37/ Add 2 caps 0.1U and 4.7U at LAN\_MAG\_CTAP near docking connector. ( SIV-IBM-09 )
- EC A40/17/ Change PlanarID [3..0] from 0000 to 0001. ( SIV-IBM-11 )
- EC A41/55,58,59,61,64/ Delete solder jumpers of power pads. ( SIV-IBM-13 )
- EC A42/38/ Delete dock\_attach# pull high resistor 100K R96 and charge\_current0 pull high R454.
- EC A43/38/ Change signal name from "DOCK\_ATTACH#" to "DOCK\_ATTACHED\_3M#".
- EC A44/52/ Change main & second battery connector from 5pin to 7pin. ( SIV-IBM-15 )
- EC A45/47/ Change SES AT8356908 SMBUS switch path for SW request.
- EC A46/35/ Change C360,C346,C133,C134 the signal filter of modem from 470pf to 1000pf for EMI request.
- EC A47/35/ Add bypass cap on RJ45\_ACTIVITY\_SYS# and RJ45\_LINKUP\_SYS# signal ,the value is 1000pf for EMI request.
- EC A48/35/ Add two resistor (0 ohm)to connect the Digital ground and LAN\_GND for EMI request.
- EC A49/34/ Change the power filter of LAN from 0 ohm to BLM18AG601SN1D for EMI request.
- EC A50/55/ Change PL9 to GANSHIN(CDRH104RNP-5R2NC-EP)
- EC A51/59/ Change PL6 to CDRH104R\_1R5UH\_10A.
- EC A52/19/ Delete EEPROM PLCC32 socket package. ( SIV-IBM-18 )

		<b>PROJECT : BV1</b>	
		<b>Quanta Computer Inc.</b>	
Size	Document Number	Rev	
Custom	EC Record	3A	
Date:	Monday, May 09, 2005	Sheet	69 of 72

**BV1 / M-Note Schematic EC Tracking Record A ( for DV --> SIT ) Dec. 28, 2004**

**EC #/Page/Description/Part Affected/CMVC #**

- EC A53/04/ Change L35 filter bead from BLM18PG181SN1 to inductor 1uH.
- EC A54/04/ Change L34 filter bead from BLM18PG181SN1 to inductor 91nH.
- EC A55/04/ Change L19 inductor from 10uH to 1uH.
- EC A56/37/ Change R32 from 1002 to 1608 size on LAN\_MAG\_TAP power trace. ( SIV-IBM-19 )
- EC A57/05/ Change termination resister for Alviso composite TVout from 150ohm to 75ohm. ( SIV-IBM-20 )
- EC A58/37/41/ Delete a gate logic from docking PCIE\_WAKE# signal. ( SIV-IBM-21 )
- EC A59/23/ Change R124 value from 33 ohm to 39 ohm. ( SIV-IBM-22 )
- EC A60/23/ Add a cap 47P/50V/NPO for AC\_BITCLK signal and NO ASM. ( SIV-IBM-22 )
- EC A61/16/23/27/ Change signal name on Azalia interface. ( SIV-IBM-22 )
- EC A62/27/ Change R154 from 33 ohm to 0 ohm.
- EC A63/25/ Add internal MIC Bias logic circuit. CMVC# 66010/66014 ( SIV-IBM-23 )
- EC A64/64/ Add filter HI0805R800R-10(5A) between VCC1R5M and VCC1R2AUX for EMI request.
- EC A65/47/ Change R167,D17 to NO ASM and add series resistor between U27 pin31 and PCIRST# for ATMEL FAE recommend.
- EC A66/32/ Change value of R247,R50,C299,C302 for IEEE lan measurement.
- EC A67/08/ Add decouping capacitor of alviso power pin.
- EC A68/25/ Change headphone selection circuit. ( SIV-IBM-29 )
- EC A69/24/ Delete R555 pad. ( SIV-IBM-23 )
- EC A70/24/ Change R525 to NO ASM. ( SIV-IBM-23 )
- EC A71/24/ Change micphone selection circuit. ( SIV-IBM-23 )
- EC A72/37/ Change net name from DOCK\_MICIN\_DTCT to DOCK\_MICIN\_DTCT# , DOCK\_HPOUT\_DTCT to DOCK\_HPOUT\_DTCT#. ( SIV-IBM-29 )
- EC A73/23/ Change +EQ\_BYPASS circuit. ( SIV-IBM-23 )
- EC A74/23/ Add stereo external micophone circuit. ( SIV-IBM-23 )
- EC A75/31/ Delete ESD lan switch diode.
- EC A76/23/ Delete R130 pad.
- EC A77/20/ Alignment guide pin of SATA HDD connector should be soldered to GND pad ( SIV-IBM-30 )
- EC A78/35/ Add ESD TVD diode (SRV05-4) NO ASM near RJ45 connector side. ( SIV-IBM-28 )
- EC A79/38/ Change H8 charge circuit. ( SIV-IBM-31 )
- EC A80/38/ Keep CHARGE\_CELL0 , CHARGE\_CELL1 pull high resistor.
- EC A81/31/ Add capacitors on lan switch power line. ( SIV-IBM-32 )
- EC A82/43,44/ Add capacitors on MINI PCI-E power line. ( SIV-IBM-32 )
- EC A83/15/ Change bead/capacitors value for CRT waveform measurement. ( SIV-IBM-34 )
- EC A84/23/ Add a series resistor 33 ohm on SPDIF\_OUT signal. ( SIV-IBM-35 )
- EC A85/11/ Change R366,R378 from 100k to 10k ohm. ( SIV-IBM-36 )
- EC A86/22/ Delete Clamp Diode and Add TVS diode (SEMTECH SRV05-4) on USB port 1,2. ( SIV-IBM-38 )
- EC A87/22/ Change USB conn for SIV.
- EC A88/58/ Change PR214,PR217 to from 1.5k to 732 ohm 1%.
- EC A89/58/ Change PR250 from 49.9k 1% to 69.8k 1% ohm.
- EC A90/59/ Change PR168,PR181 from 1.5k 1% to 732 1% ohm.
- EC A91/59/ Change PR182,PR183 from 1.5k to 576 ohm 1%.
- EC A92/59/ Change PR174 from 49.9K 1% to 48.7K 1% , PR188 from 49.9K 1% to 69.8K 1%.
- EC A93/50/ Change PC11,PC10,PC7,PC79,PC8,PC58,PC63,PC65,PC66 from TMK325BJ475KN-T to TMK325BJ475KN-H.
- EC A94/55/ Add a POSCAP capacitor "6TPE220MI (220uF/6.3V/ESR=18mohm, 7343size, H=2.0mm\_max) on VCC3M power line and NOASM
- EC A95/50/ For the accuracy of Charge Voltage (Cell voltage), pin\_REFIN and "CHARGE\_VOLT" signal should use same Power Net, and it was VCC3M.
- EC A96/50/ Modify pin\_ICTL circuit.Pin\_ICTL should also use 8724\_LDO\_3D3V.
- EC A97/50/ Modify pin\_CSSN to support Docking System.
- EC A98/11/ Modify clock gen driven buffer.
- EC A99/28/ Change PCMCIA connector vendor.
- EC A100/38/ Delete R84 resistor pad,it's un-necessary pull-up.
- EC A101/40,47/ Connect TATER signals from ATMEL to TouchPad connector. ( SIV-IBM-40 )
- EC A102/23/ Add 0ohm pad (NOASM) on SPDIF\_RTN signal. ( SIV-IBM-41 )
- EC A103/49/ Prepare to support new STMicro G-sensor. ( SIV-IBM-43 )
- EC A104/14/ Add bypass cap and delete some caps on LCD signal for EMI request.
- EC A105/39/ Add bypass cap on KB signal for EMI request.
- EC A106/37/ Add bypass cap on docking signal for EMI request.

		<b>PROJECT : BV1</b>	
		<b>Quanta Computer Inc.</b>	
Size	Document Number	Rev	
Custom	EC Record	3A	
Date:	Monday, May 09, 2005	Sheet	70 of 72

- EC A107/50/ Change PR152 from 12.7k 1% 11.3k 1% ohm. ( SIV-IBM-44 )
- EC A108/50/ Change PR130 from 18.2k 1% 19.1k 1% ohm. ( SIV-IBM-44 )
- EC A109/50/ Change PR29 from 100k 1% 100k 0.5% ohm ; PR135 from 13k 1% 12.7k 0.5% ohm. ( SIV-IBM-44 )
- EC A110/50/ Change PC112 from 0.01U/25V/X7R to 1000p/50V/X7R.
- EC A111/51/ Change PQ49,PQ12 from SI2301BDS to SI2303BDS.
- EC A112/53/ Update footprint and change PD26,PD27 footprint to DSM.
- EC A113/64/ Delete PL22,PL23 for IBM power request.
- EC A114/41/ Change R400 from 6.8k to 100k ohm.
- EC A115/50/ Change PR260 from 10K 1% to 10 ohm 1%. ( SIV-IBM-48 )
- EC A116/50/ Delete PR120,PR121 pad.
- EC A117/50/ Change PC94 from 0.1U/16V/X7R to 0.01U/25V/X7R.
- EC A118/59/ Improve power function for QCI power team request.
- EC A119/58/ Improve power function for QCI power team request.
- EC A120/35/ Change RJ11+RJ45 connector vendor and footprint.
- EC A121/02/ Add a 100pF cap between cpu THERMDA , THERMDC signal and NOASM.
- EC A122/22/ Change SRV05-4 pin5 to VCC5M. ( SIV-IBM-49 )
- EC A123/50/ Change charge description.
- EC A124/24,25/ Change R554,R573 to NOASM and R572 to ASM.
- EC A125/40,47/ Change signal name SES\_EN# to SES\_EN.
- EC A126/51/ Change PR107 from 470K to 75K ohm.
- EC A127/14/ Change C212 from 0.047U/50V/X7R\_6 to 0.1U/50V/X7R\_6.
- EC A128/61/ Change PU6 value from "MAX1589ETA-T to MAX1589ETT250+TW".
- EC A129/55,56/ Change PC135,PC139,PC137,PC138,PC24,PC136,PC133,PC132,PC134,PC131,PC23,PC130,PC56 value from "ECPU1E105JBM" to "GRM31MR71E225KA93L".
- EC A130/62/ Change PC115 to NOASM.
- EC A131/37/ Change F3 to NANOSMDC050F.
- EC A132/28/ Change R443 to 10 ohm.
- EC A133/11/ Change R358, R84, R131, R132, R581 to 12.1 ohm 1%.
- EC A134/35/ Change C666,C667 to NOASM for homologation.
- EC A135/37/ Change R130 from NOASM to ASM.

- EC B01/61/ Change PU6 from"MAX1589ETT250+TW" to "MAX1589A". ( SIT-IBM-01 )
- EC B02/38/ Change Wireless Disable switch circuit. ( SIT-IBM-03 )
- EC B03/47/ Change reset signal change for TPM/TATER chip. ( SIT-IBM-04 )
- EC B04/17/22/ Change divide USB OC# signal. ( SIT-IBM-05 )
- EC B05/43/44/ Remove MINI PCI-E latch pad. ( SIT-IBM-09 )
- EC B06/17/ Planar ID change to SIT "3". ( SIT-IBM-10 )
- EC B07/47/ 0.01uF capacitor add on VCC3M at U27(Atmel 8356908). ( SIT-IBM-12 )
- EC B08/39/ Change R275 to NO ASM. ( SIT-IBM-13 )
- EC B09/51/ Add pull down resistor for charger inrush. ( SIT-IBM-14 )
- EC B10/38/ Change R104 to NO ASM. ( SIT-IBM-15 )
- EC B11/29/ Change PCMACT pull high from VCC3M to VCC3B. ( SIT-IBM-16 )
- EC B12/38/ Change R99 to NO ASM. ( SIT-IBM-17 )
- EC B13/30/ Change IEEE1394 common choke from DLW21SN261SQ2L (260ohm@100Mhz) to DLW21SN121SQ2L (120ohm@100Mhz). ( SIT-IBM-18 )
- EC B14/50/ Change MAX8724 pin\_SHDN# circuit . ( SIT-IBM-20 )
- EC B15/50/ Change MAX8724 pin\_IINP# circuit . ( SIT-IBM-21 )
- EC B16/14/ Change Q16 FET from SI3424DV to SI4890DY. ( SIT-IBM-22 )
- EC B17/50/ Change for AC Adapter polarity Test Fail. ( SIT-IBM-26 )
- EC B18/38/ Change GPIO\_BT Pull up to Pull down. ( SIT-IBM-27 )
- EC B19/50/ Change PQ46 from SI4890DY to SI4840DY. ( SIT-IBM-26 )
- EC B20/35/ Change CN7 connector of pin3,4 to non ground pin for safety Hi-port test.
- EC B21/35/ Remove C666,C667 pad.
- EC B22/48/ Add 10uF/10V capacitor for VCC5B voltage drop while FAN turn on.
- EC B23/19/ Reserve R,C for EMI request.
- EC B24/14/ Change F4 to 1206 footprint.
- EC B26/56/ Add NO ASM capacitors " GRM21BR71E155K" in VINT19 power rail to prevent any issue may happen like Voltage Dip on VINT19 or LCD Flicker or Acoustic Noise etc... ( SIT-IBM-32 )
- EC B27/50/38/62/52/ Support 65W AC adapter. ( SIT-IBM-33 )
- EC B28/53/ Chagne PR220,PR215 from 5.62K/F to 6.04K/F. ( SIT-IBM-34 )
- EC B29/50/ Chagne PR96 from 470K 5% to 220K 5%. ( SIT-IBM-35 )
- EC B30/24/ Chagne R526 from 10K 5% to 36K 5% ; R485 from 8.2K 5% to 16K 5%. ( SIT-IBM-36 )
- EC B31/20/ Add 10 10V X5R capacitors near SATA connector. ( SIT-IBM-37 )
- EC B32/55/ Add 100k 5% resistor between MAX1901 pin VL and pin SKIP#. ( SIT-IBM-39 )
- EC B33/42/ Add 0 ohm resistor between DOCKING and SIO. ( SIT-IBM-40 )
- EC B34/47/ 0.01uF capacitor add on RTCVCC at U27(Atmel 8356908). ( SIT-IBM-41 )
- EC B35/07/ Add 10uF/10V/X5R capacitor for TVDAC power noise.
- EC B36/51/ Remove PD42,PD43,PD12,PD14.
- EC B37/35/ Change C133,C134 from 470pF to 1000pF and C607,C608 to ASM for EMI request.
- EC B38/11/ Change R352 from 33 ohm to 75 ohm for 48 Mhz slew rate fail issue.
- EC B39/11/ Change PCICLK 33MHz circuit for signal quality.
- EC B40/19/ Remove G2 short pad for IBM request.
- EC B41/49/ Correct G-sensor STMicro table as same as ADI.
- EC B42/56/ EMI request
- EC B43/50/56/ Change PC56, PC135, PC139, PC137, PC138, PC24, PC136, PC133, PC132, PC134, PC131, PC23, PC130 from GRM31MR71E225KA93L to GRF31CR72A105K
- EC B44/05/ Change R212 from 255/F to 249/F. ( SIT-IBM-44 )
- EC B45/47/ Change R293 to NOASM , D17 to ASM. (SIT-IBM-43)
- EC B46/48/ Change R563 to NOASM.