

# BERLIN 10G

## M96/M92/Madison/Park

# MP Build

2010.03.18

DATE	CHANGE NO.	REV

DRAWER	EE	DATE	POWER	DATE	<b>INVENTEC</b>			
DESIGN					TITLE <b>BL10G</b>			
CHECK								
RESPONSIBLE								
SIZE =	3			VER :	SIZE <b>A3</b>	CODE <b>CS</b>	DOC. NUMBER <i>Model No</i>	REV <b>X01</b>
FILE NAME :	XXXX-XXXXXX-XX				SHEET	1	OF	66
P/N	XXXXXXXXXXXX							

**TABLE OF CONTENTS**

<b>PAGE</b>	<b>PAGE</b>	<b>PAGE</b>
1. COVER PAGE	27.E-SATA	55. CARDREADER & USB BOARD
2. INDEX	28.USB CONN	56. EMI
3. BLOCK DIAGRAM	29.BLUETOOTH	57. GPU-1
4. POWER SEQUENCE BLOCK	30.WLAN/Debug Card	58. GPU-2
5. PCB SCREW	31.3G	59. GPU-3
6. SYSTEM POWER	32.Hall sensor	60. GPU-4
7. SYSTEM POWER	33.LED	61. GPU-5
8. SYSTEM POWER	34.CLOCK GENERATOR	62. GPU-6
9. SYSTEM POWER	35.DDR3 DIMM0	63. VRAM_DDR3
10.SYSTEM POWER	36.DDR3 DIMM1	64. VRAM_DDR3
11.SYSTEM POWER	37.CPU 1	65. VRAM_DDR3
12.VGA POWER	38. CPU 2	66. VRAM_DDR3
13.SYSTEM POWER	39. CPU 3	
14. EC	40. CPU 4	
15.K/B & TP/B CONN	41. CPU 5	
16.FAN & THERMAL	42. CPU 6	
17. LAN	43.PCH 1	
18.RJ45 & TRANSFORMER	44.PCH 2	
19. AUDIO CODEC	45.PCH 3	
20. AUDIO AMP	46. PCH 4	
21. MDC	47. PCH 5	
22. LCM CONN	48. PCH 6	
23.CRT CONN	49.PCH 7 POWER	
24.HDMI CONN	50.PCH 8 POWER	
25.USB CARDREADER	51.PCH 9	
26.SATA HDD/SSD & ODD	52.PICK BUTTON BOARD	
	53.TOUCH PAD SW BOARD	
	54. POWER BUTTON BOARD	

<b>INVENTEC</b>			
TITLE <i>BL10G</i>			
SIZE <b>A3</b>	CODE <b>CS</b>	DOC. NUMBER <i>Model No</i>	REV <b>X01</b>
CHANGE by <i>Drawer Name</i>		18-Oct-2009	
SHEET		2	OF 66

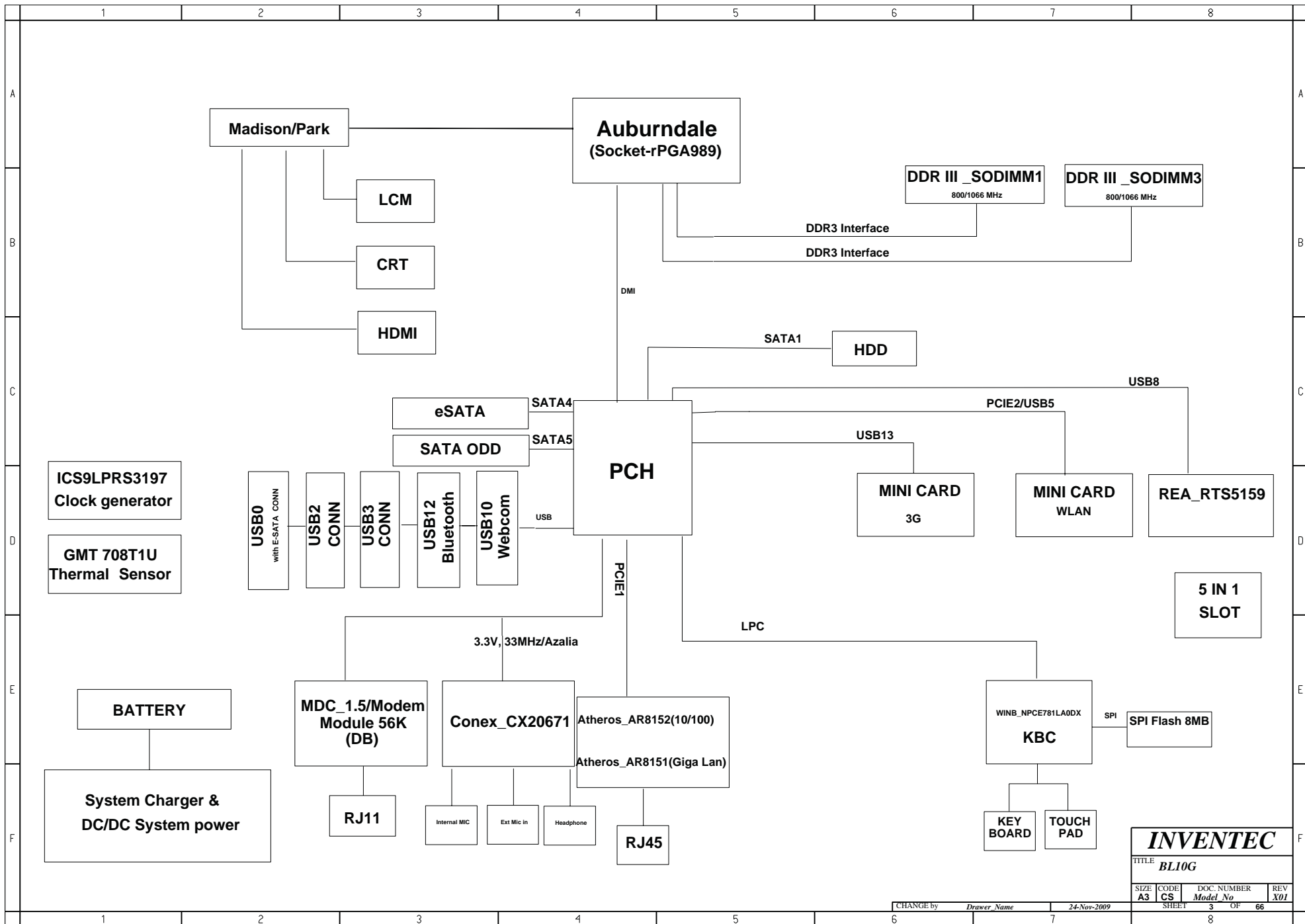

**INVENTEC**

TITLE  
BL10G

SIZE A3	CODE CS	DOC. NUMBER Model No	REV X01
------------	------------	-------------------------	------------

CHANGE by *Drawer Name* 24-Nov-2009

SHEET 3 OF 66

	1	2	3	4	5	6	7	8	
A	<p>Need to update power map.</p>								A
B									
C									
D									
E									
F									
	1	2	3	4	5	6	7	8	

<b>INVENTEC</b>			
TITLE <b>BL10G</b>			
SIZE <b>A3</b>	CODE <b>CS</b>	DOC. NUMBER <i>Model No</i>	REV <b>X01</b>
CHANGE by <i>Drawer Name</i>		23-Nov-2009	SHEET <b>4</b> OF <b>66</b>

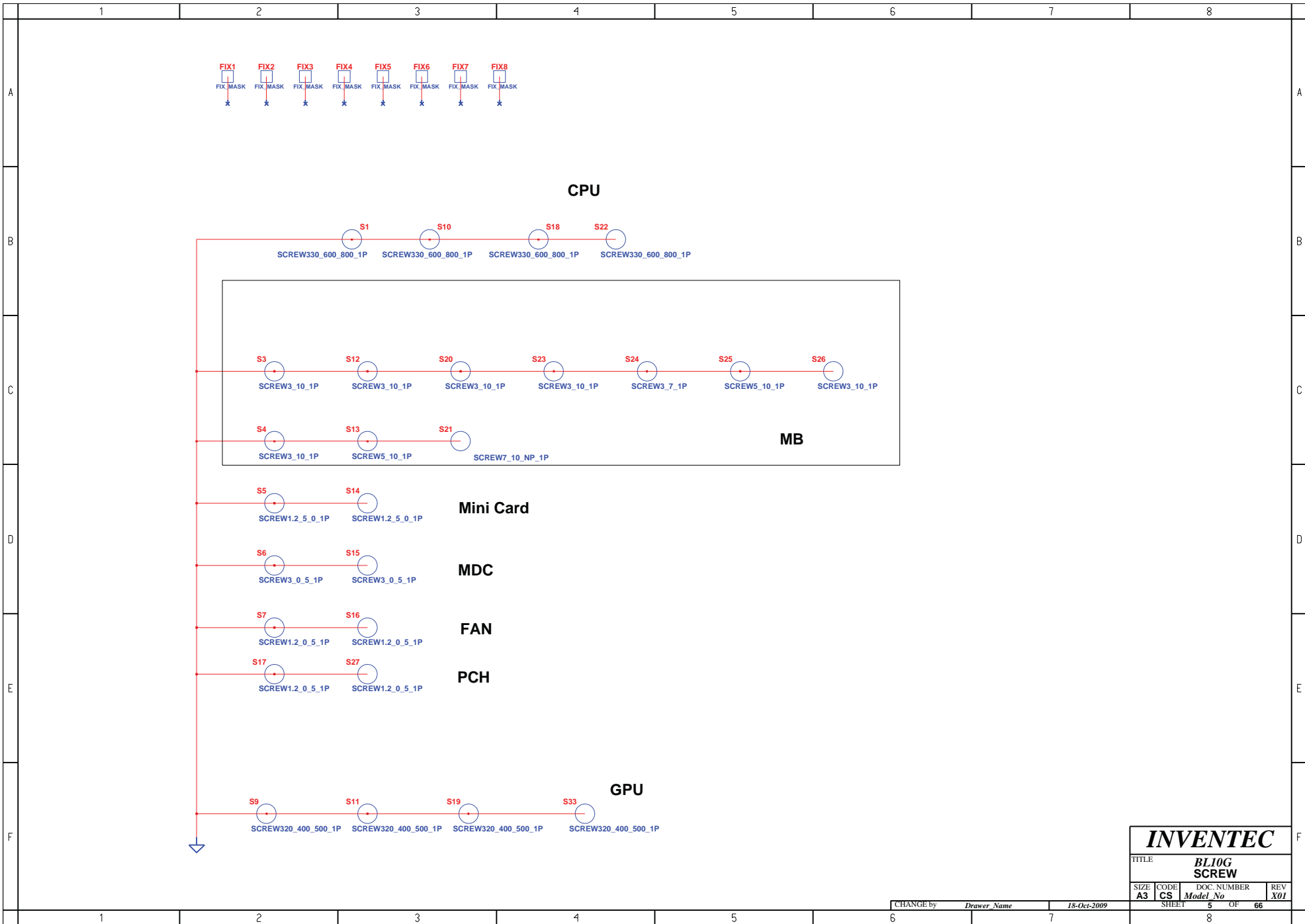

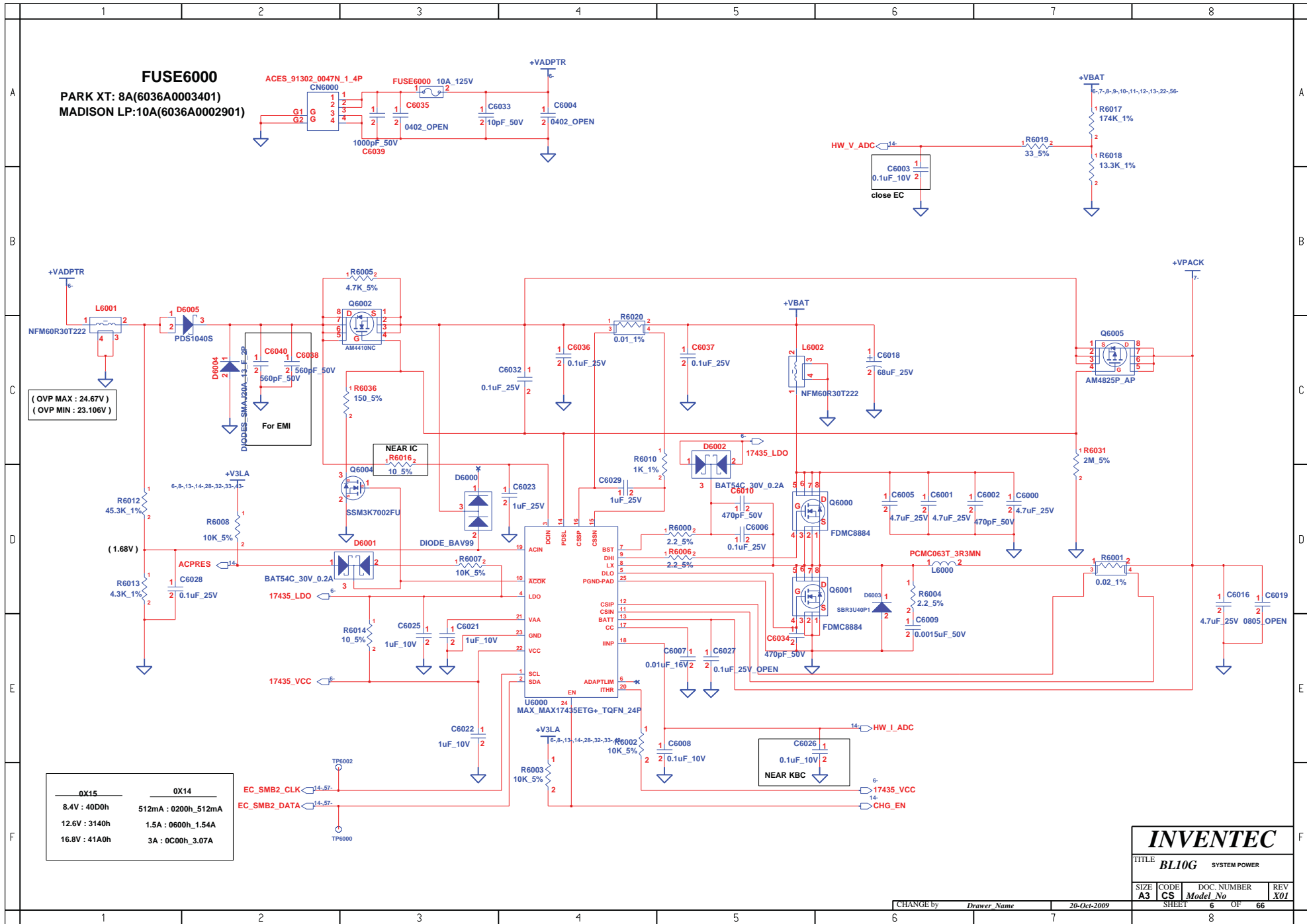

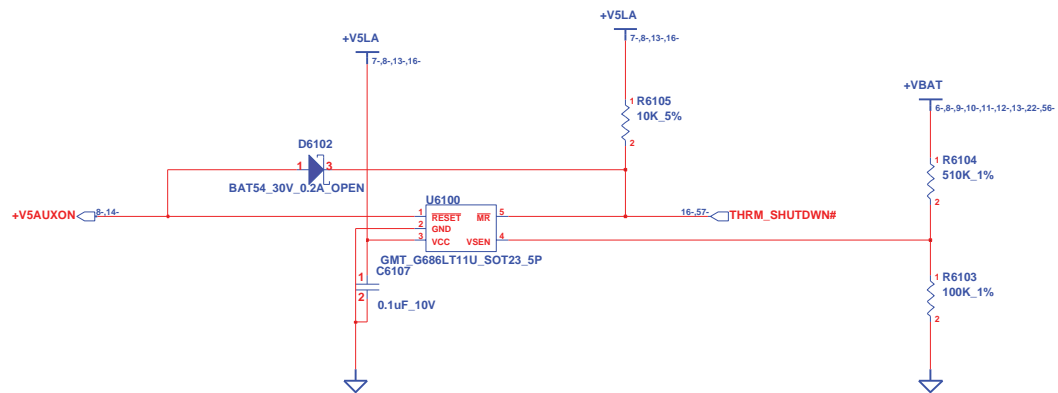
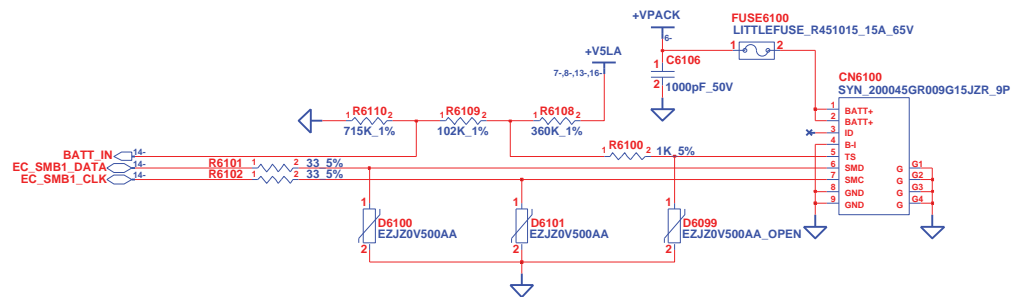

**INVENTEC**

TITLE  
**BL10G  
SELECT & BATTERY CONN**

SIZE <b>A3</b>	CODE <b>CS</b>	DOC. NUMBER <i>Model No</i>	REV <b>X01</b>
-------------------	-------------------	--------------------------------	-------------------

CHANGE by <i>Drawer Name</i>	18-Oct-2009	SHEET <b>7</b>	OF <b>66</b>
---------------------------------	-------------	-------------------	-----------------

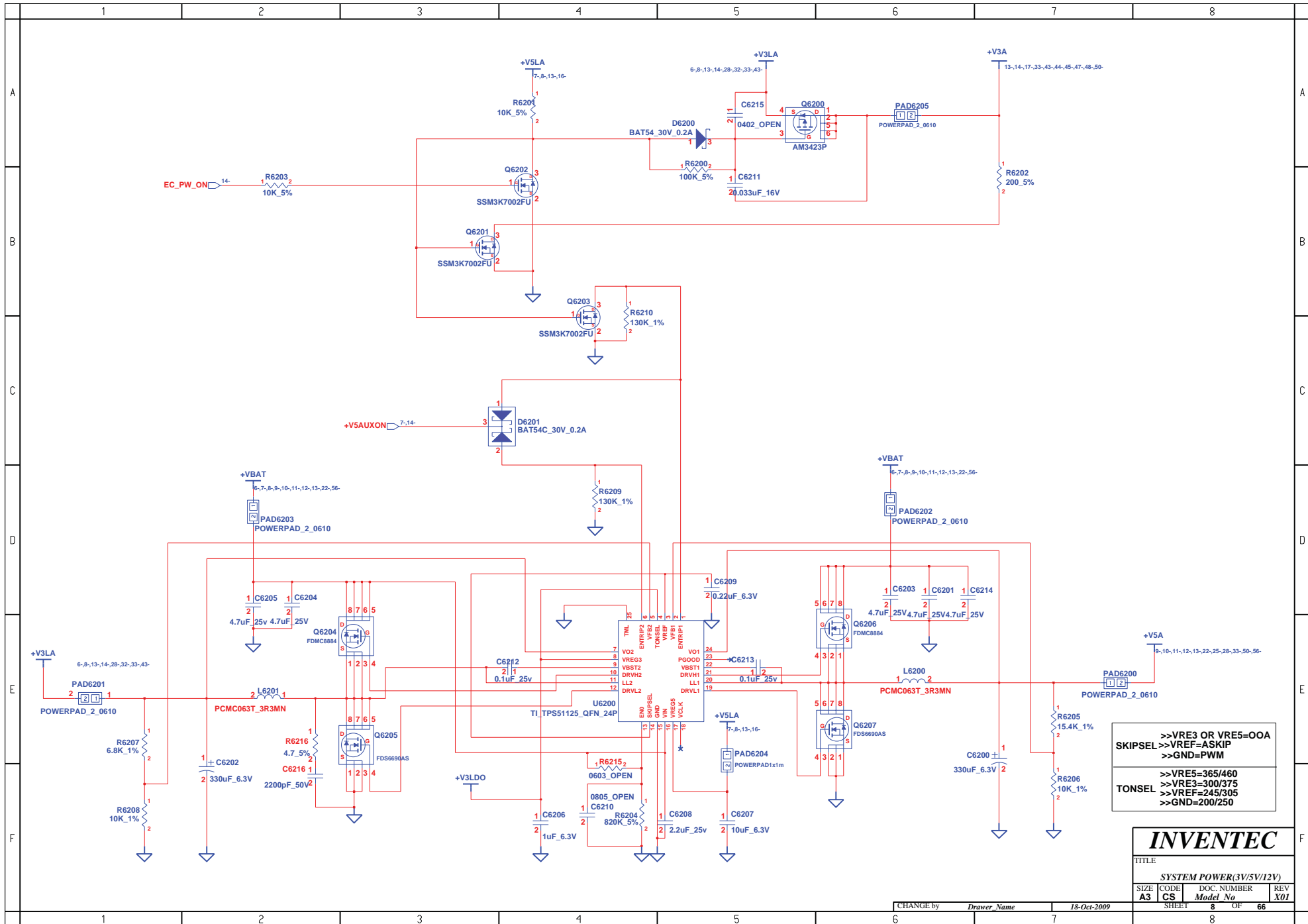



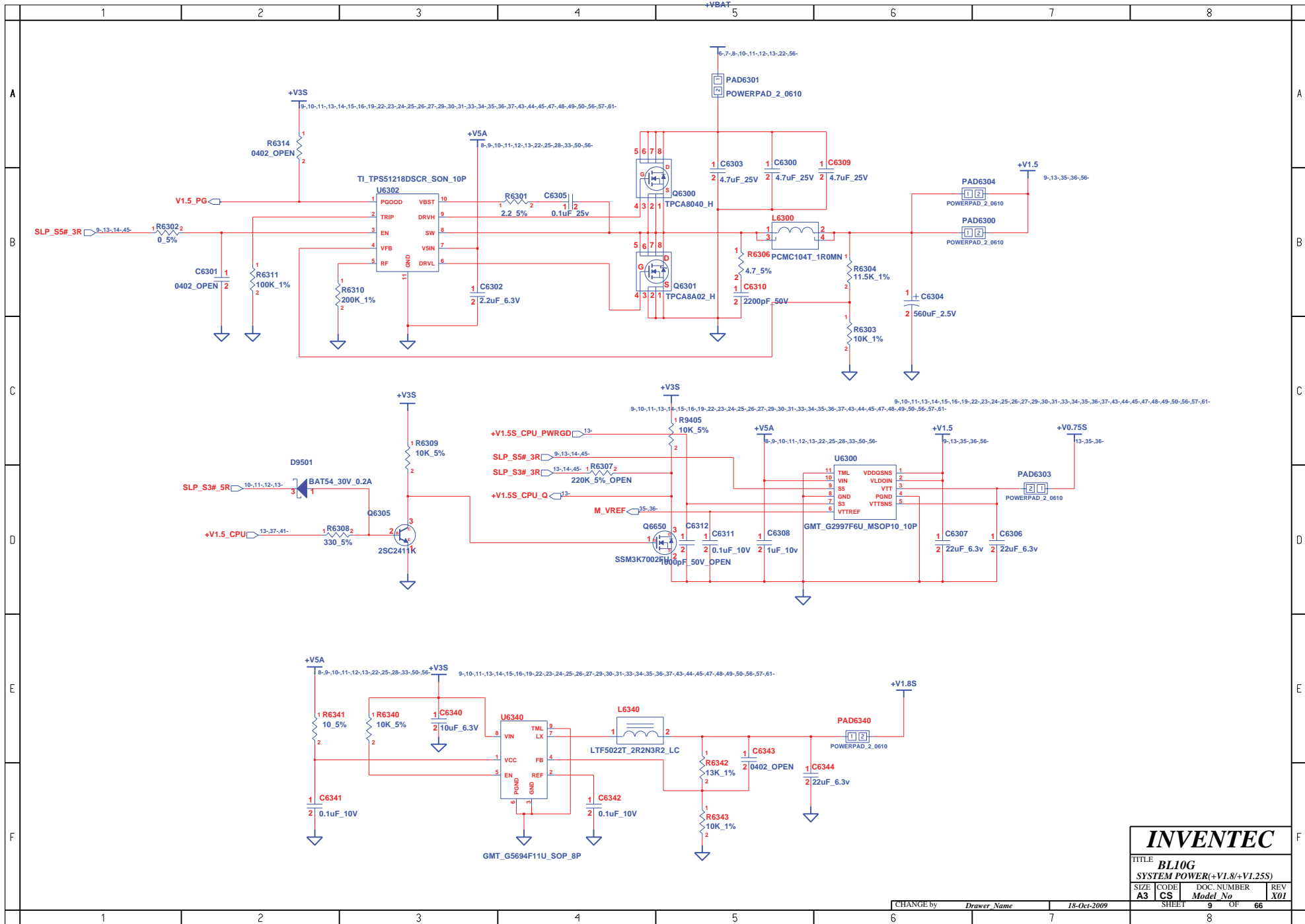

<b>INVENTEC</b>			
TITLE			
BL10G			
SYSTEM POWER(+V1.8/+V1.25S)			
SIZE	CODE	DOC. NUMBER	REV
A3	CS	Model No	X01
CHANGE by		Drawer Name	18-Oct-2009
SHEET		9	OF 66

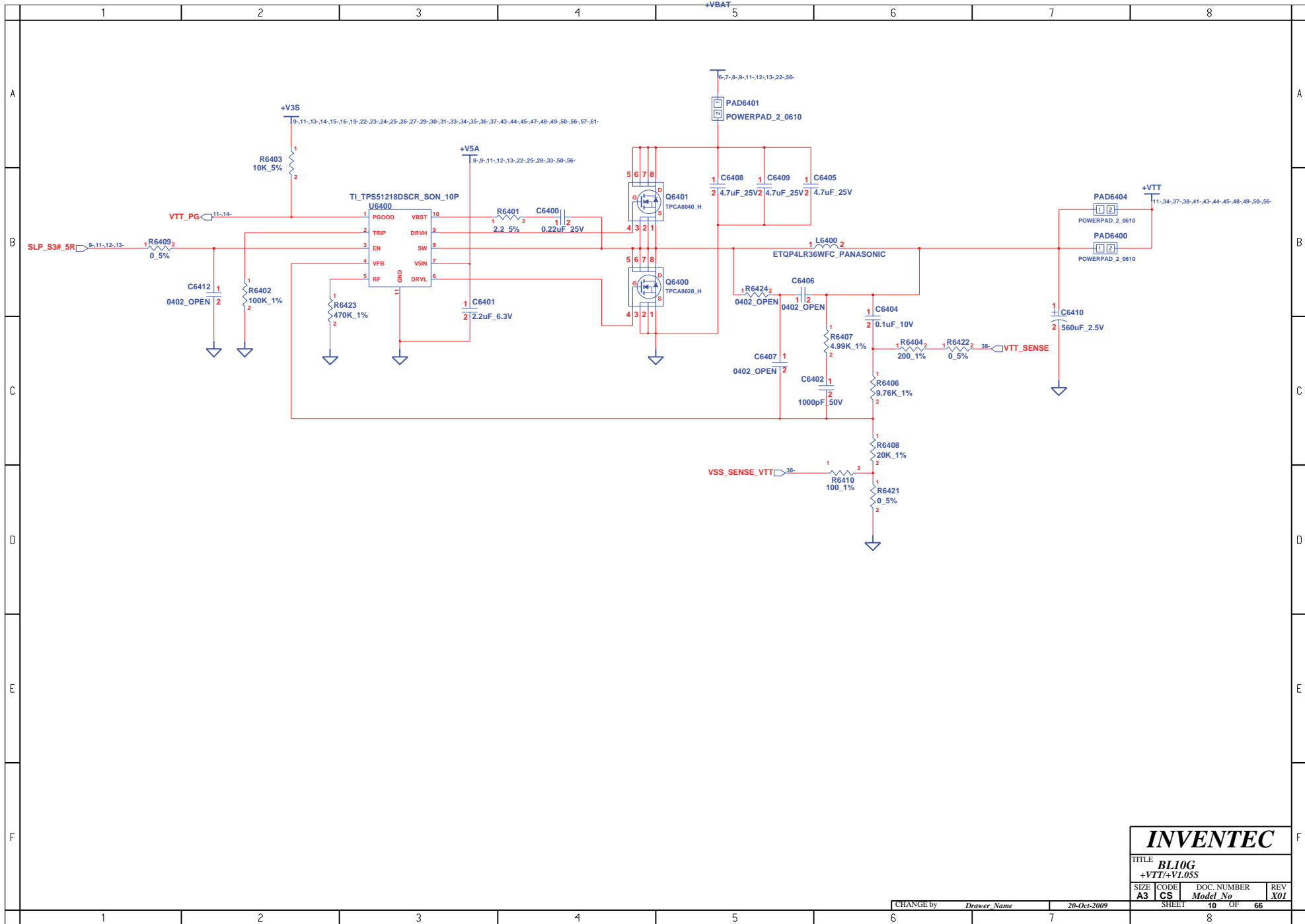

<b>INVENTEC</b>			
TITLE			
BLI0G			
+VTT/+V1.05S			
SIZE	CODE	DOC. NUMBER	REV
A3	CS	Model No	X01
CHANGE by <i>Drawer Name</i> 20-Oct-2009			SHEET 10 OF 66
			8

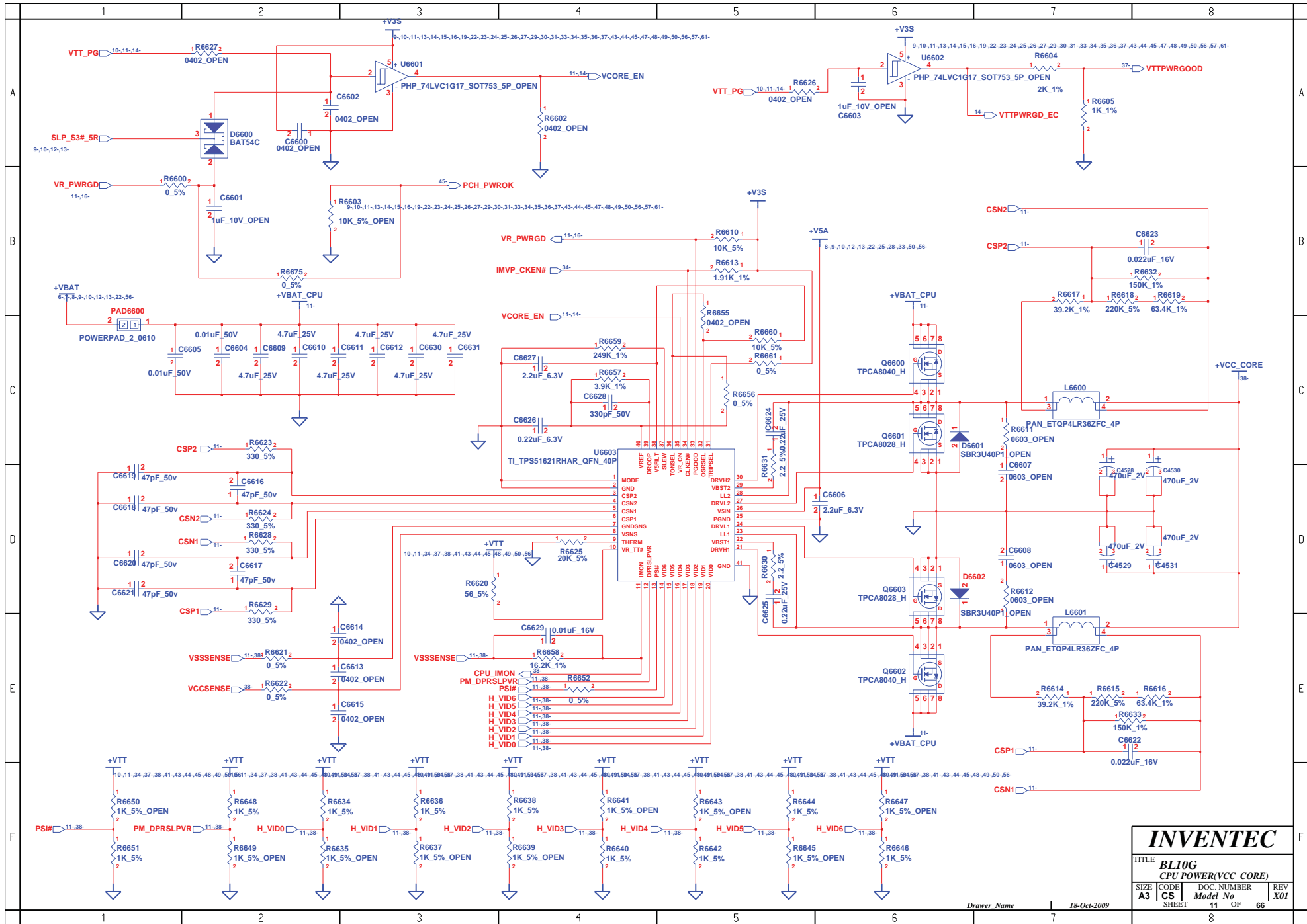

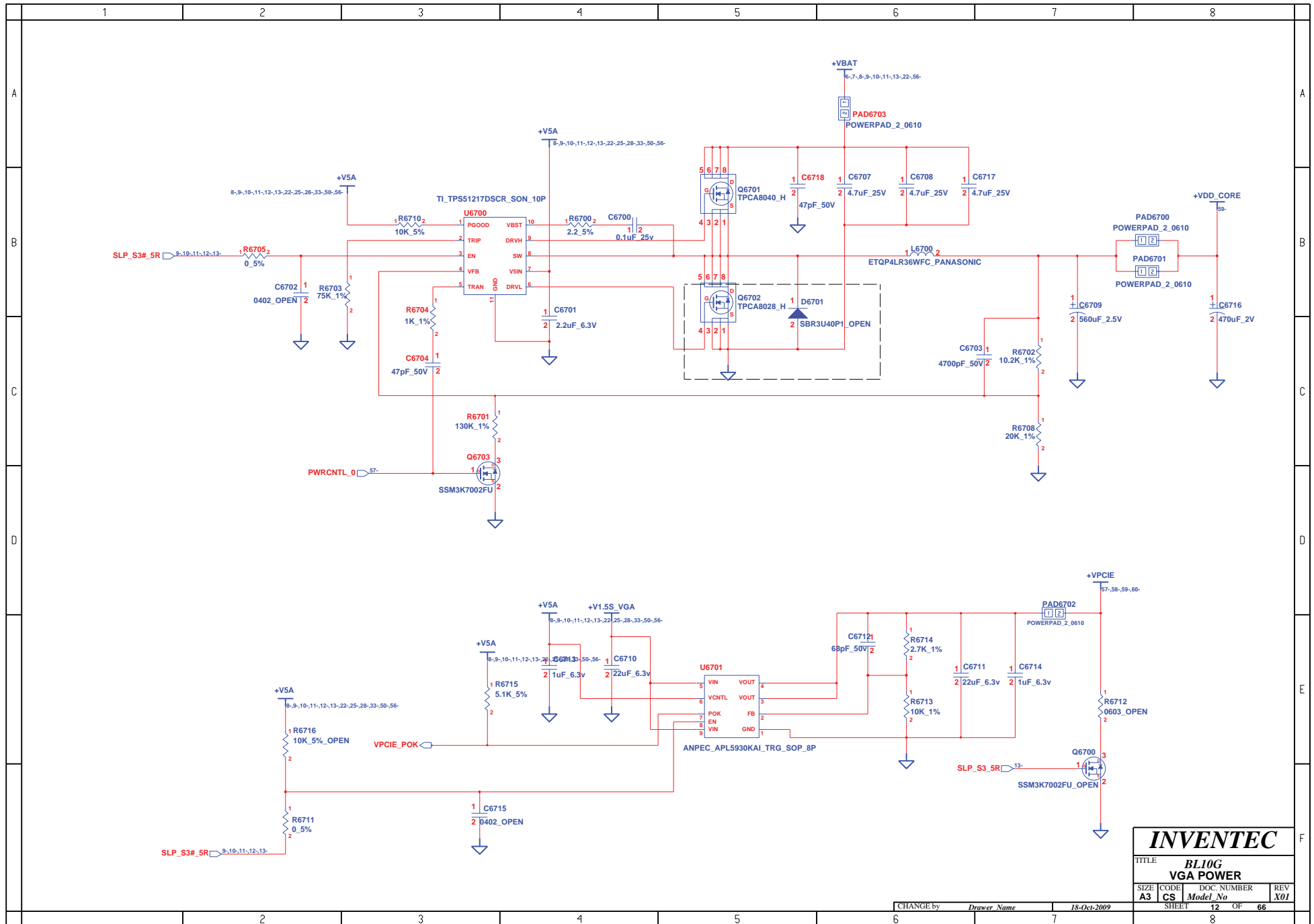

<b>INVENTEC</b>			
TITLE <b>BL10G</b>			
VGA POWER			
SIZE	CODE	DOC. NUMBER	REV
A3	CS	Model No	X01
CHANGE by		Drawer Name	18-Oct-2009
SHEET		12	OF 66
		8	

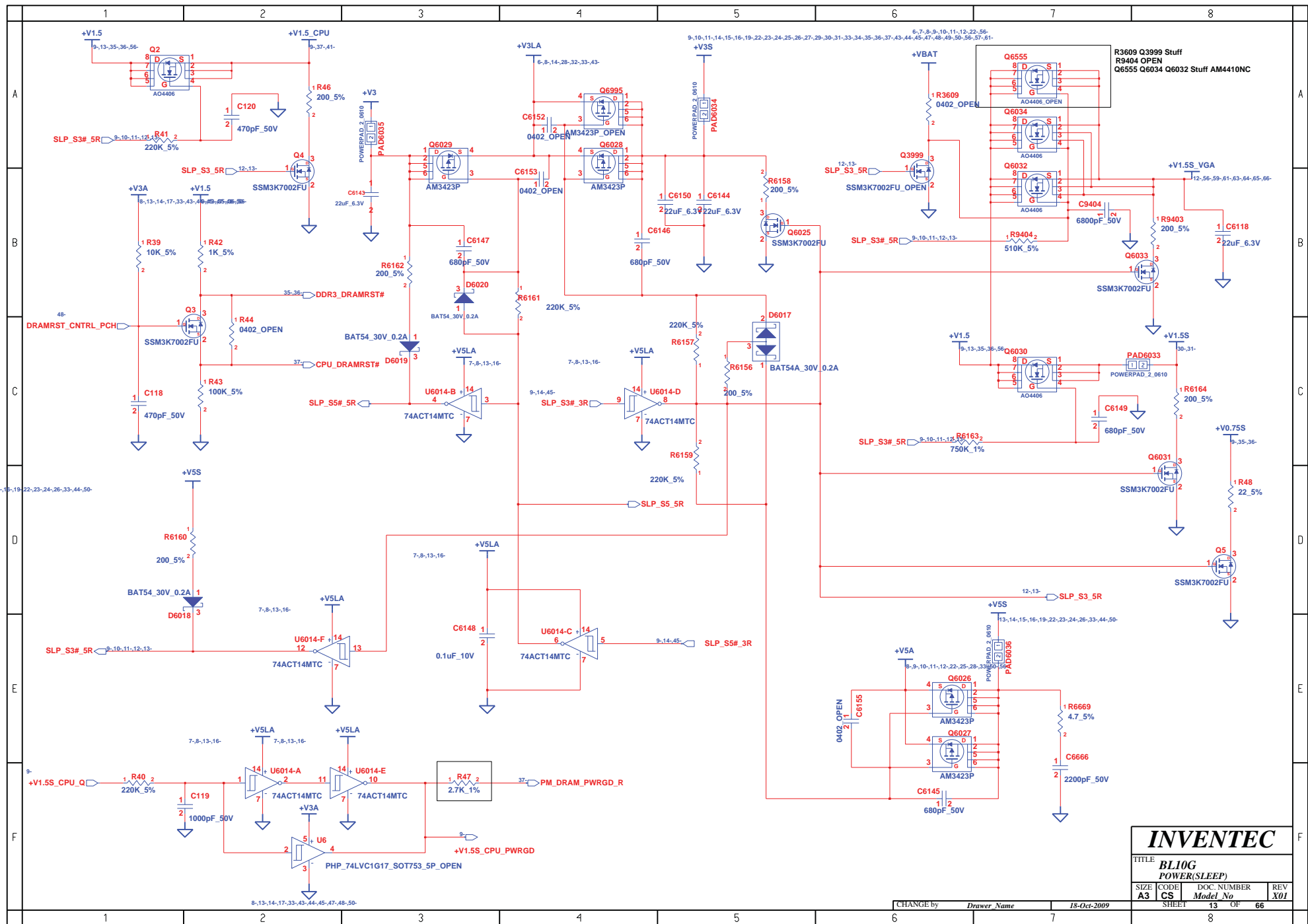

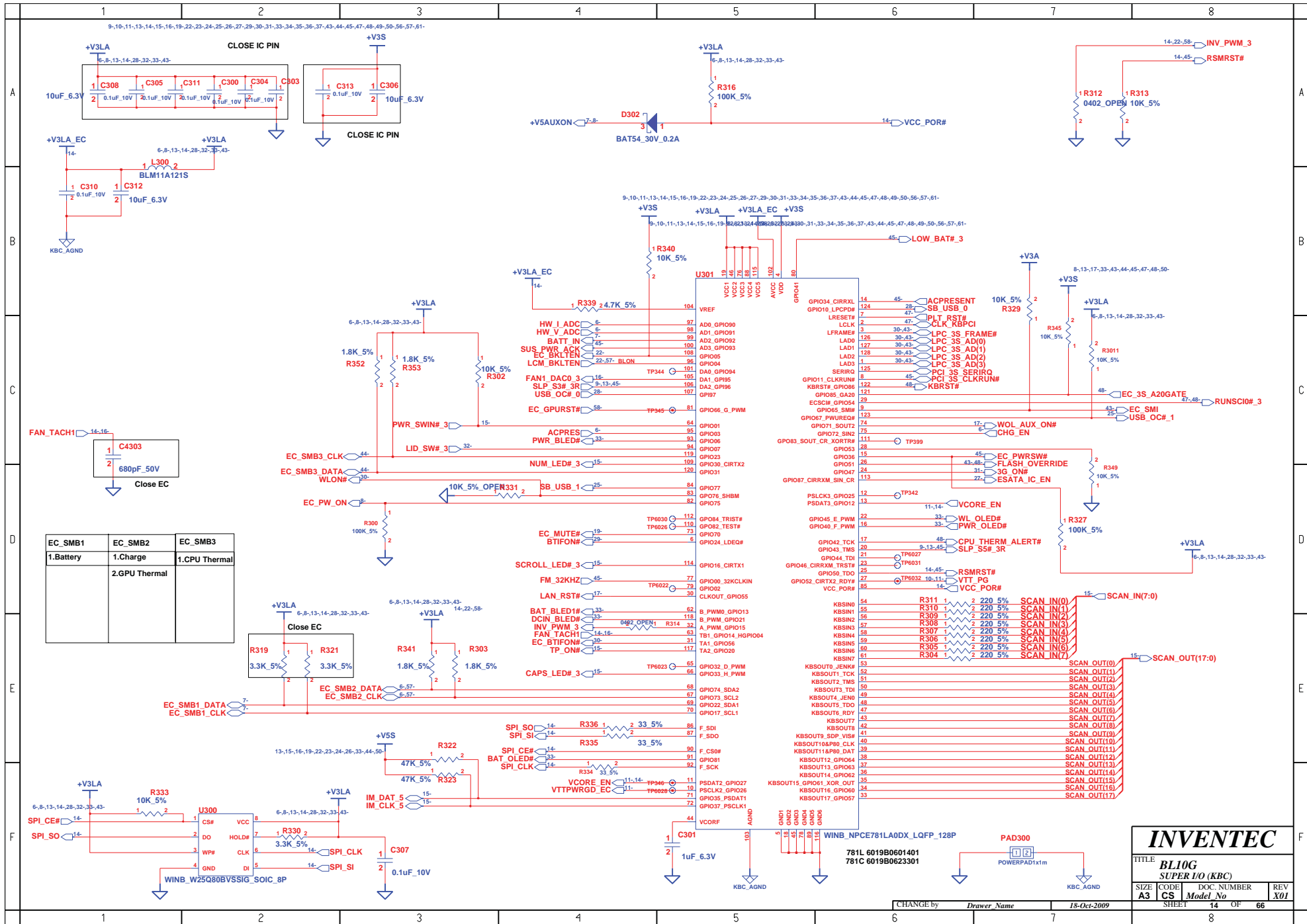

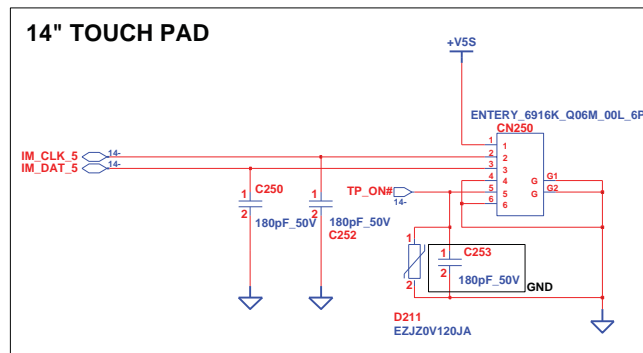
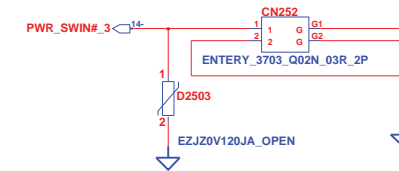
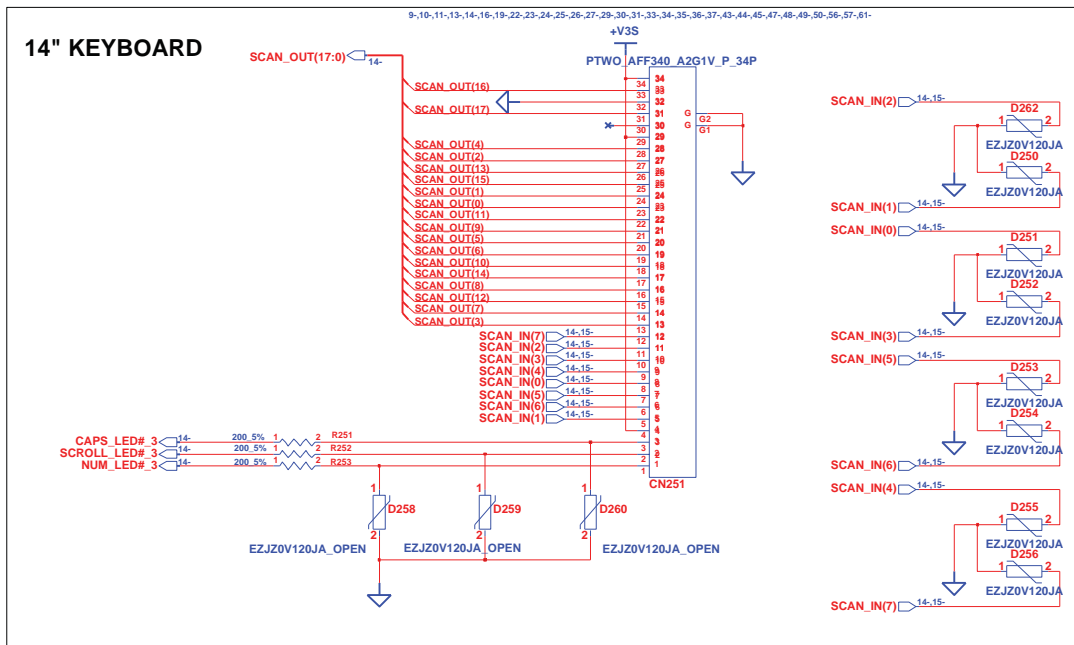

**INVENTEC**

TITLE			
BL10G			
K/B & TP/B CONN			
SIZE	CODE	DOC. NUMBER	REV
A3	CS	Model No	X01
CHANGE by		Drawer Name	18-Oct-2009
SHEET		15	OF 66

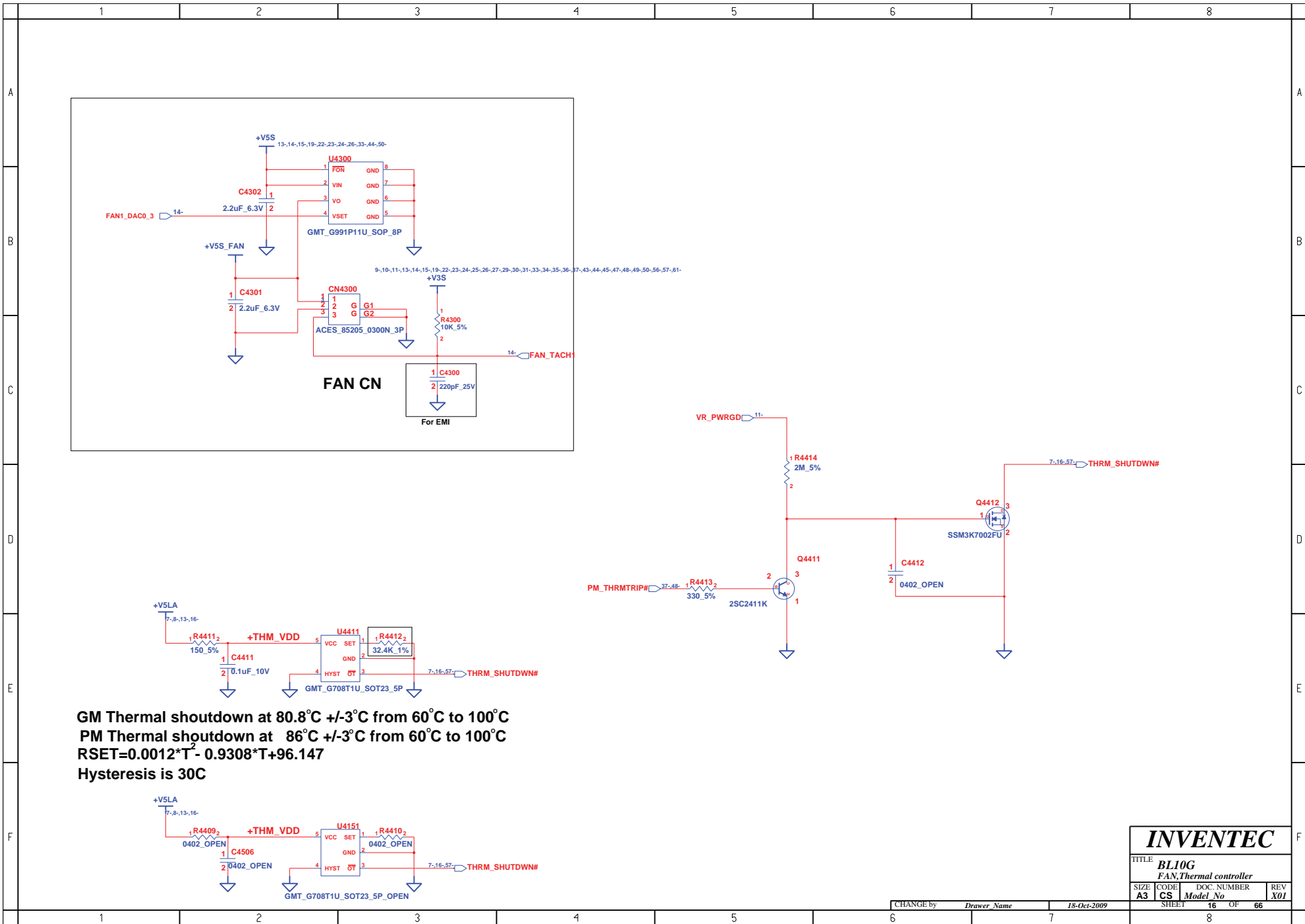

# INVENTEC

TITLE			
BLI0G			
FAN,Thermal controller			
SIZE	CODE	DOC. NUMBER	REV
A3	CS	Model No	X01
SHEET		OF	
16		66	

CHANGE by *Drawer Name* 18-Oct-2009





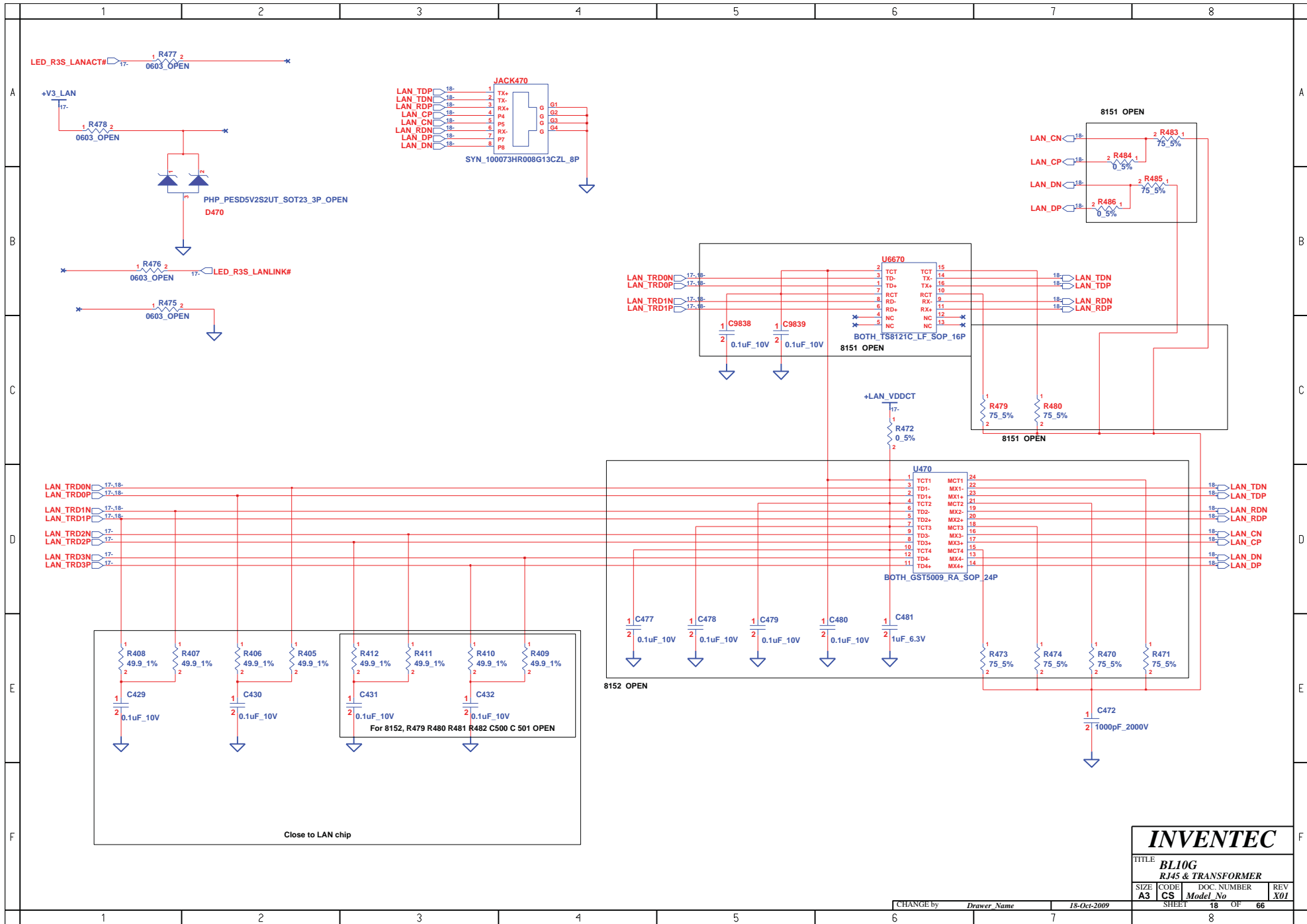

<b>INVENTEC</b>			
TITLE: <b>BLI0G</b>			
RJ45 & TRANSFORMER			
SIZE: <b>A3</b>	CODE: <b>CS</b>	DOC. NUMBER: <b>Model No</b>	REV: <b>X01</b>
CHANGE by: <i>Drawer Name</i>		18-Oct-2009	SHEET 18 OF 66

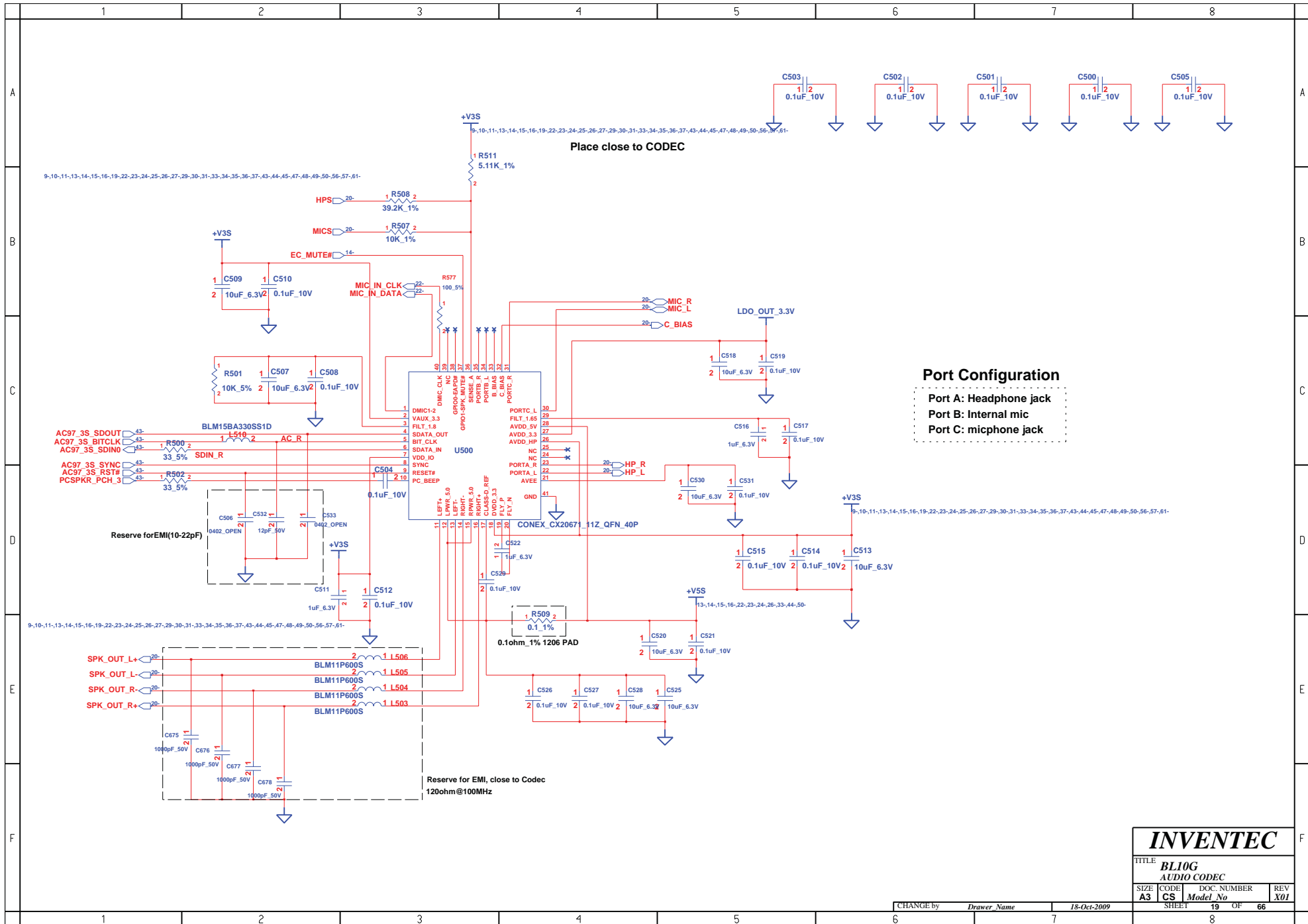

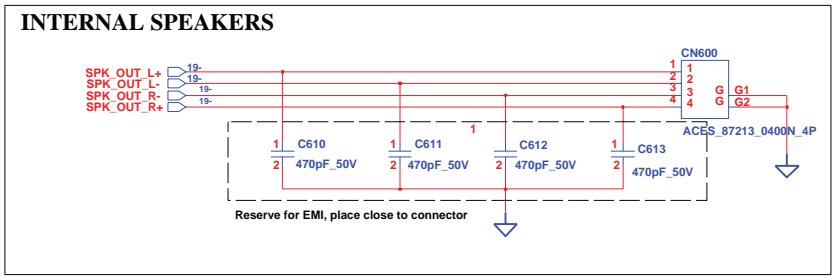

## AUDIO JACKS

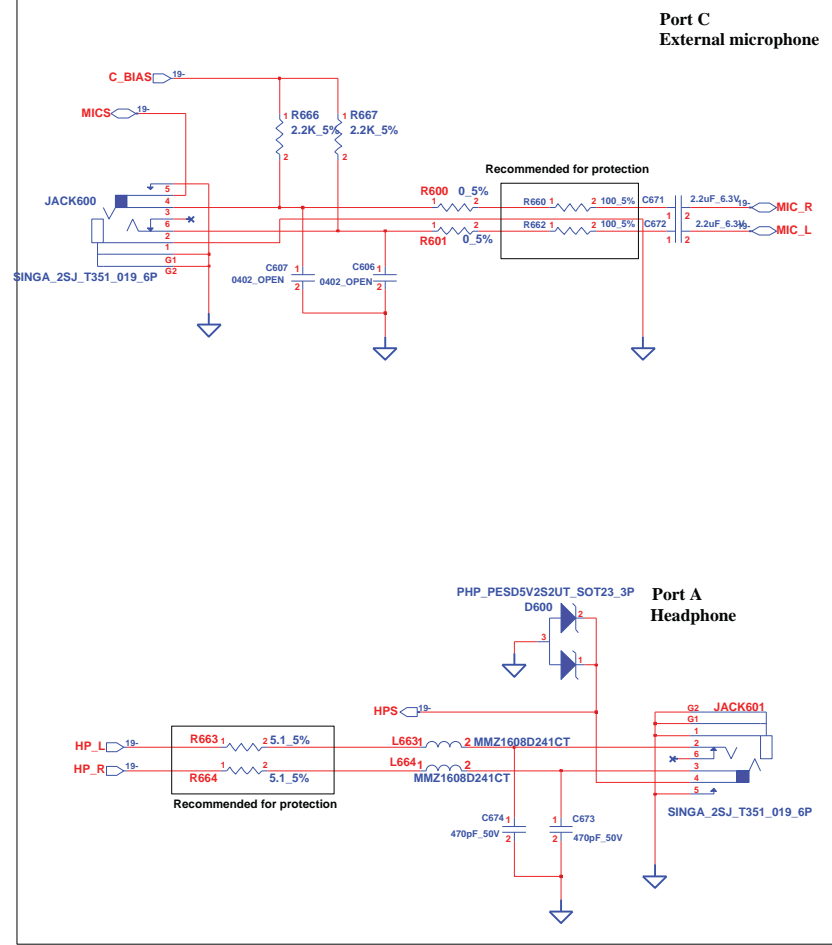

<b>INVENTEC</b>			
TITLE <b>BLI0G</b>			
AUDIO AMP&MIC&SPEAKER			
SIZE <b>A3</b>	CODE <b>CS</b>	DOC NUMBER Model No	REV <b>X01</b>
CHANGE by Drawer Name		18-Oct-2009	SHEET 20 OF 66

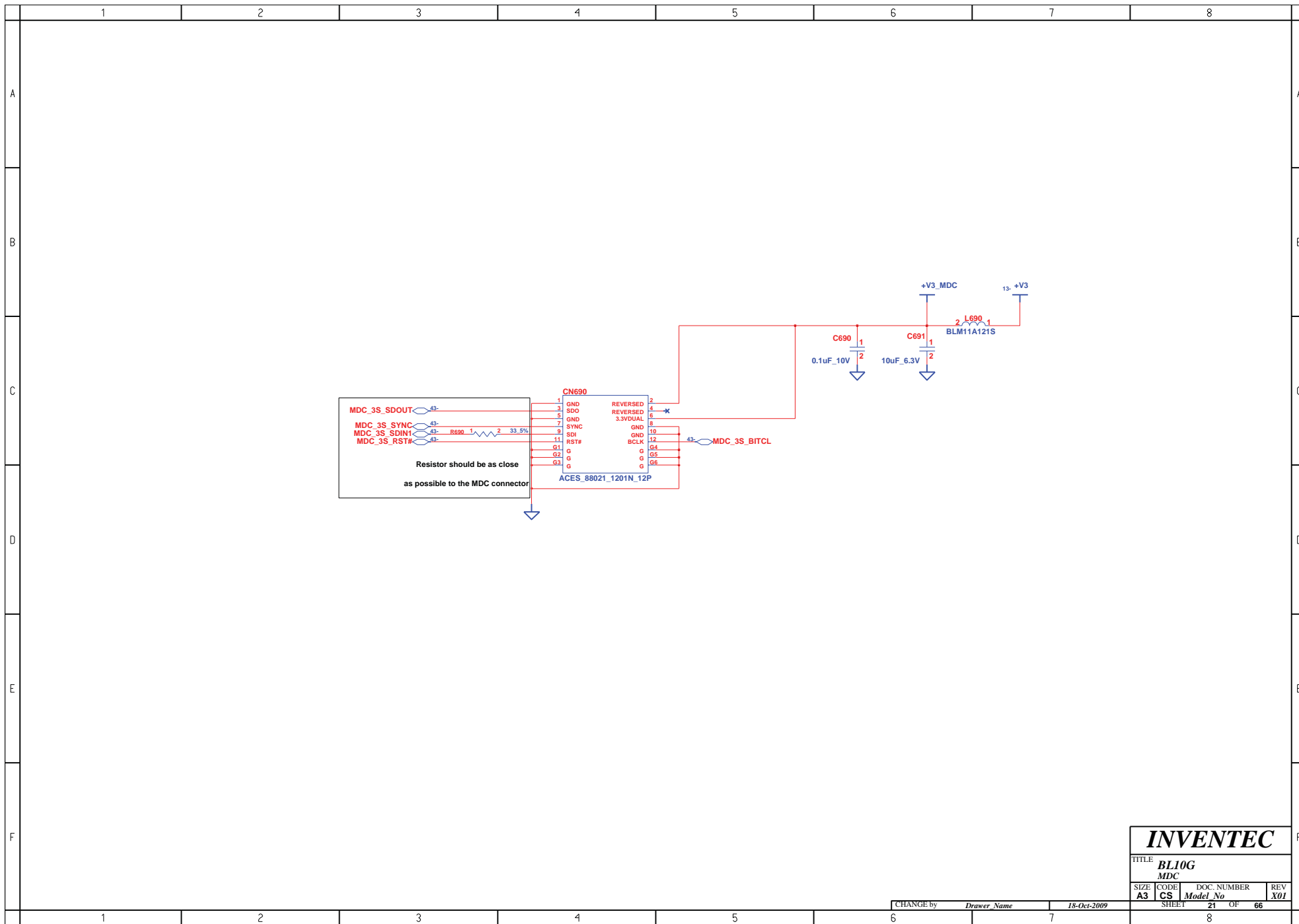

<b>INVENTEC</b>			
TITLE			
<b>BL10G</b>			
<b>MDC</b>			
SIZE	CODE	DOC. NUMBER	REV
<b>A3</b>	<b>CS</b>	<i>Model No</i>	<b>X01</b>
CHANGE by		18-Oct-2009	
DRAWER Name			
SHEET		21	OF 66
		8	

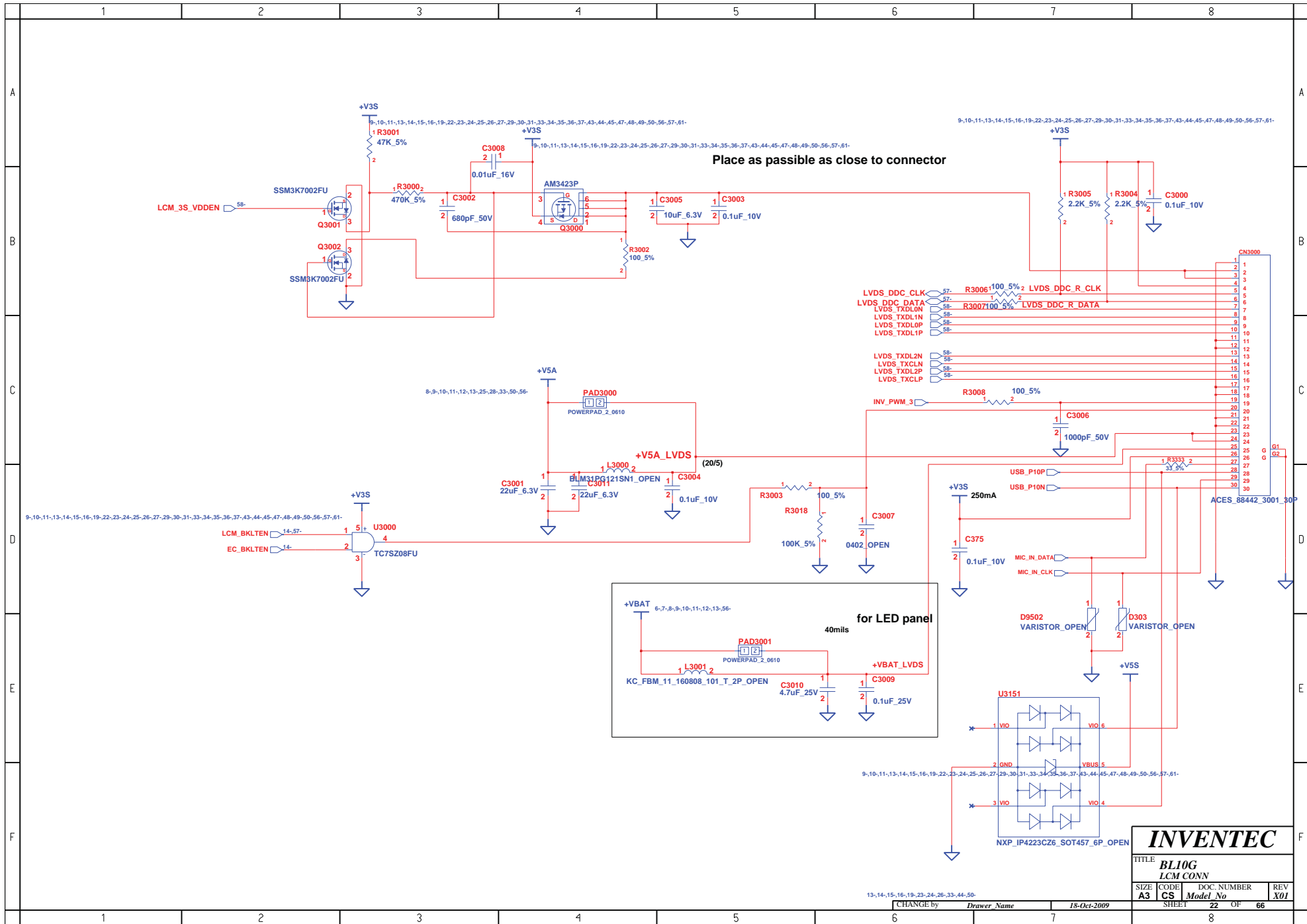

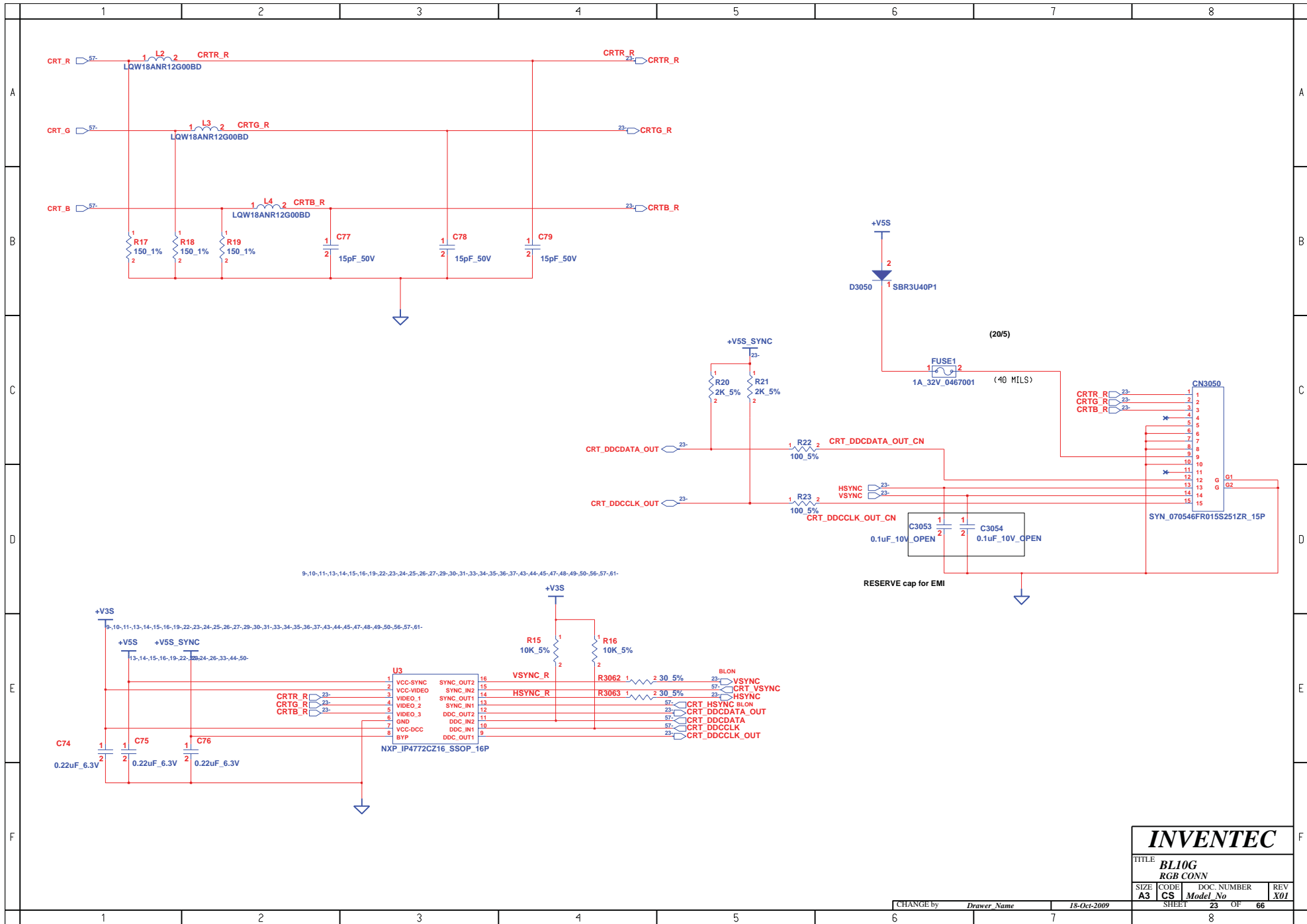

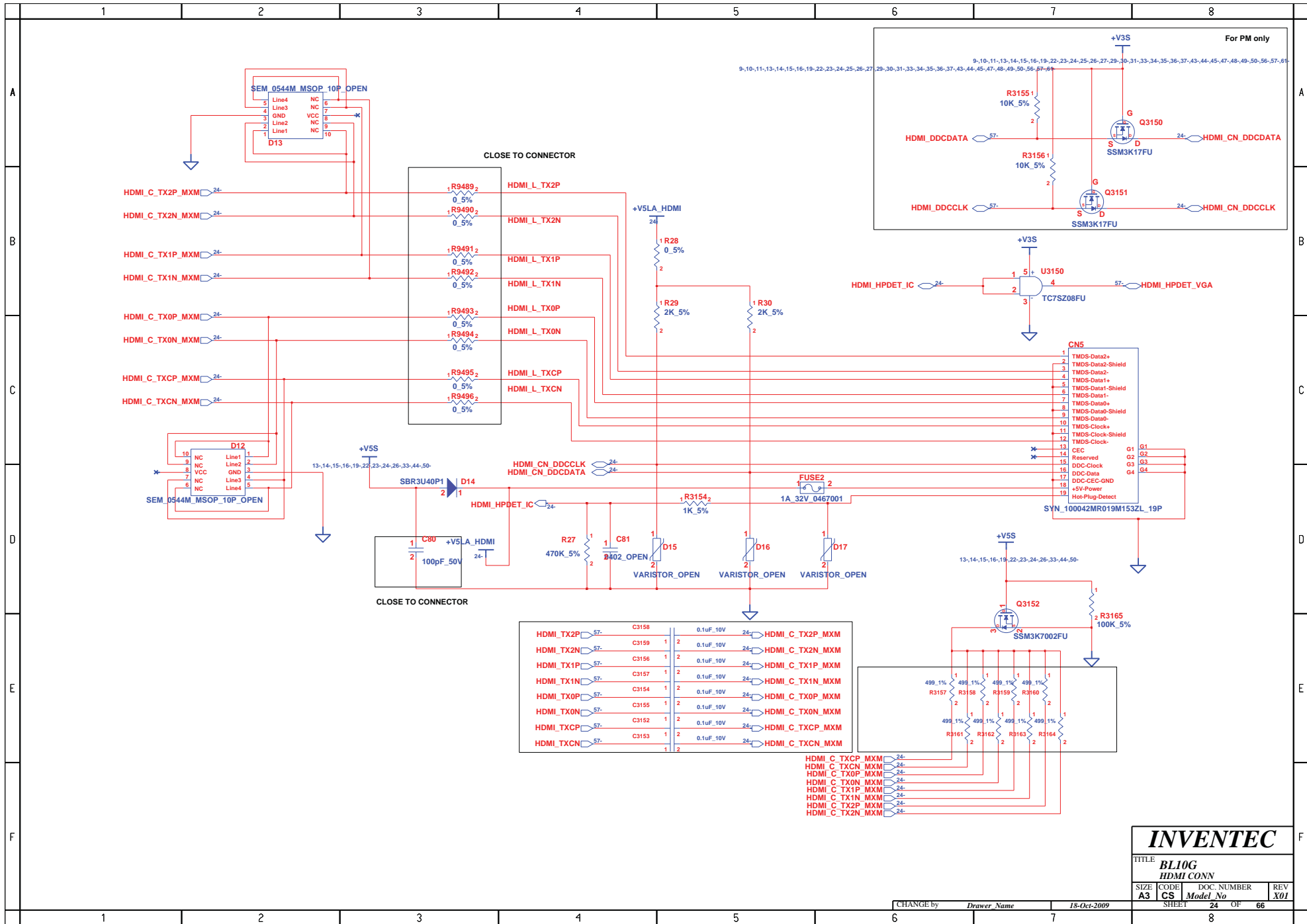

**INVENTEC**

TITLE  
BL10G  
HDMI CONN

SIZE A3	CODE CS	DOC NUMBER Model No	REV X01
------------	------------	------------------------	------------

CHANGE by *Drawer Name* 18-Oct-2009 SHEET 24 OF 66



### CardReader/USB Connector

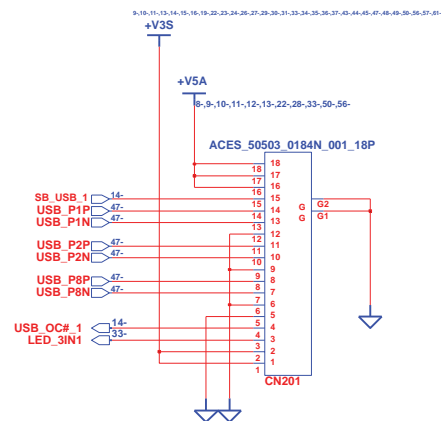

<b>INVENTEC</b>			
TITLE			
<b>BL10G</b>			
<i>Cardreader</i>			
SIZE	CODE	DOC. NUMBER	REV
<b>A3</b>	<b>CS</b>	<i>Model No</i>	<b>X01</b>
CHANGE by		18-Oct-2009	
DRAWER Name			
SHEET		25	OF 66
		8	

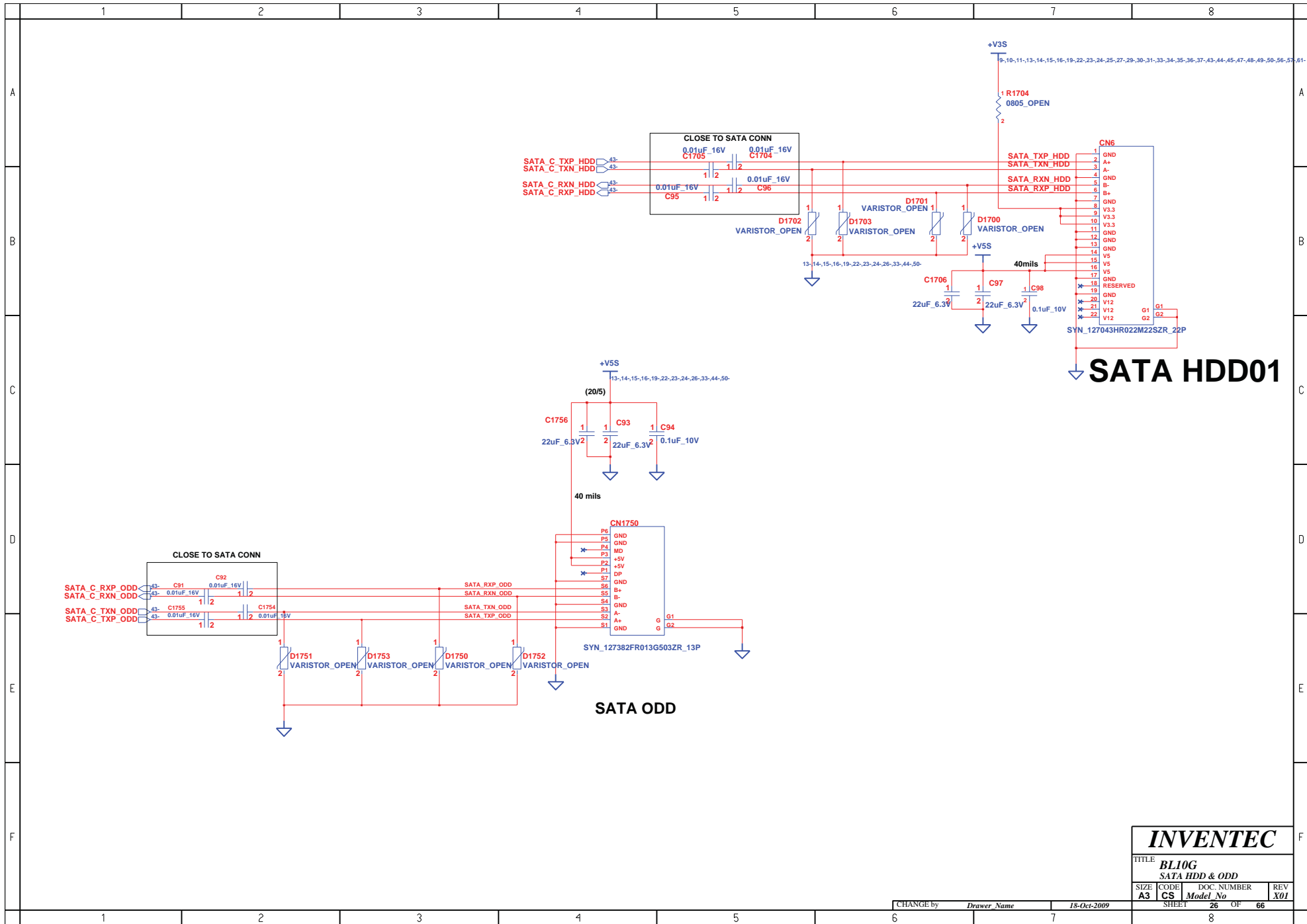

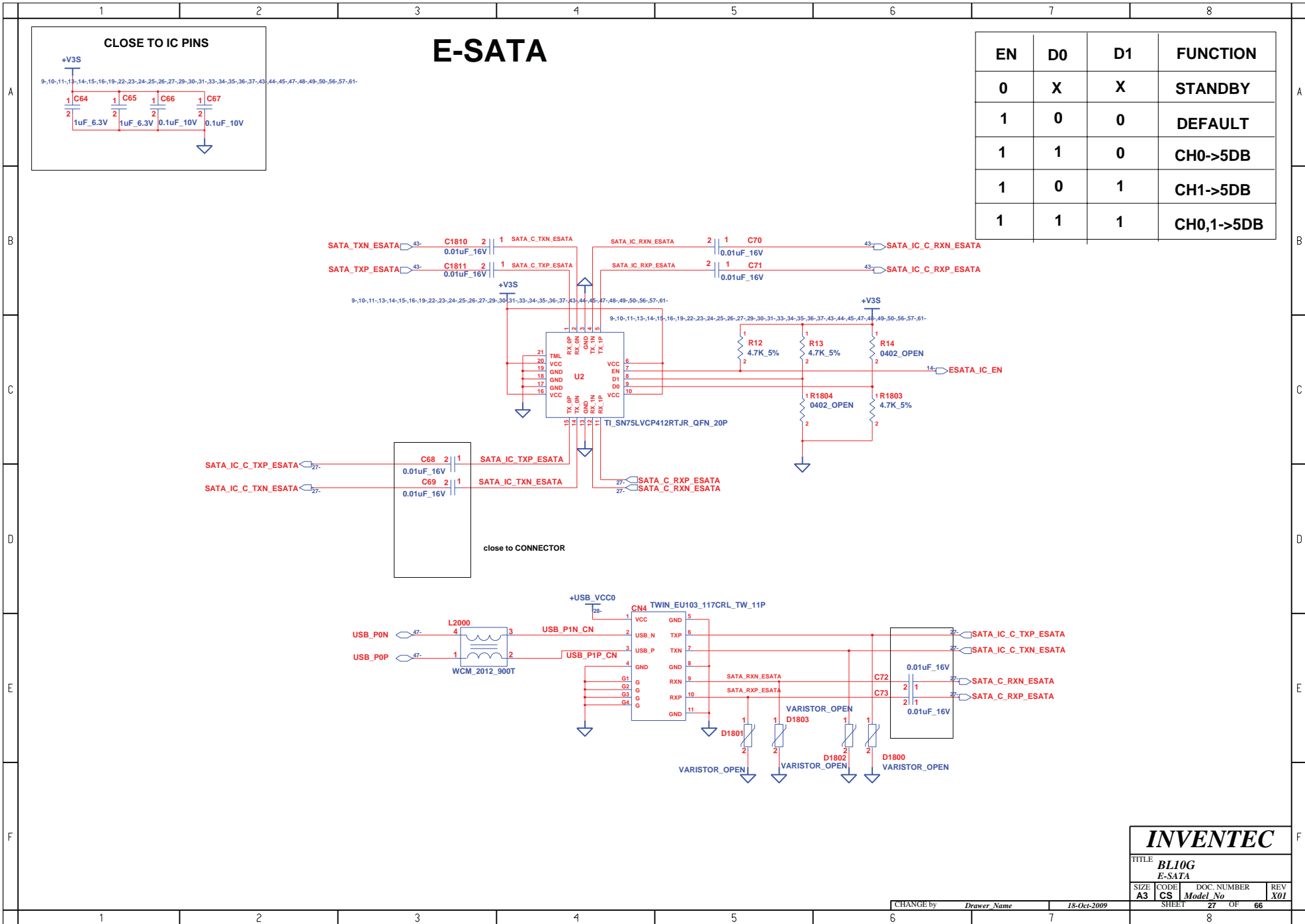

<b>INVENTEC</b>			
TITLE <b>BL10G</b> E-SATA			
SIZE <b>A3</b>	CODE <b>CS</b>	DOC. NUMBER Model No	REV <b>X01</b>
CHANGE by <i>Drawer Name</i>		18-Oct-2009	SHEET 27 OF 66

# ESATA Port

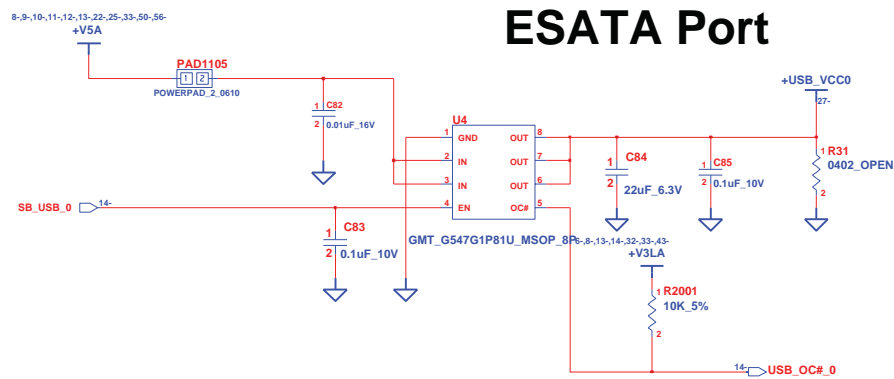

<b>INVENTEC</b>			
TITLE <b>BL10G</b> USB CONN			
SIZE <b>A3</b>	CODE <b>CS</b>	DOC. NUMBER Model No	REV <b>X01</b>
CHANGE by Drawer Name		18-Oct-2009	SHEET 28 OF 66

# BLUETOOTH

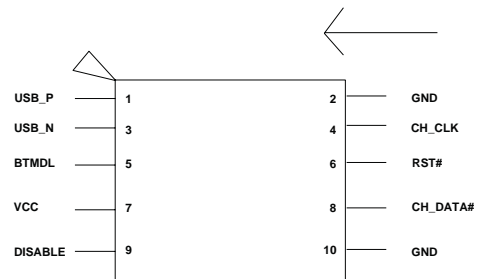
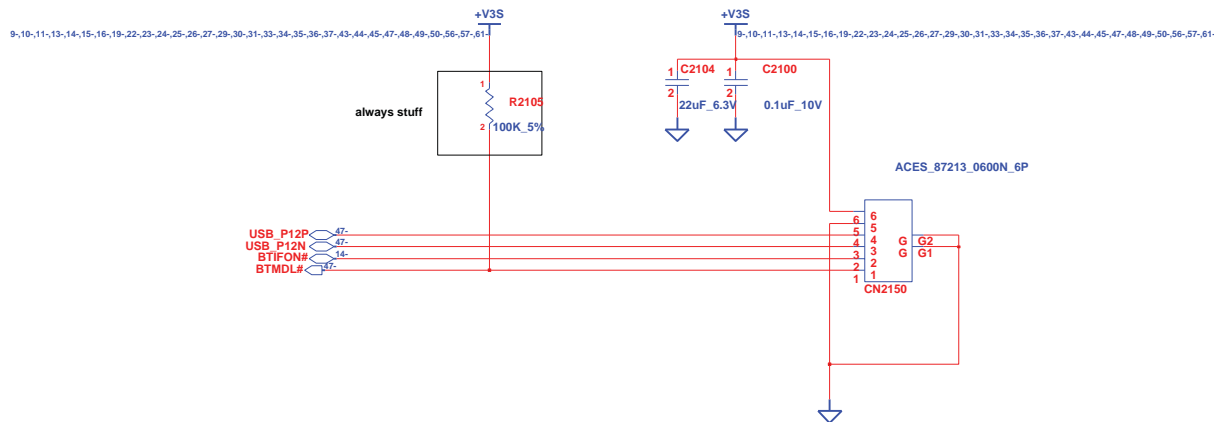

<b>INVENTEC</b>			
TITLE <b>BL10G</b> Bluetooth			
SIZE <b>A3</b>	CODE <b>CS</b>	DOC. NUMBER Model No	REV <b>X01</b>
CHANGE by Drawer Name		18-Oct-2009	SHEET 29 OF 66
1	2	3	8



# 3G/GPS

9-10-11-13-14-15-16-19-22-23-24-25-26-27-29-30-31-33-34-35-36-37-43-44-45-47-48-49-50-56-57-61- 13-30-

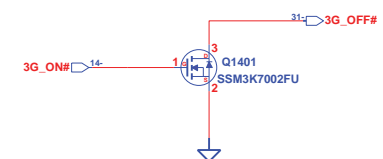
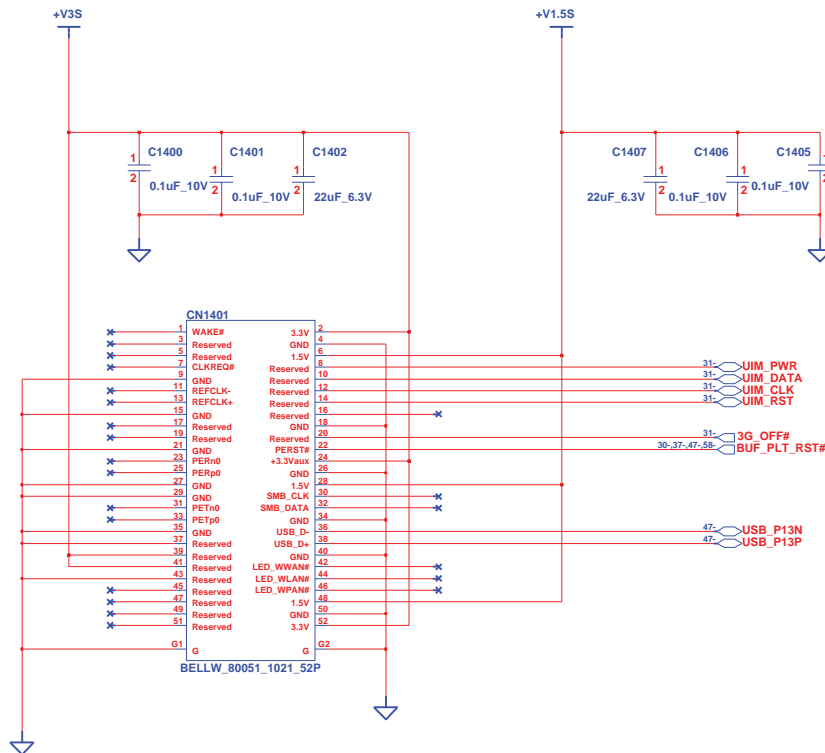

9-10-11-13-14-15-16-19-22-23-24-25-26-27-29-30-31-33-34-35-36-37-43-44-45-47-48-49-50-56-57-61-

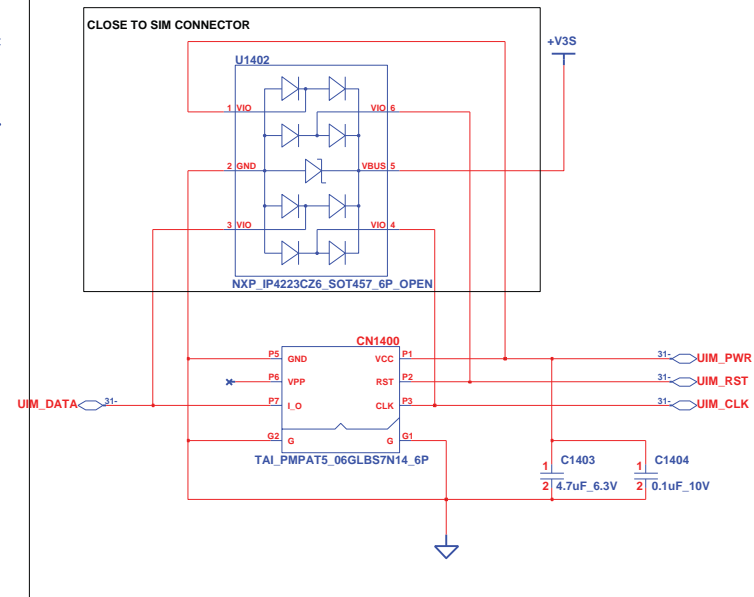

# MINI CARD 2

**INVENTEC**

TITLE  
**BL10G**

SIZE <b>A3</b>	CODE <b>CS</b>	DOC. NUMBER Model No	REV <b>X01</b>
CHANGE by Drawer Name		18-Oct-2009	SHEET 31 OF 66

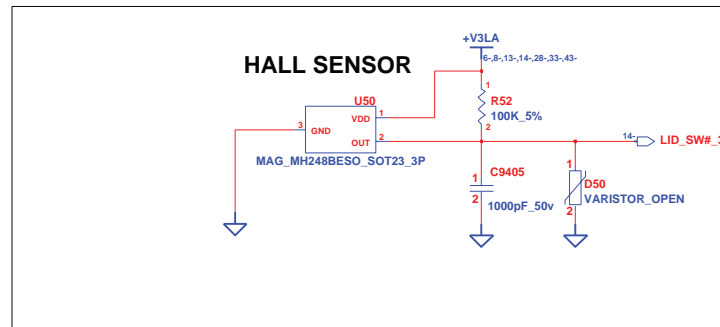

**INVENTEC**

TITLE			
BL10G			
LID SW			
SIZE	CODE	DOC. NUMBER	REV
A3	CS	Model No	X01
SHEET		32 OF	66
		8	

CHANGE by *Drawer Name* 18-Oct-2009



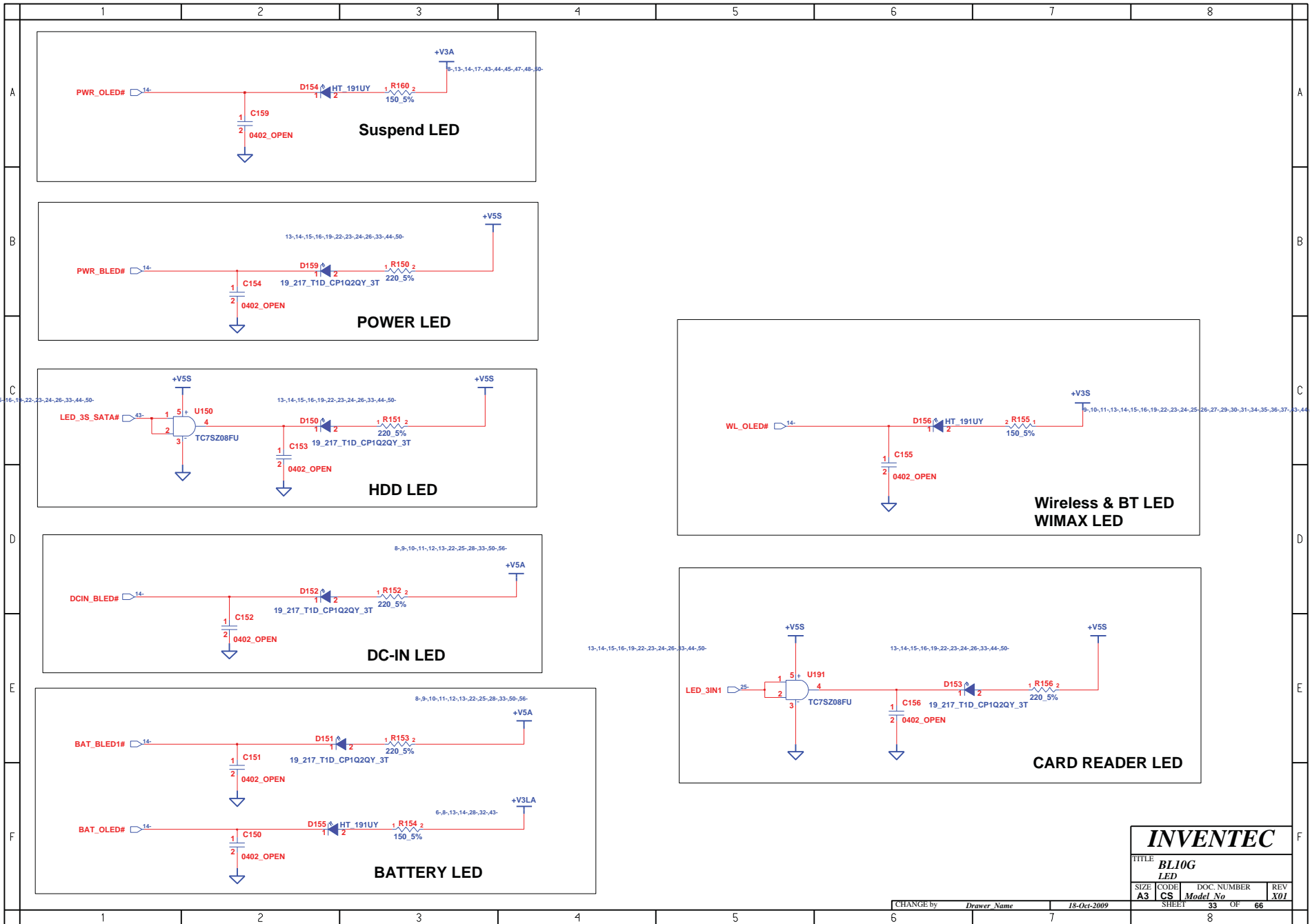

<b>INVENTEC</b>			
TITLE: <b>BL10G</b>			
LED			
SIZE: <b>A3</b>	CODE: <b>CS</b>	DOC. NUMBER: <b>Model No</b>	REV: <b>X01</b>
CHANGE by: <i>Drawer Name</i>		18-Oct-2009	SHEET 33 OF 66
		8	

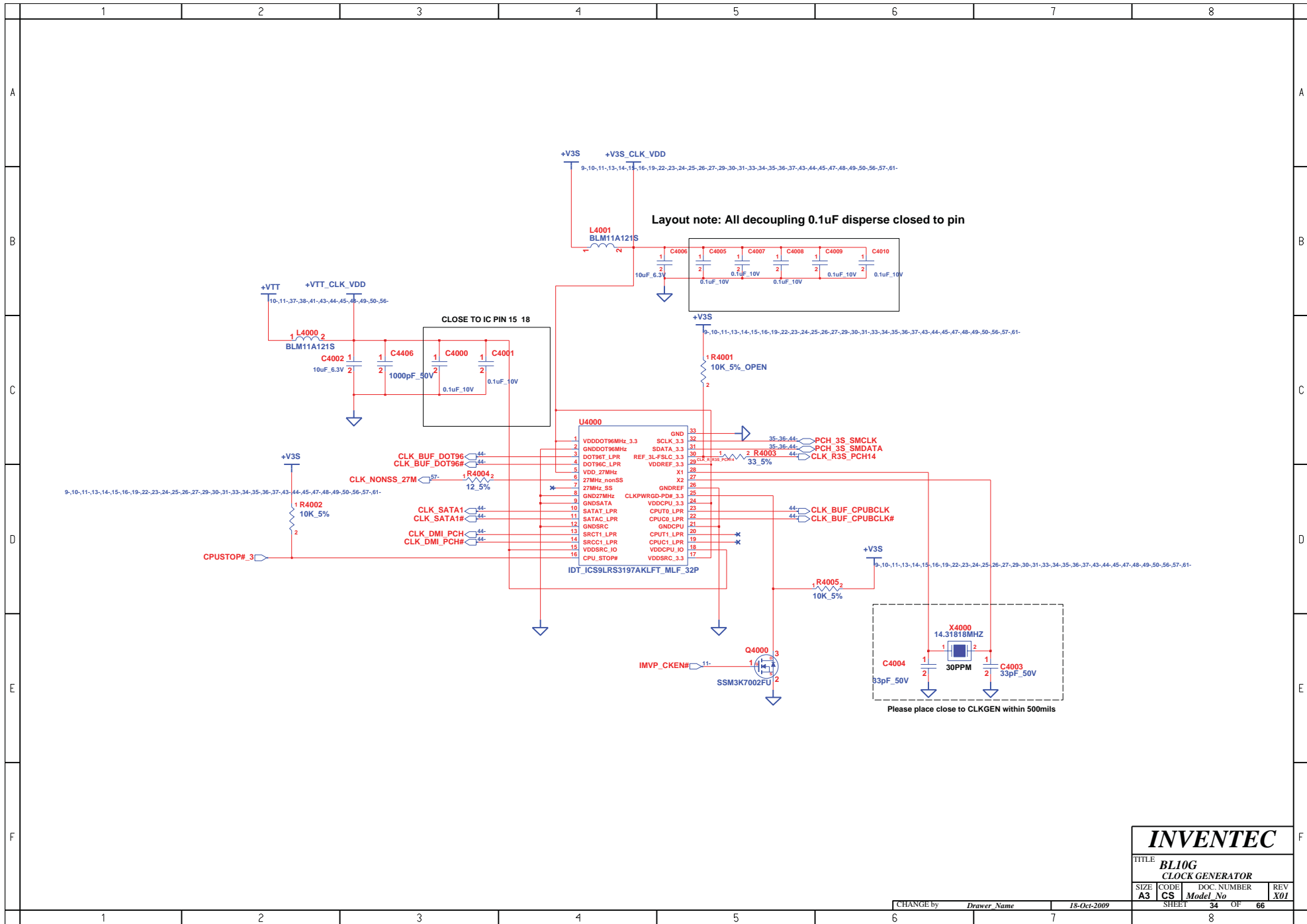

# INVENTEC

TITLE  
**BLI0G**  
**CLOCK GENERATOR**

SIZE <b>A3</b>	CODE <b>CS</b>	DOC NUMBER <i>Model No</i>	REV <b>X01</b>
CHANGE by <i>Drawer Name</i>		18-Oct-2009	SHEET 34 OF 66

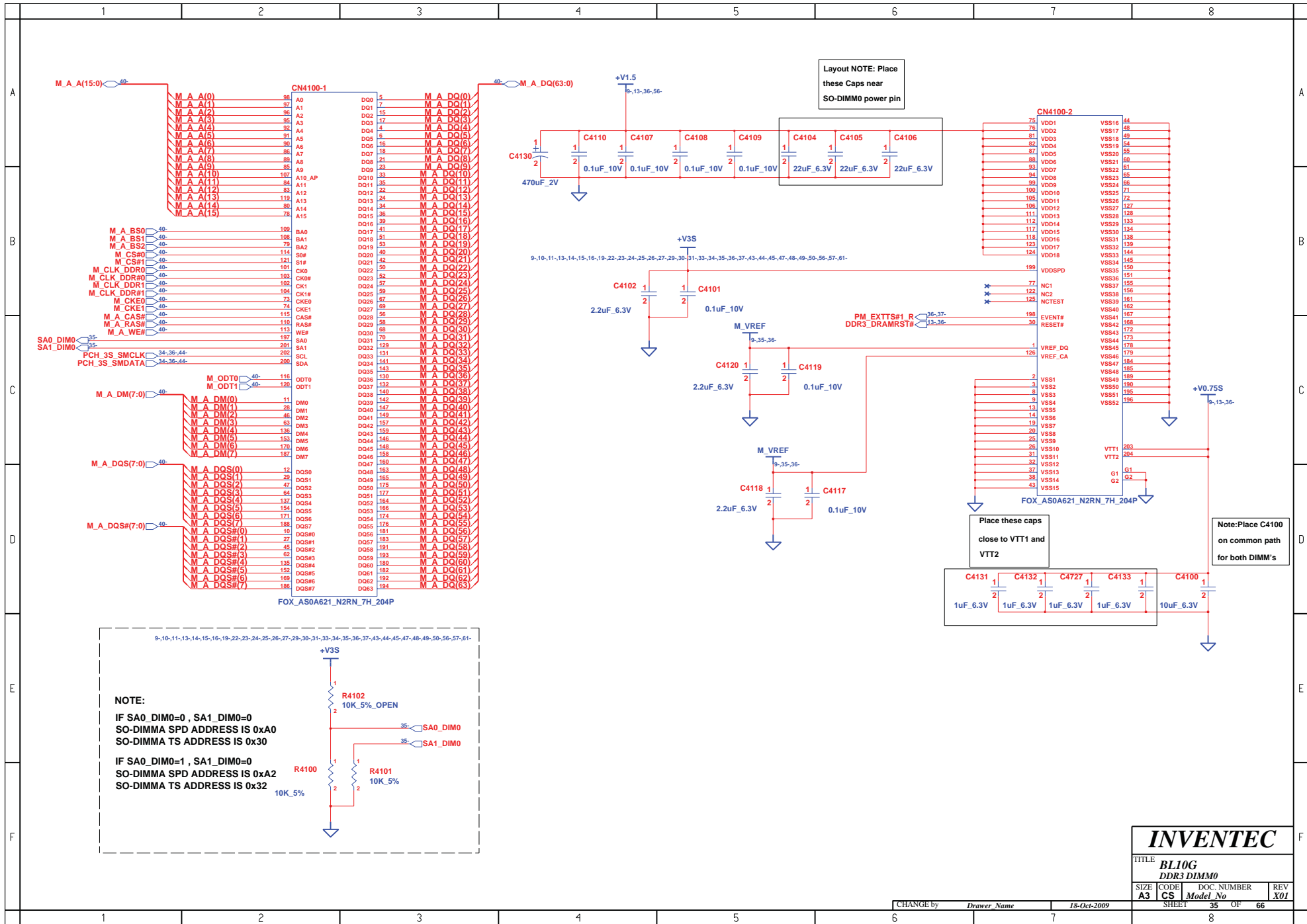

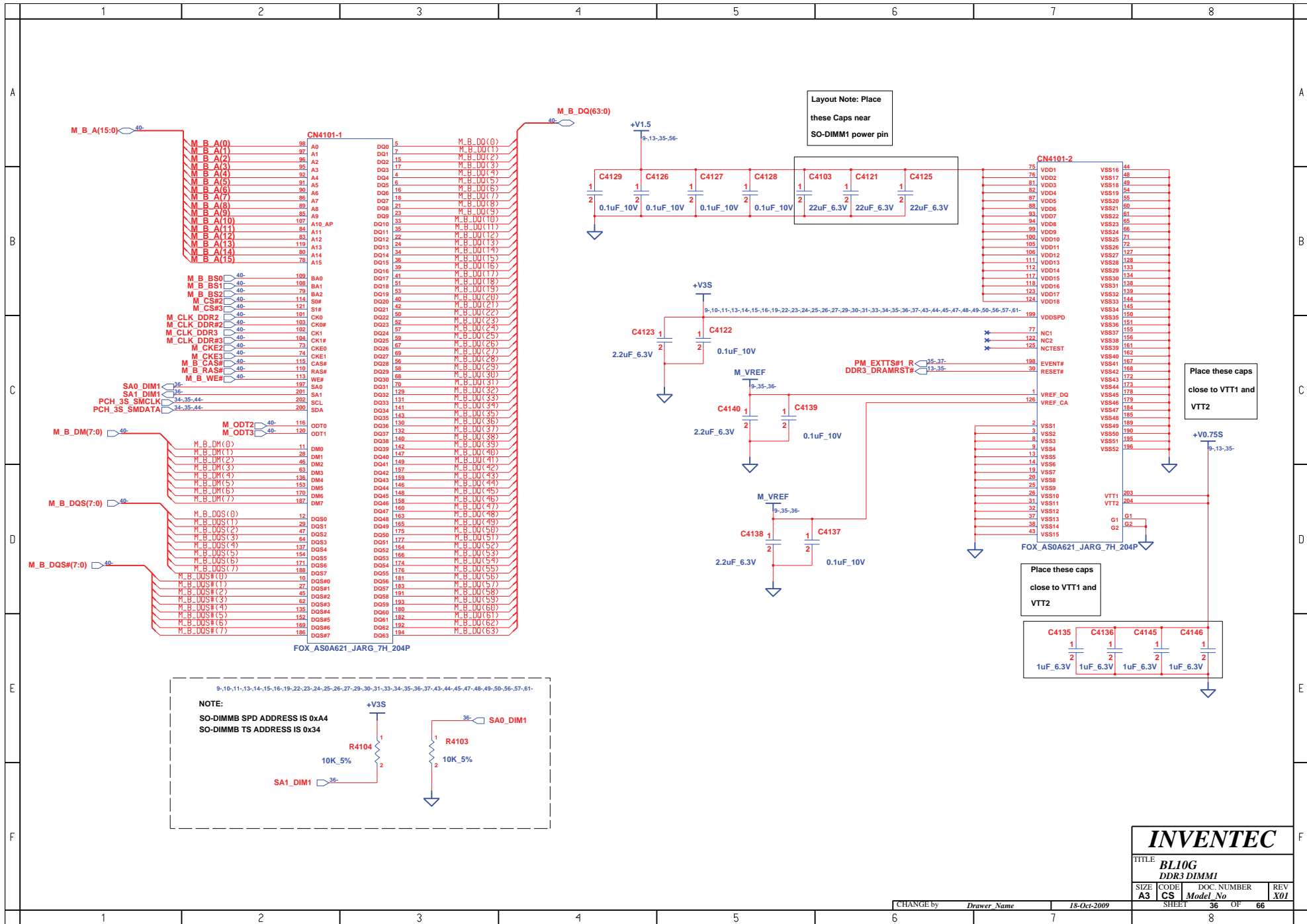

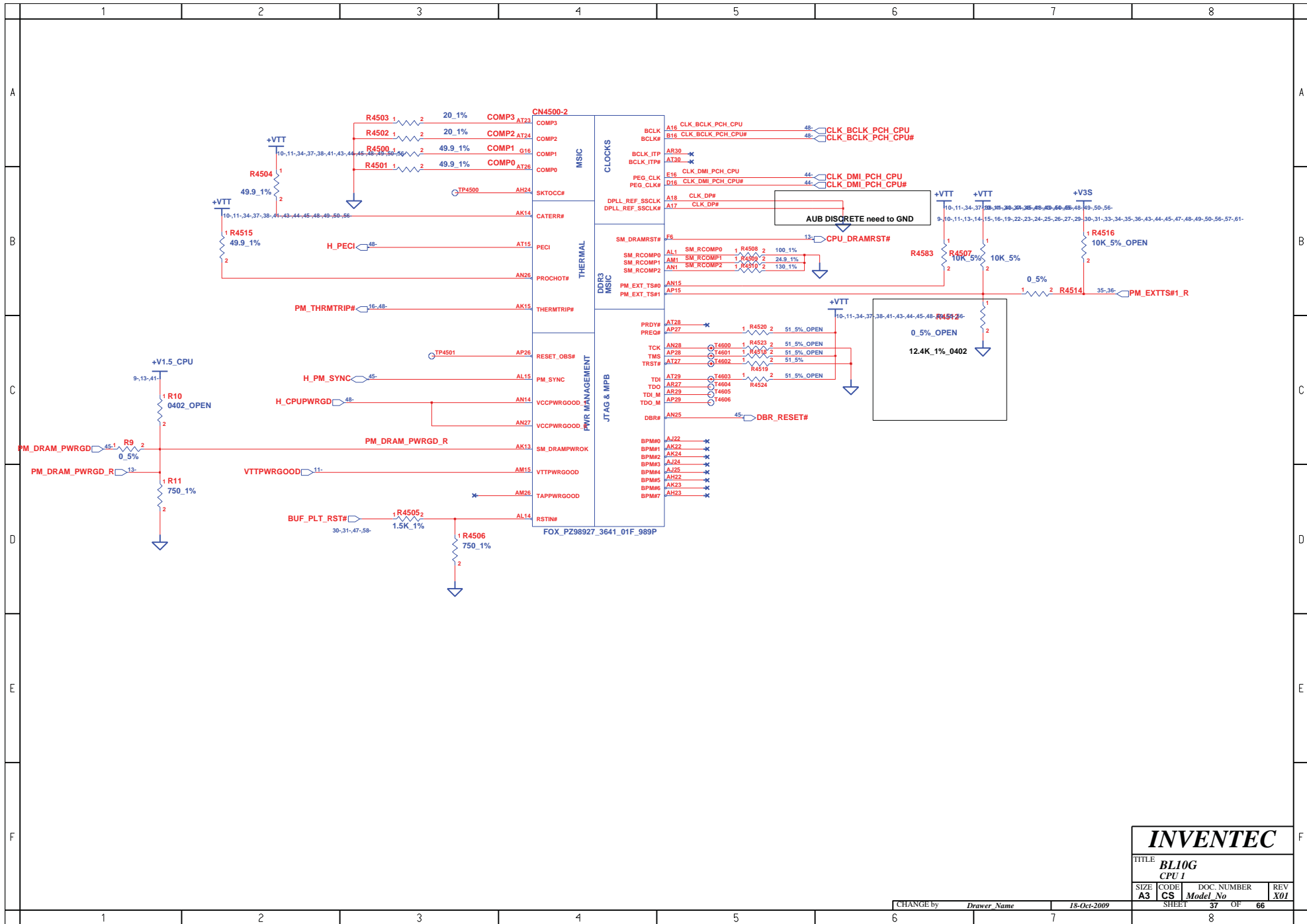

# INVENTEC

TITLE			
BLI0G			
CPU 1			
SIZE	CODE	DOC. NUMBER	REV
A3	CS	Model No	X01
SHEET		37	OF 66

CHANGE by *Drawer Name* 18-Oct-2009

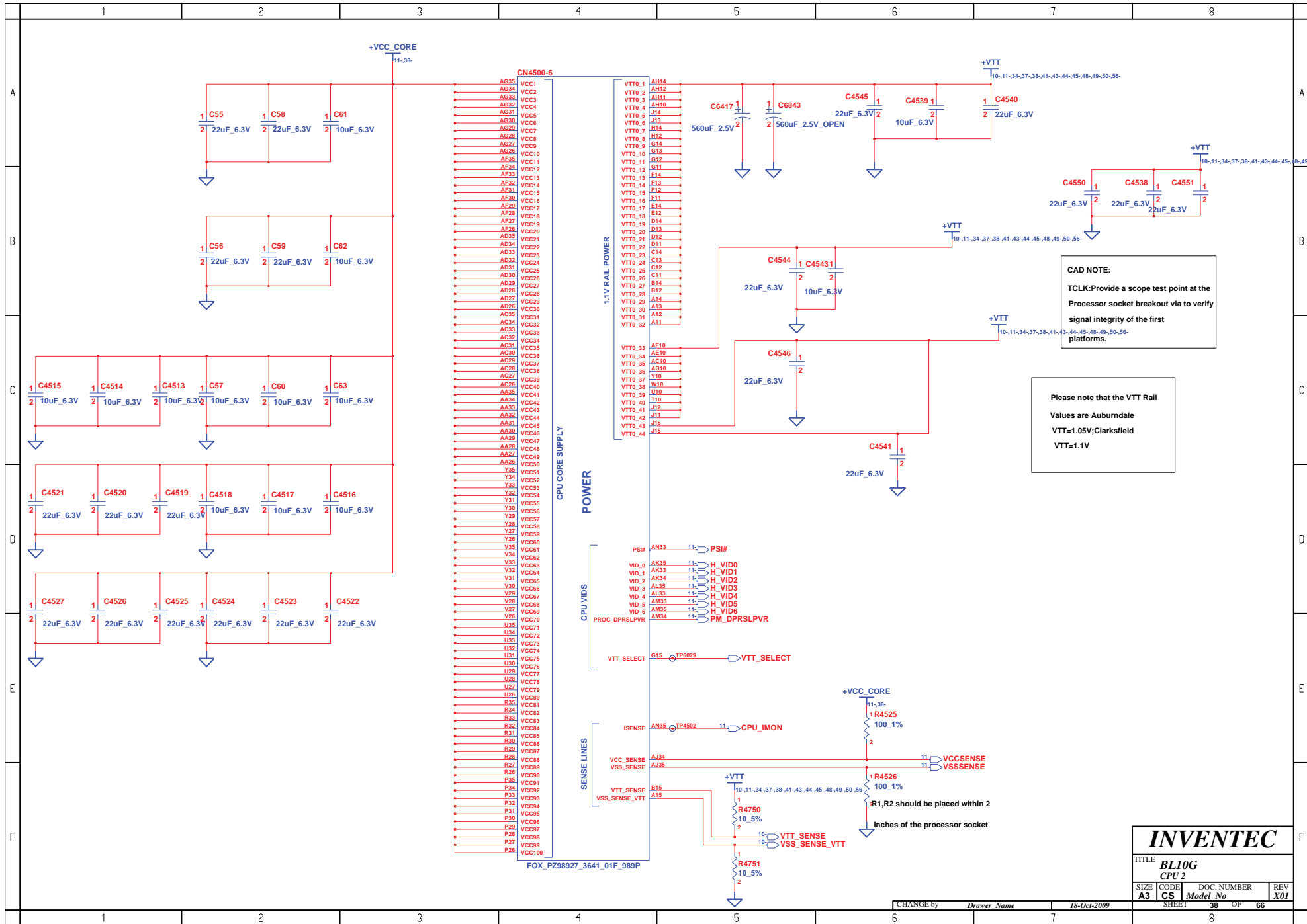

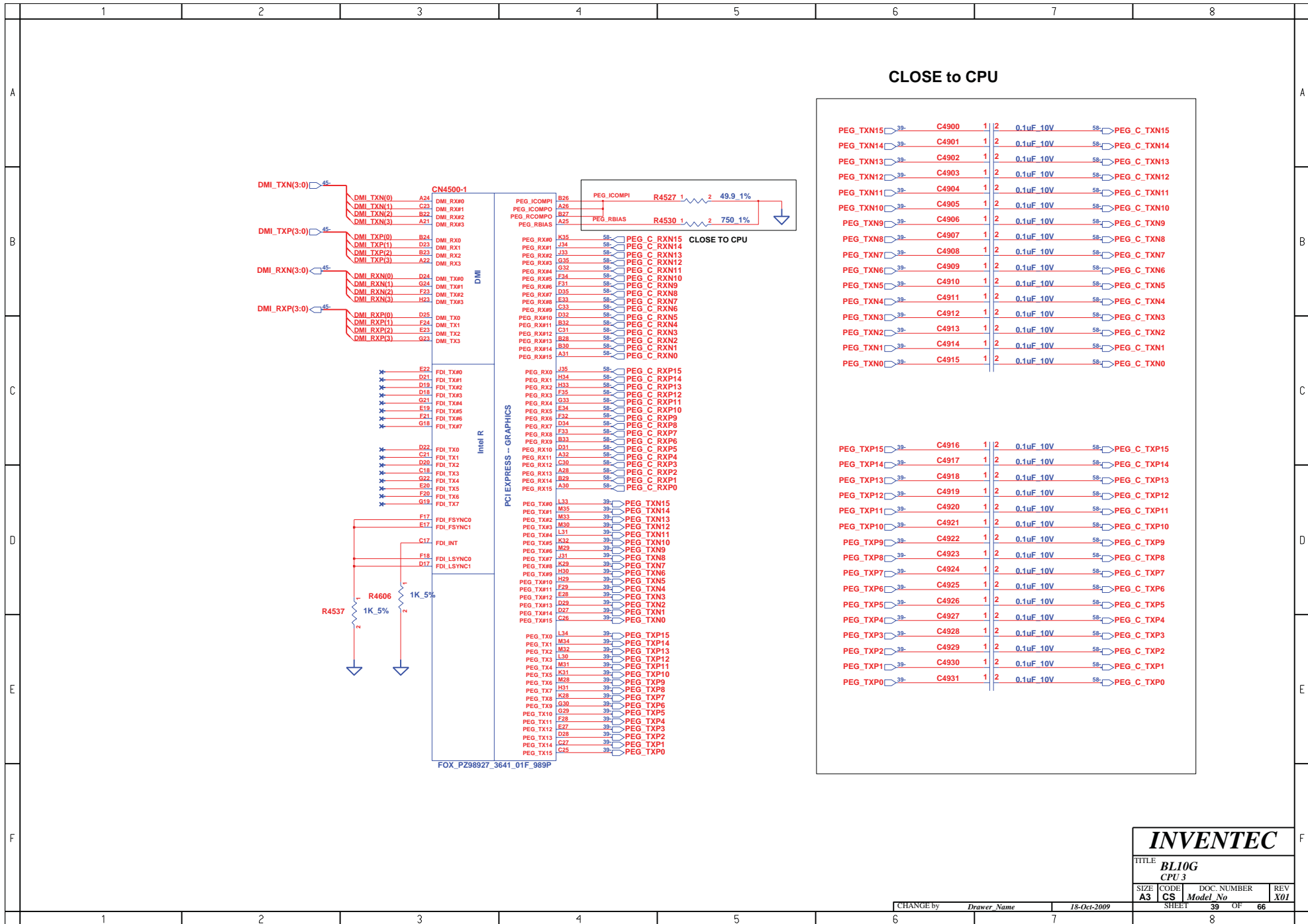

**INVENTEC**

TITLE  
BL10G  
CPU 3

SIZE A3	CODE CS	DOC. NUMBER Model No	REV X01
------------	------------	-------------------------	------------

CHANGE by *Drawer Name* 18-Oct-2009 SHEET 39 OF 66

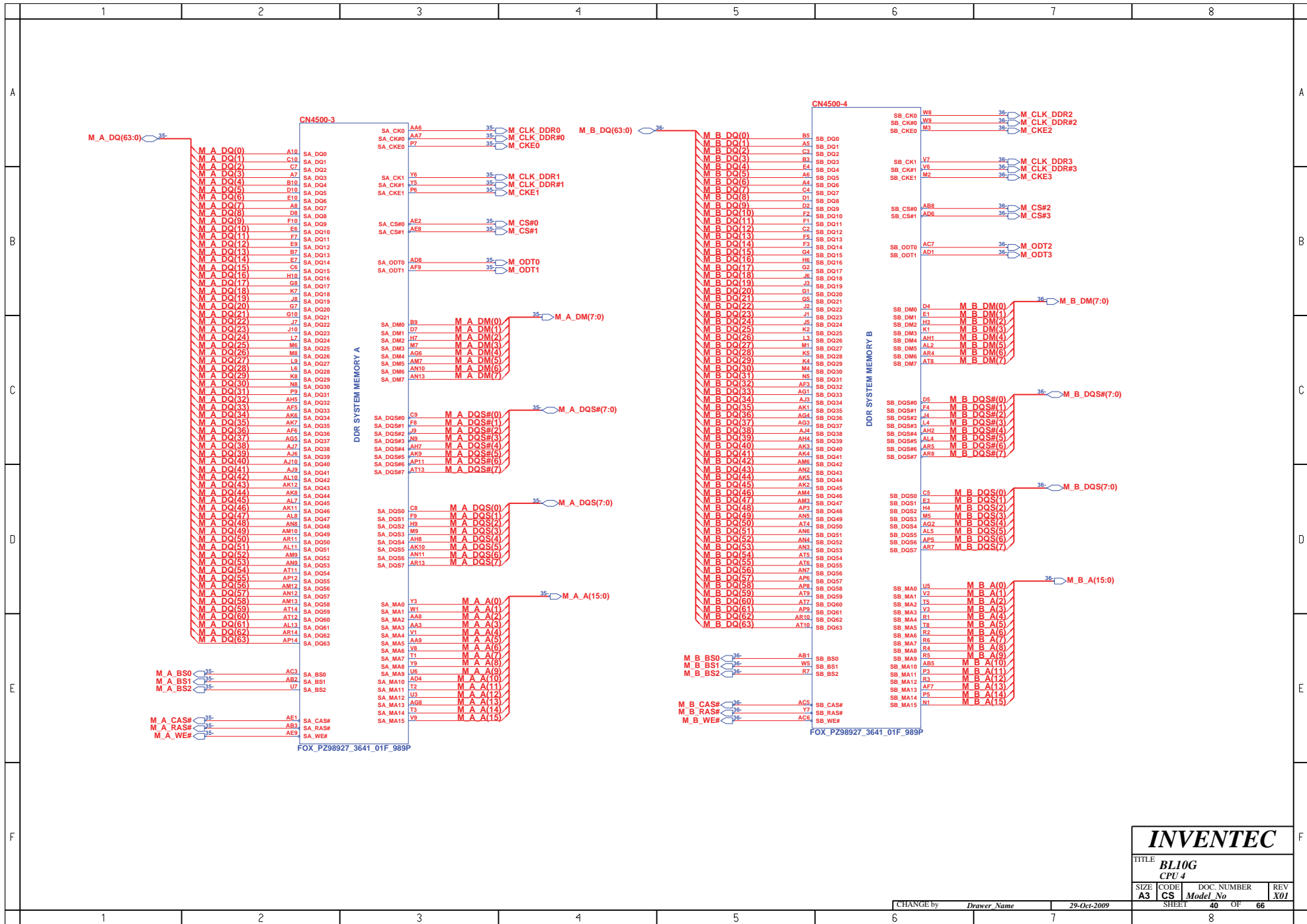

<b>INVENTEC</b>			
TITLE <b>BLI0G CPU 4</b>			
SIZE <b>A3</b>	CODE <b>CS</b>	DOC. NUMBER <i>Model No</i>	REV <b>X01</b>
CHANGE by <i>Drawer Name</i>		29-Oct-2009	SHEET 40 OF 66



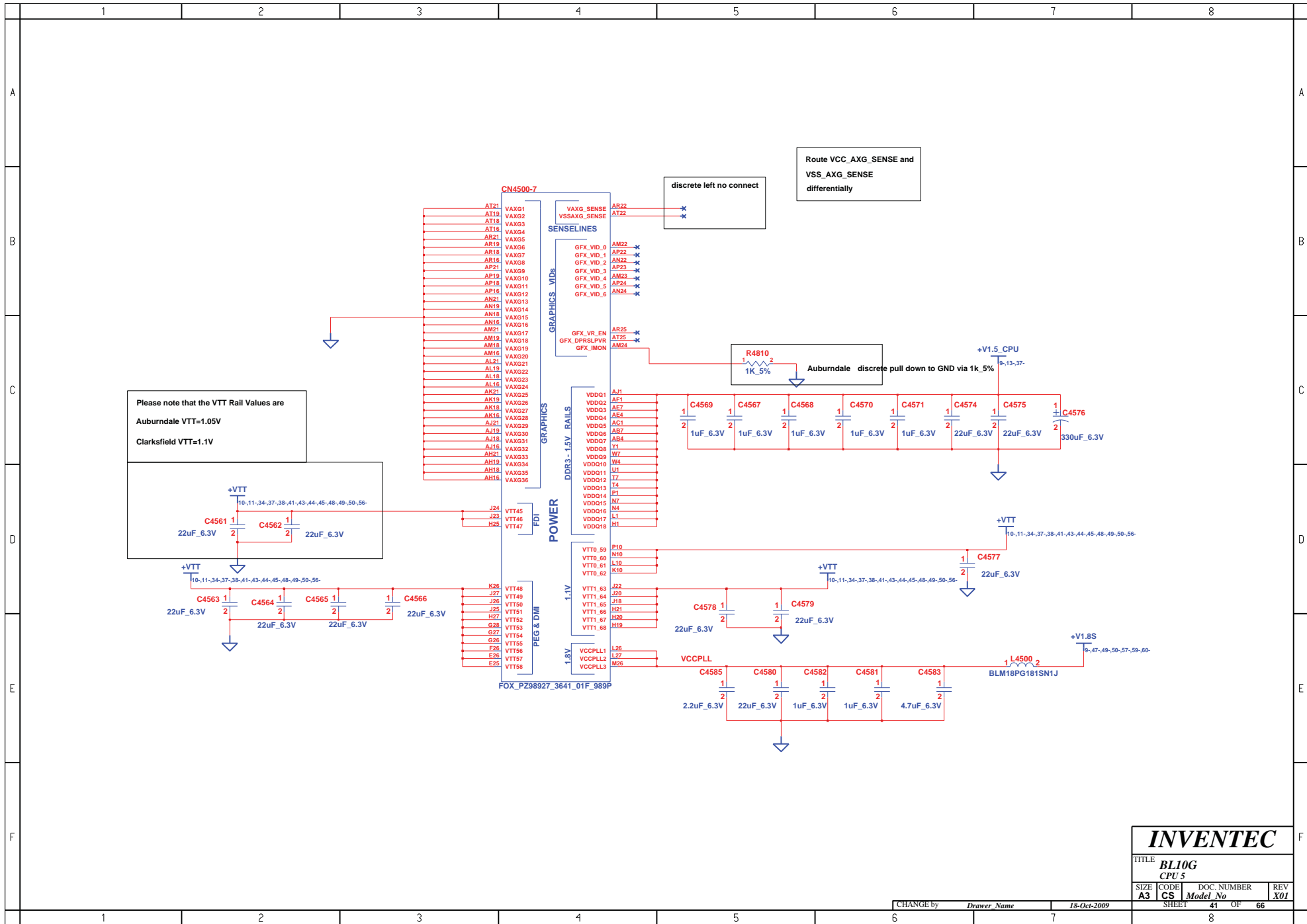

<b>INVENTEC</b>			
TITLE <b>BLI0G CPU 5</b>			
SIZE <b>A3</b>	CODE <b>CS</b>	DOC. NUMBER <i>Model No</i>	REV <b>X01</b>
CHANGE by <i>Drawer Name</i>		18-Oct-2009	SHEET 41 OF 66

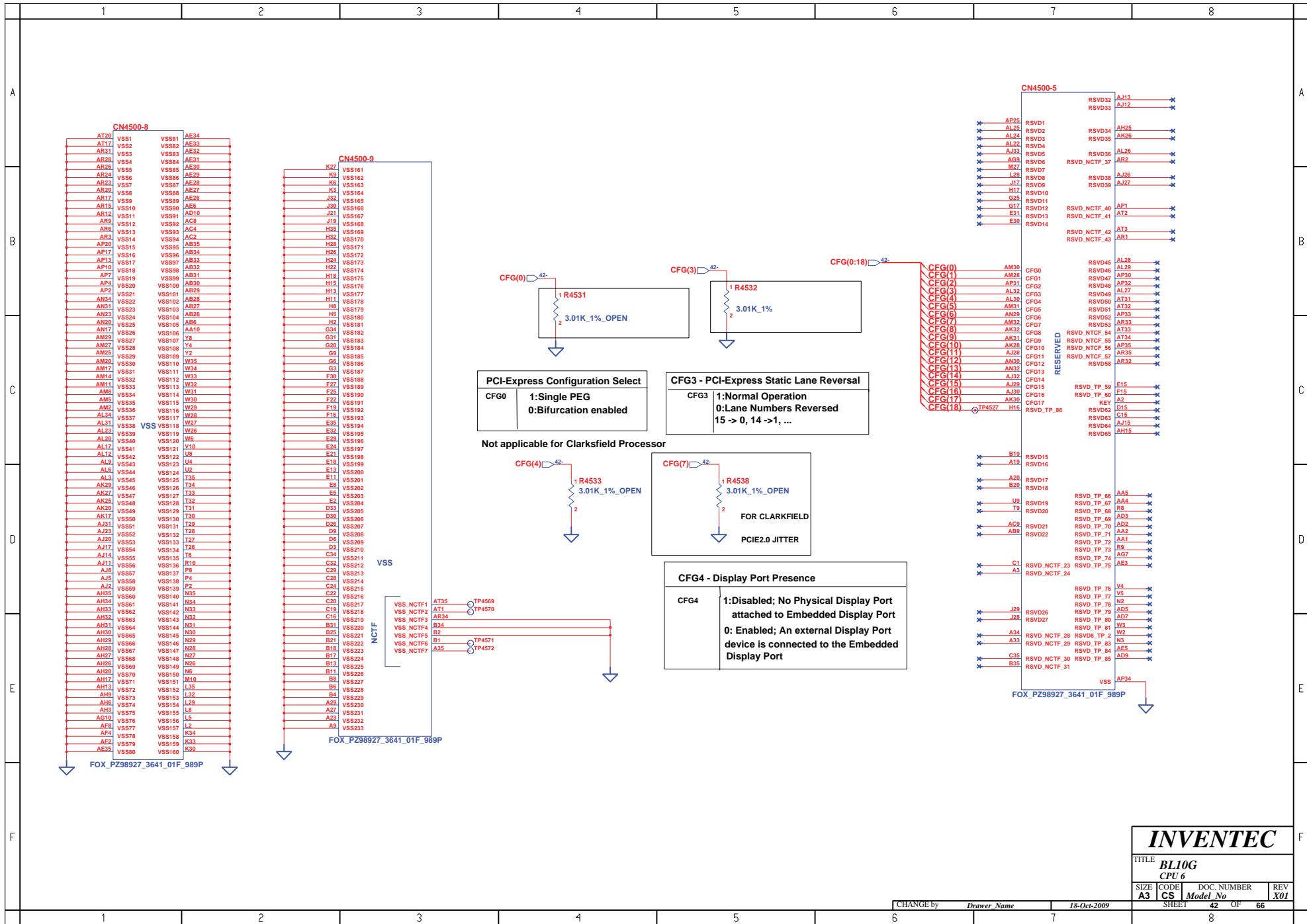

<b>INVENTEC</b>				
TITLE <b>BLI0G CPU 6</b>				
SIZE <b>A3</b>	CODE <b>CS</b>	DOC. NUMBER <i>Model No</i>	REV <b>X01</b>	
CHANGE by <i>Drawer Name</i>		18-Oct-2009		
		SHEET 42 OF 66		

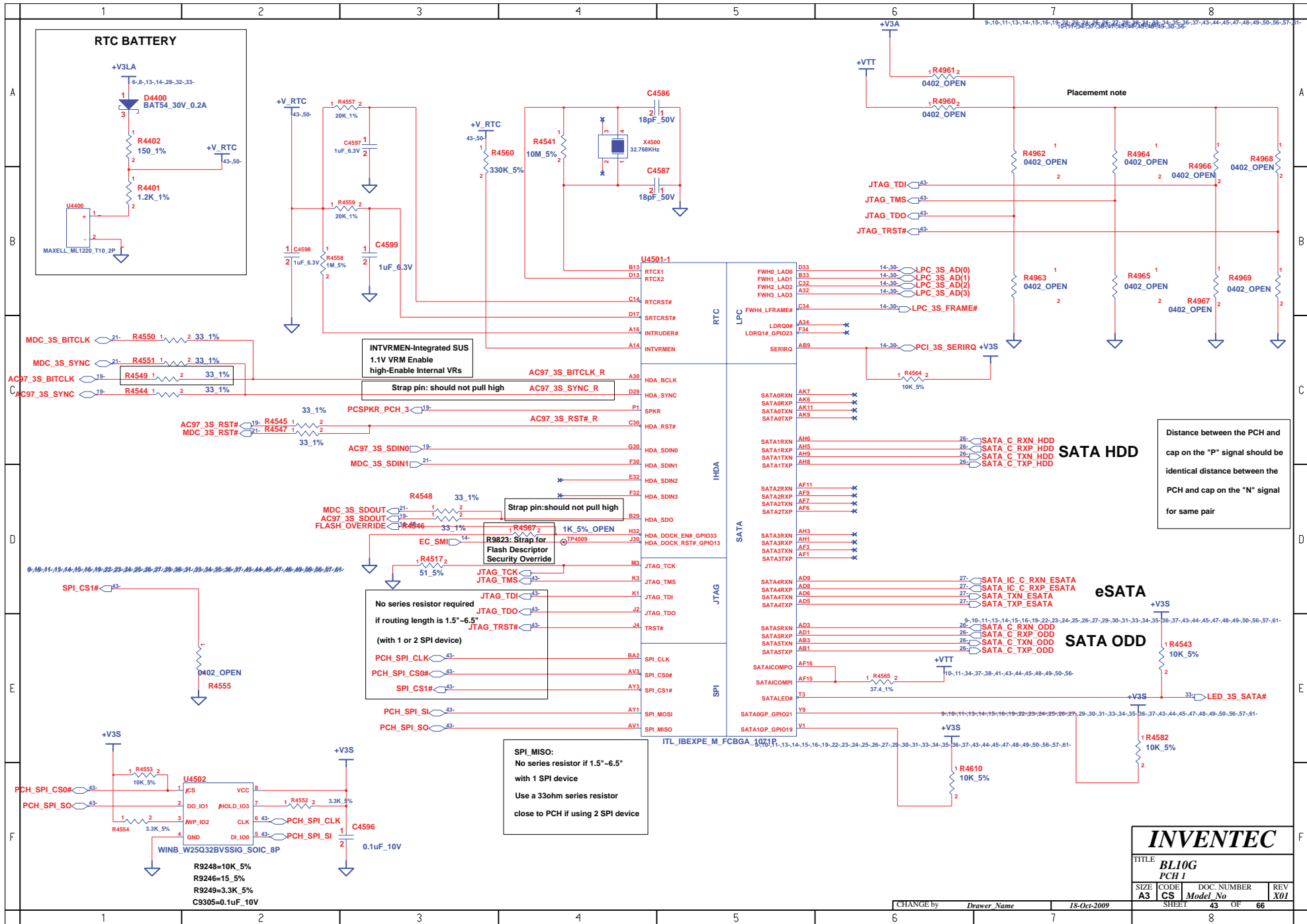



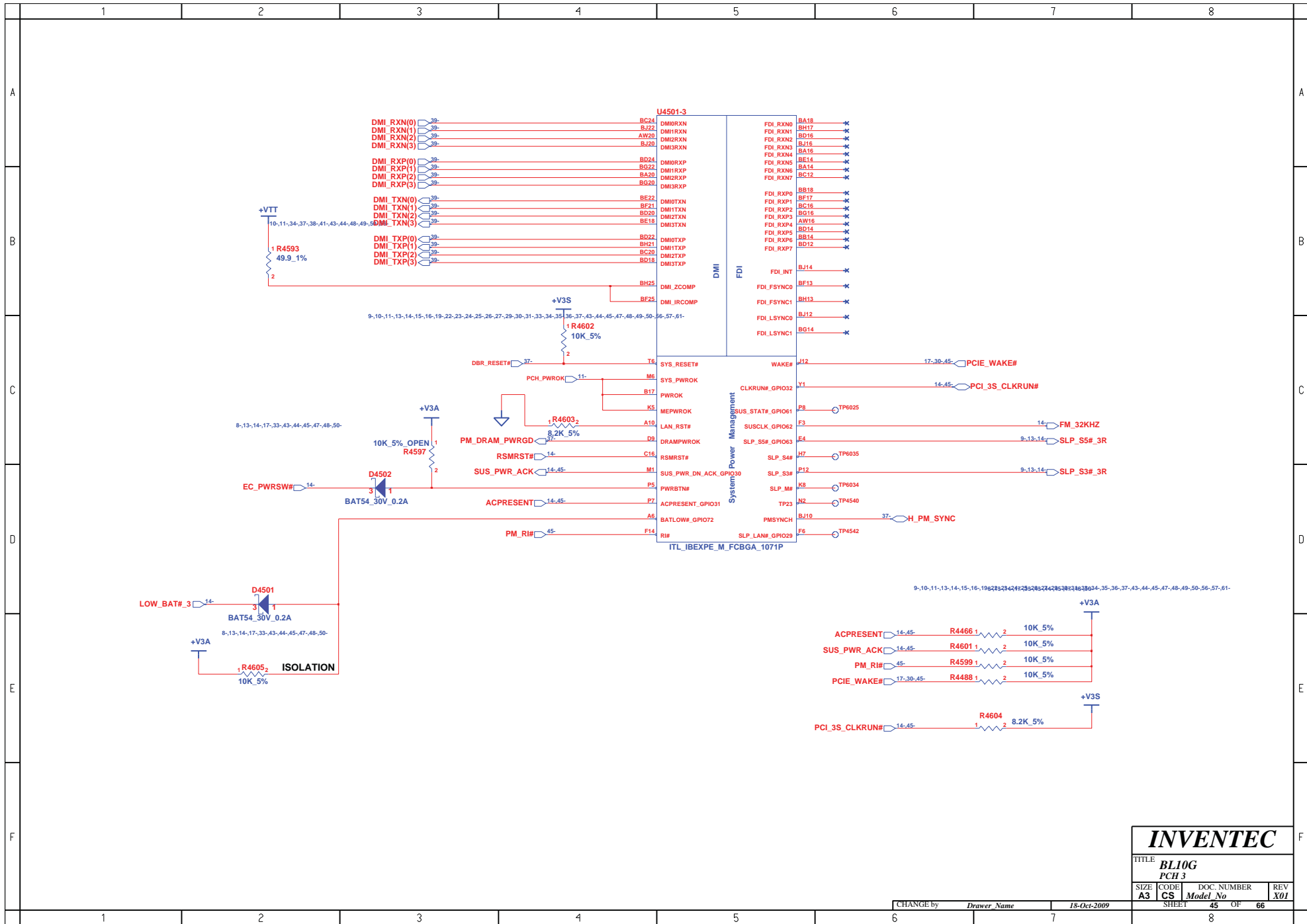

<b>INVENTEC</b>			
TITLE <b>BLI0G</b>			
PCH 3			
SIZE <b>A3</b>	CODE <b>CS</b>	DOC. NUMBER Model No	REV <b>X01</b>
CHANGE by Drawer Name		18-Oct-2009	SHEET 45 OF 66

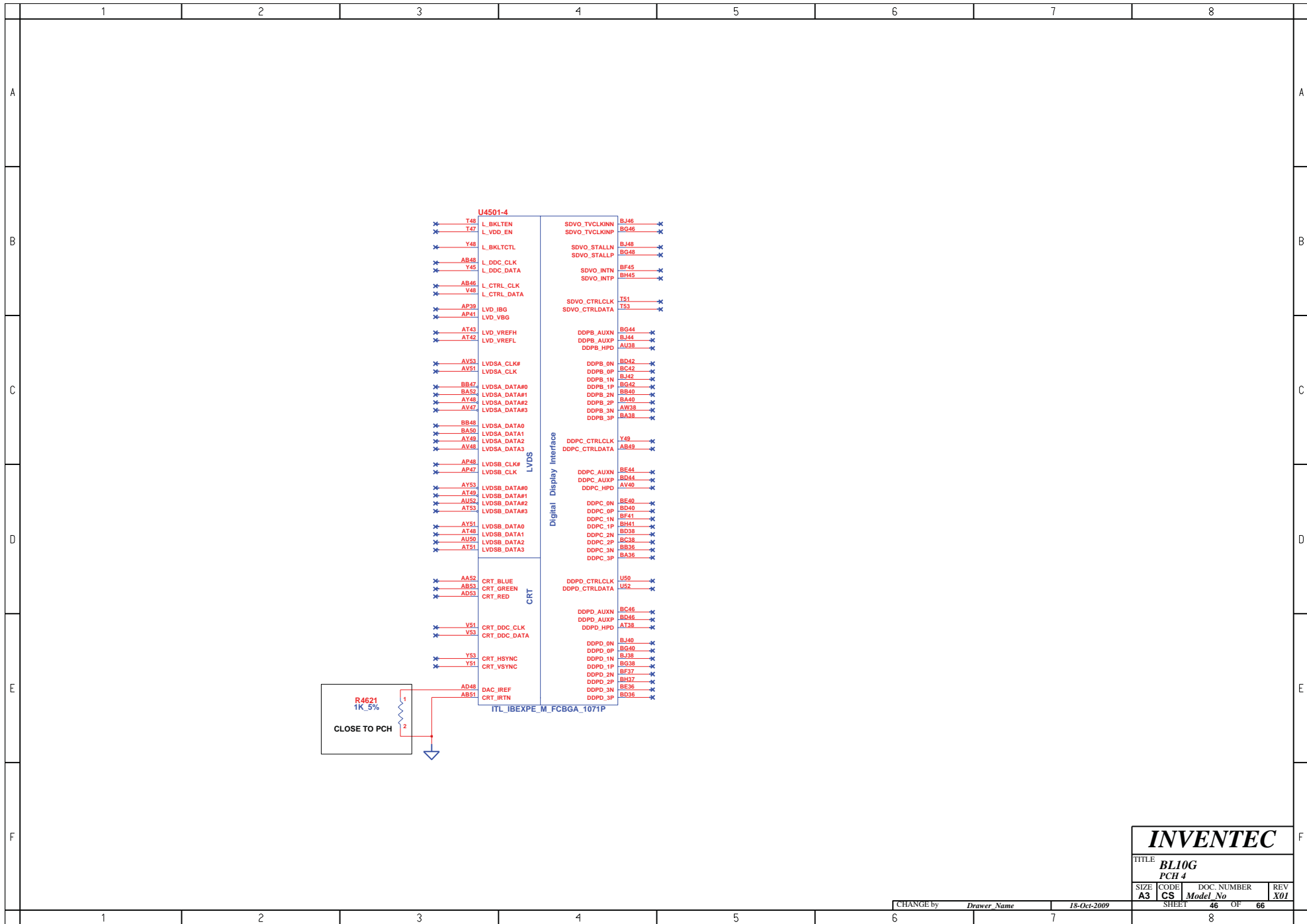

CHANGE by	Drawer Name	18-Oct-2009
-----------	-------------	-------------

<b>INVENTEC</b>			
TITLE <b>BLI0G</b> <b>PCH 4</b>			
SIZE <b>A3</b>	CODE <b>CS</b>	DOC. NUMBER <i>Model No</i>	REV <b>X01</b>
SHEET		46	OF 66

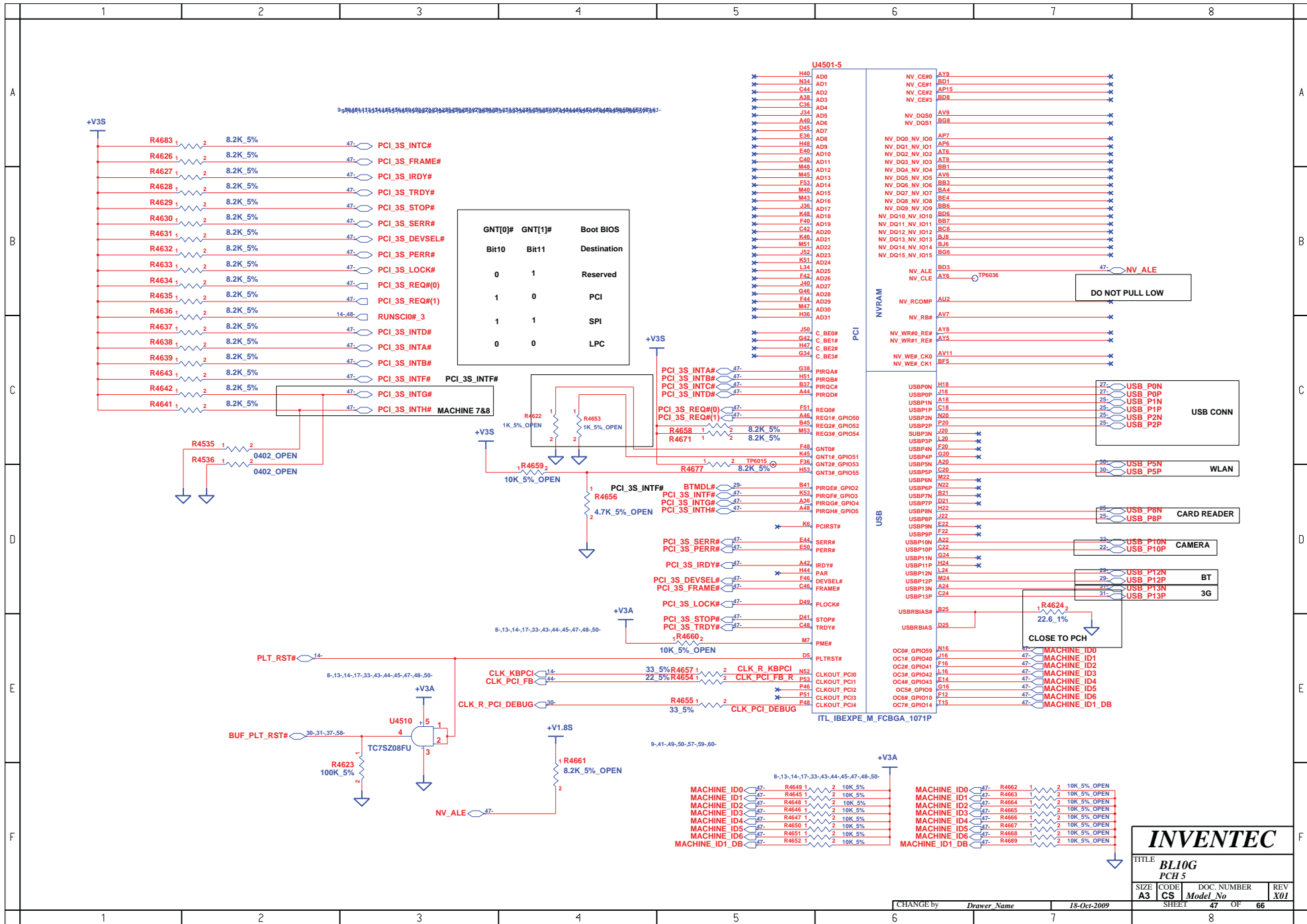

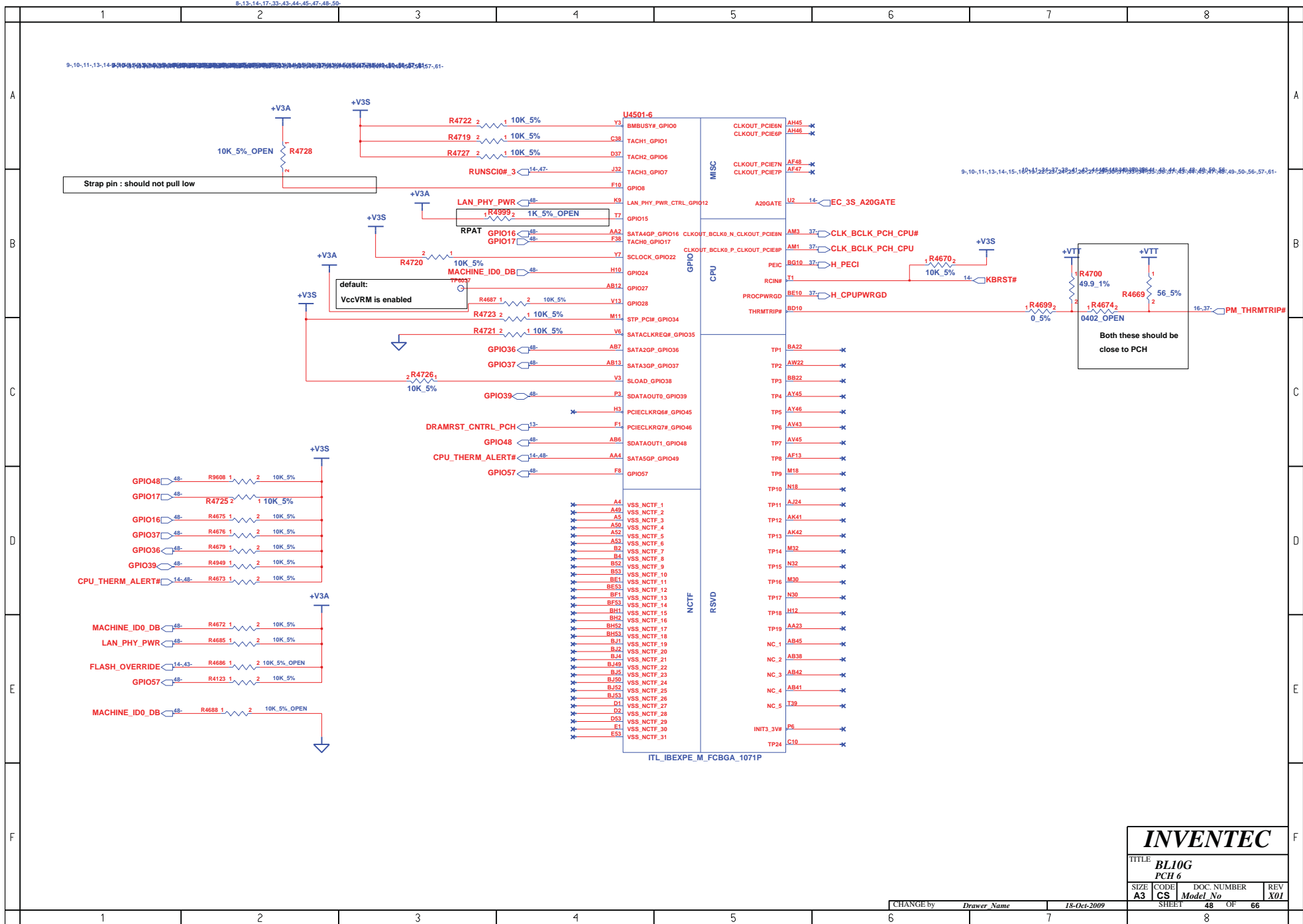

# INVENTEC

TITLE			
BL10G			
PCH 6			
SIZE	CODE	DOC. NUMBER	REV
A3	CS	Model No	X01
SHEET		8	OF 66

CHANGE by *Drawer Name* 18-Oct-2009



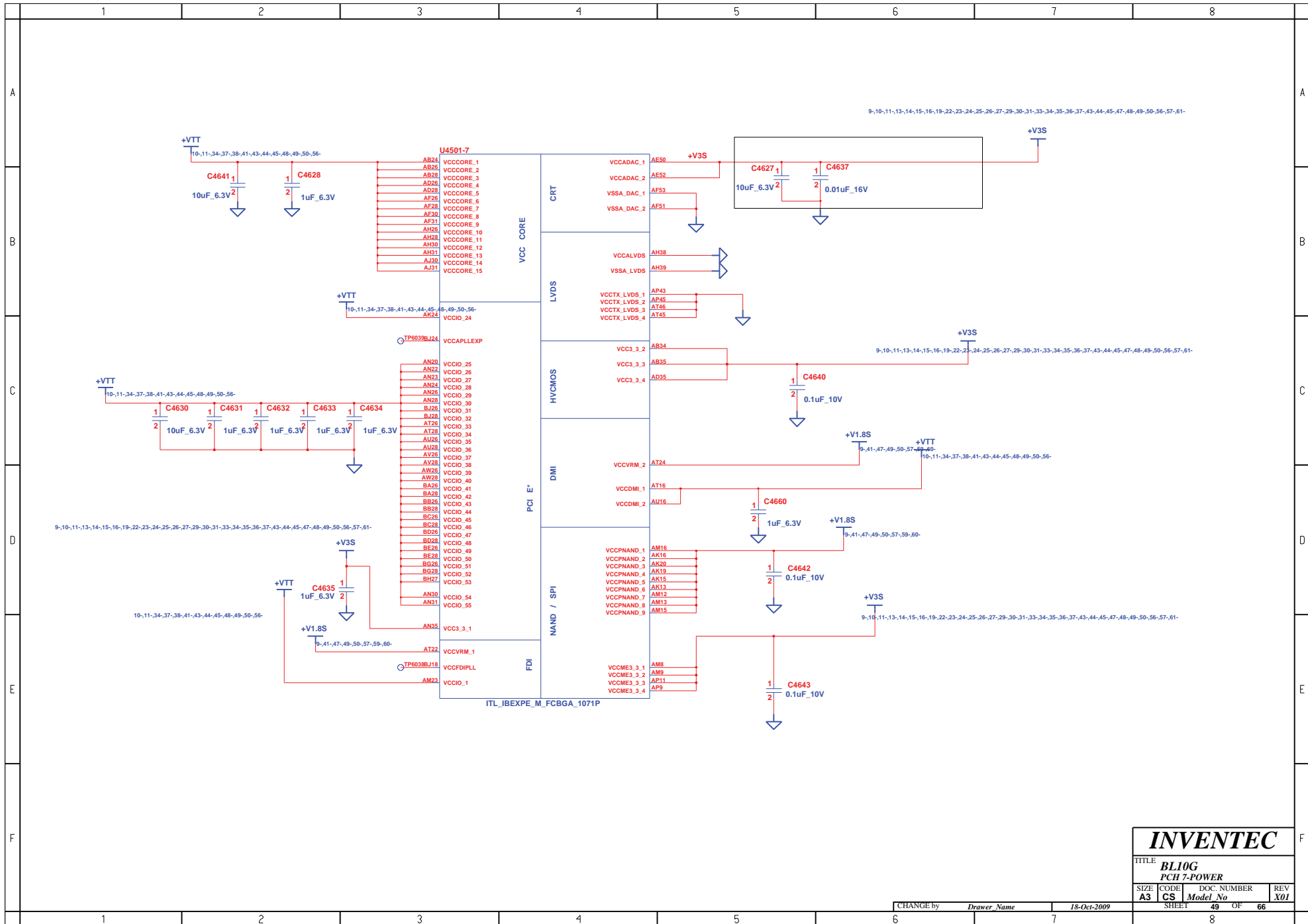

**INVENTEC**

TITLE			
BLI0G			
PCH 7-POWER			
SIZE	CODE	DOC. NUMBER	REV
A3	CS	Model No	X01
SHEET		49	OF 66

CHANGE by *Drawer Name* 18-Oct-2009



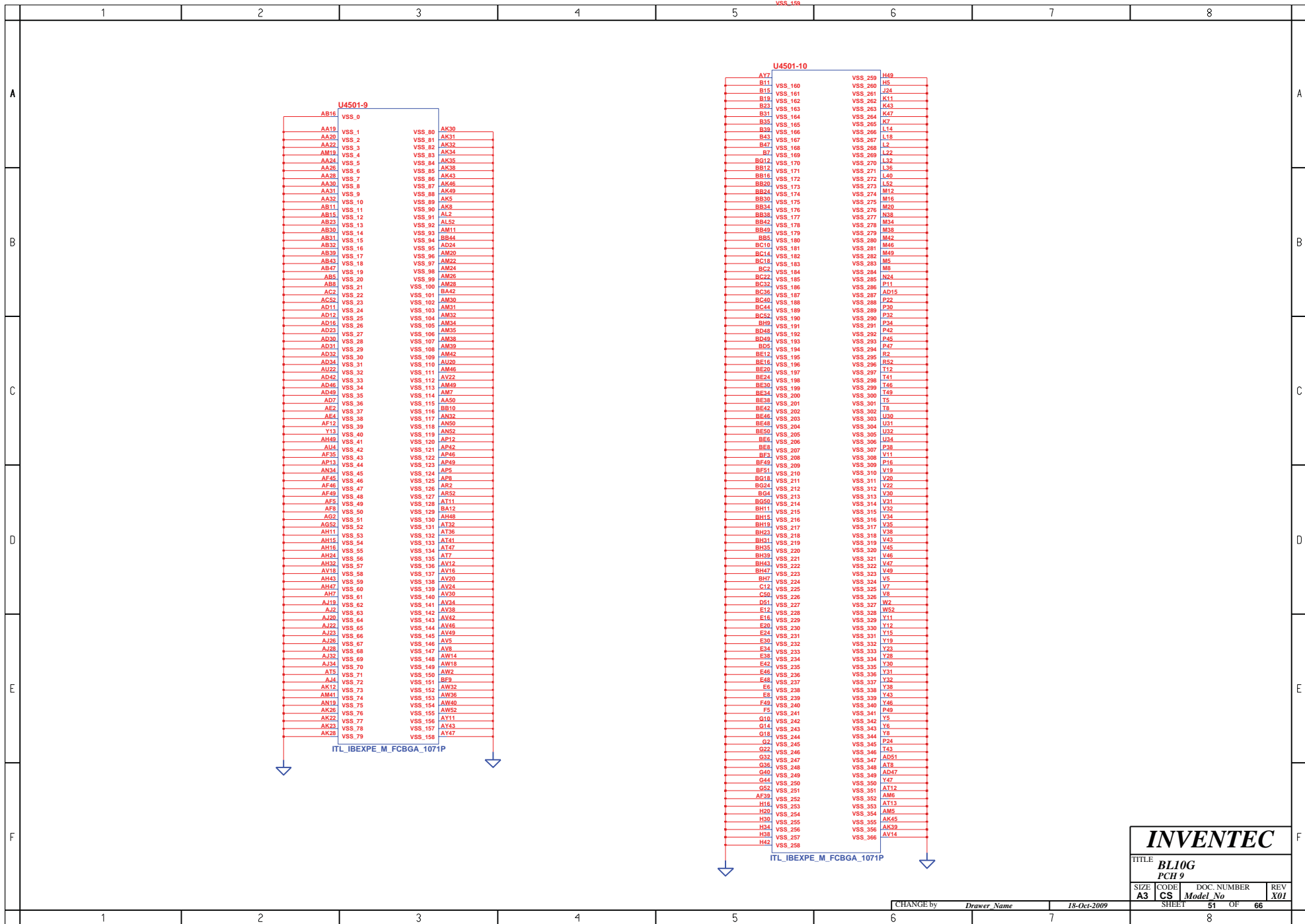

# PICK BUTTON BOARD

(For - Touchpad Module, Touchpad Switch Board, Fingerprint Module)

## Connect to Touchpad Module

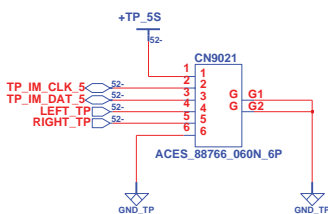

## Connect to Mainboard's TP connector

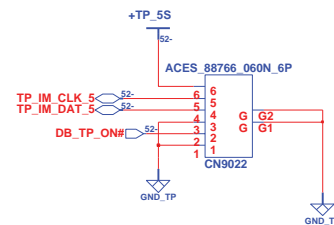

## Connect to Touchpad Switch Board

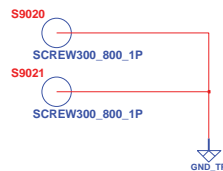
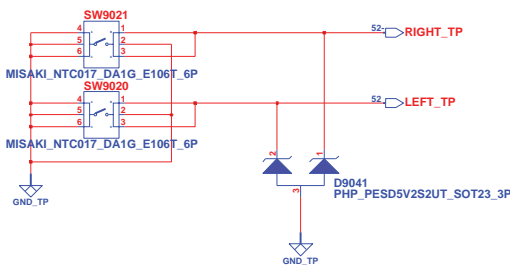
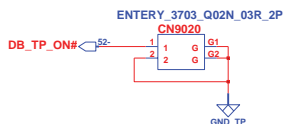

**INVENTEC**

TITLE			
BL10G			
Hot key board			
SIZE	CODE	DOC. NUMBER	REV
A3	CS	Model No	X01
SHEET		OF	66
52		8	

CHANGE by *Drawer Name* 18-Mar-2010

# TOUCHPAD SWITCH BOARD

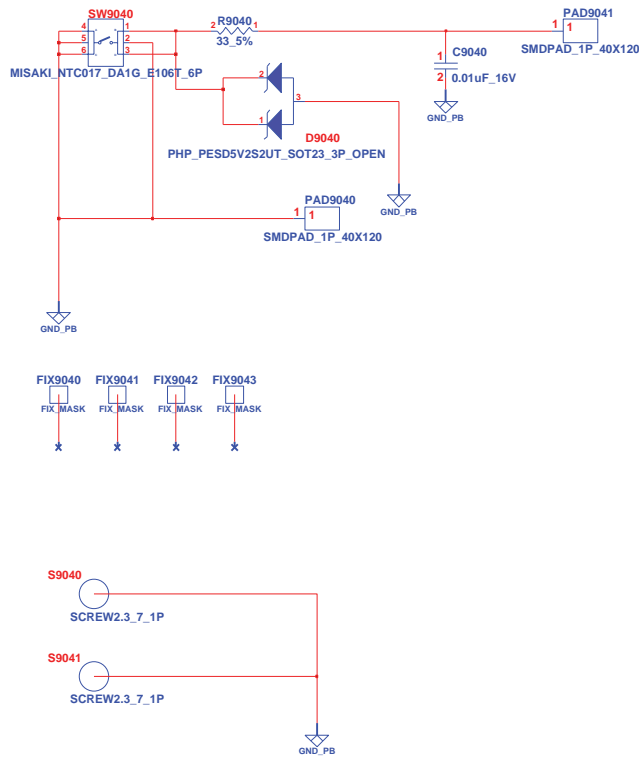

**INVENTEC**

TITLE			
BL10G			
Touch pad			
SIZE	CODE	DOC. NUMBER	REV
A3	CS	Model No	X01
SHEET		53 OF	66
		8	

CHANGE by *Drawer Name* 20-Jan-2010

# POWER BUTTON

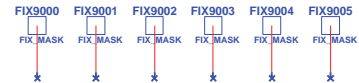
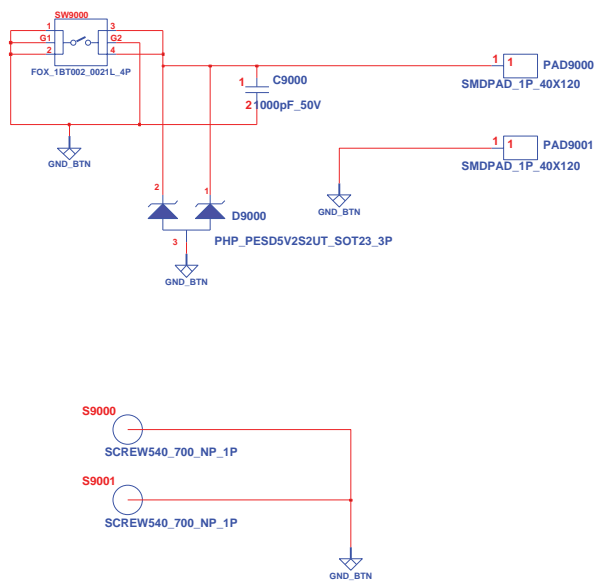

**INVENTEC**

TITLE  
**BL10G**

SIZE <b>A3</b>	CODE <b>CS</b>	DOC. NUMBER <i>Model No</i>	REV <b>X01</b>
CHANGE by <i>Drawer Name</i>		11-Mar-2010	
SHEET			8 OF 66

# CARD READER & USB BOARD

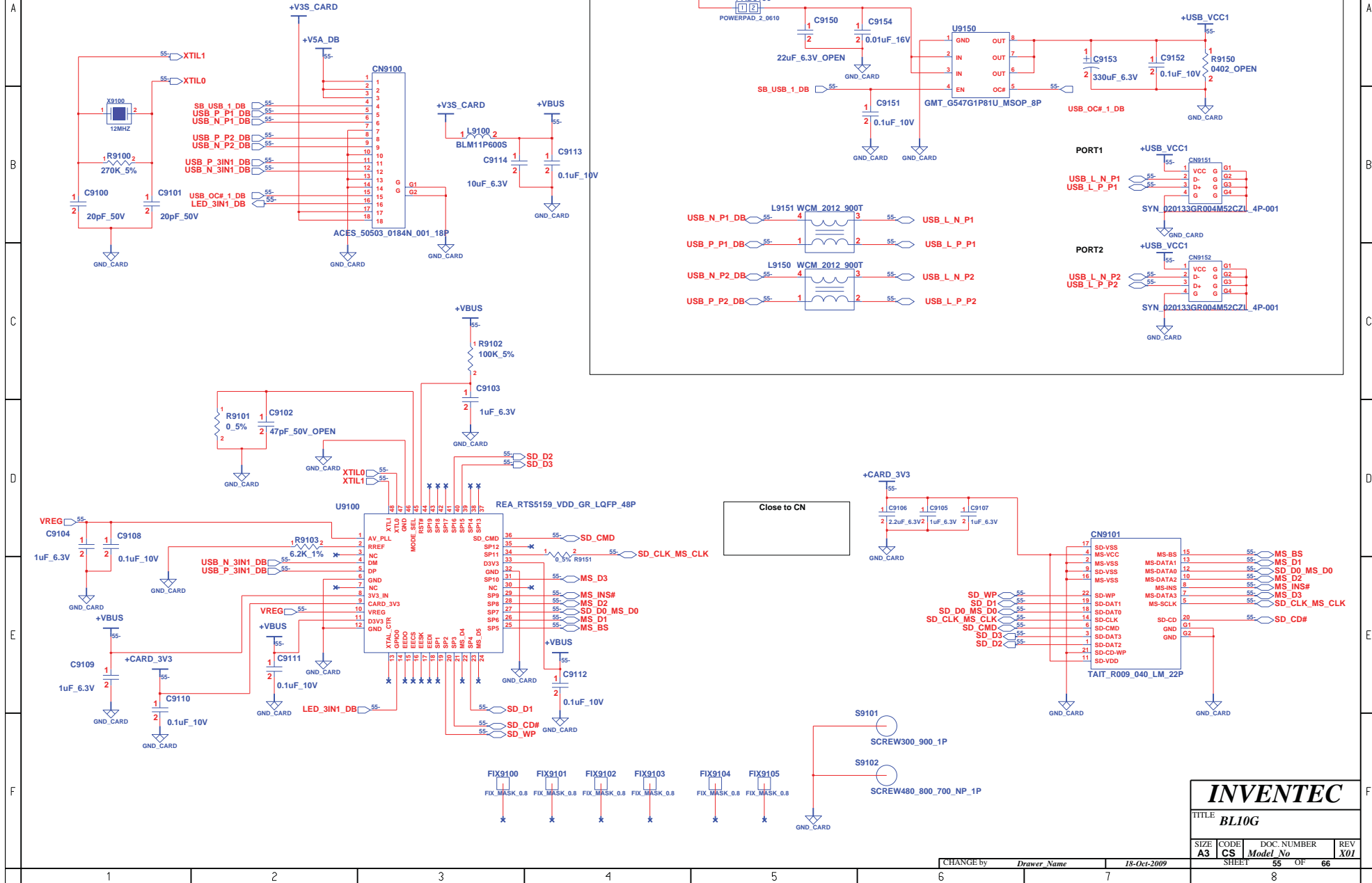

<b>INVENTEC</b>			
TITLE BLI0G			
SIZE A3	CODE CS	DOC. NUMBER Model No	REV X01
CHANGE by Drawer Name		18-Oct-2009	
SHEET 55		OF 66	
		8	





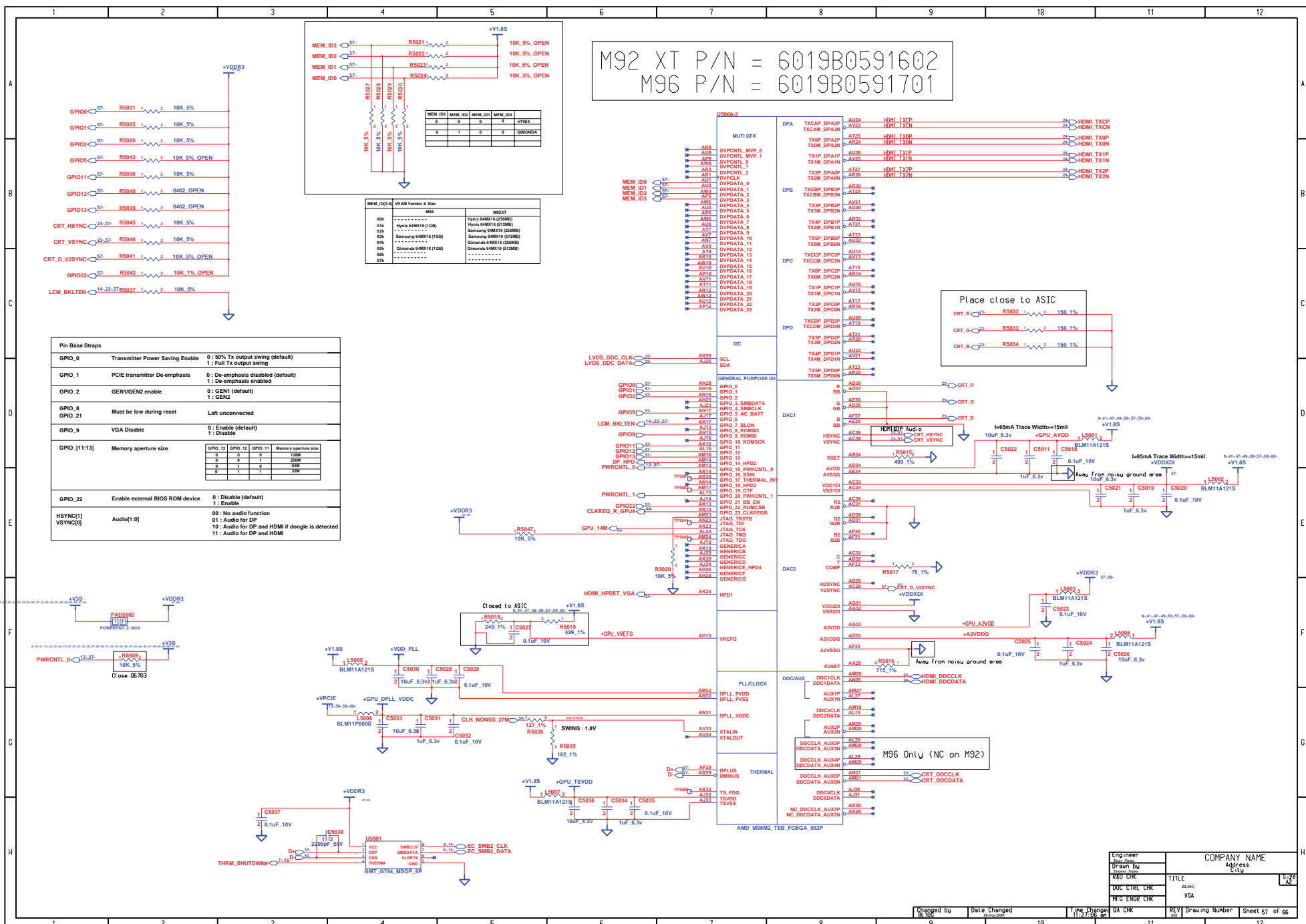

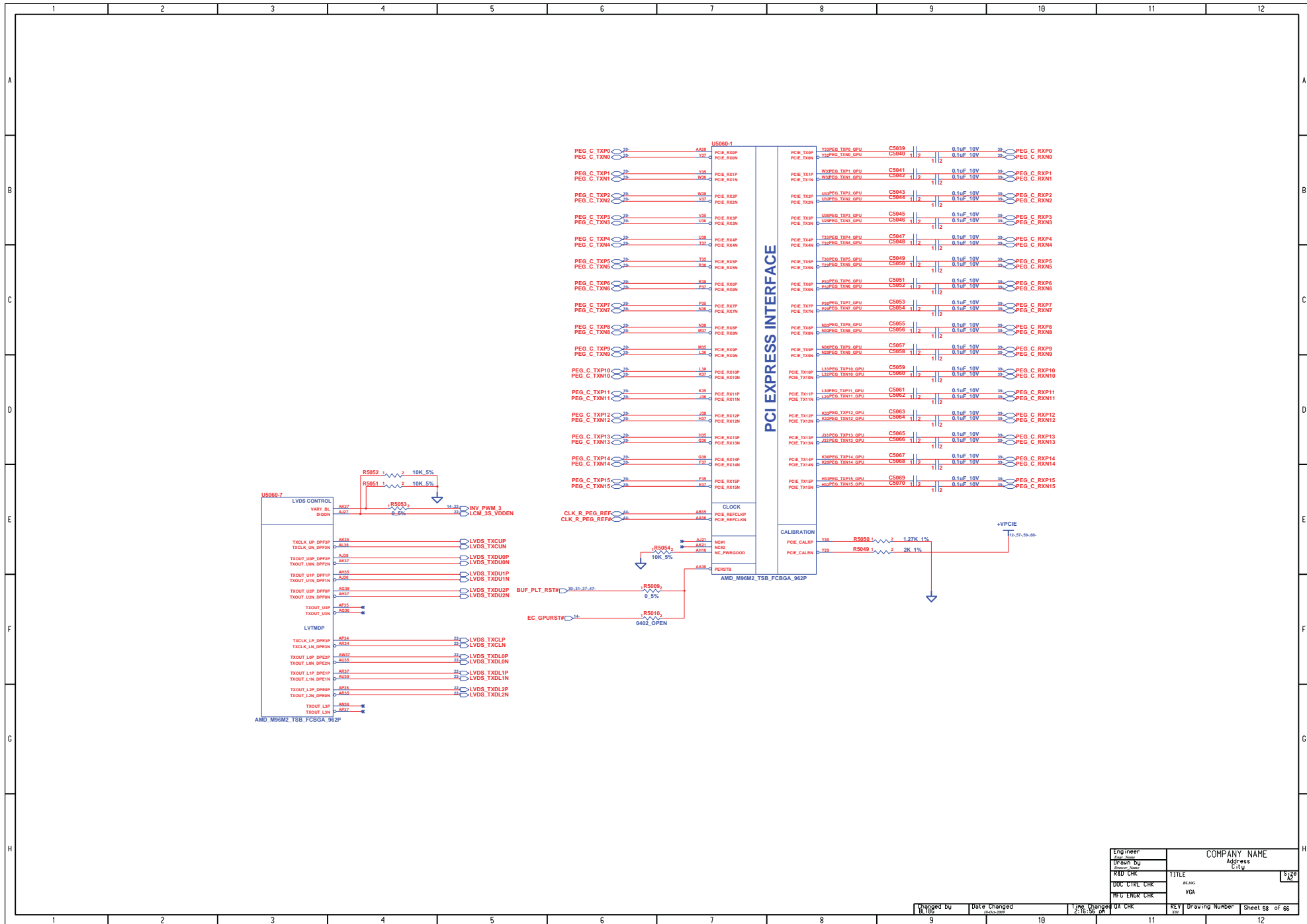

Engineer	COMPANY NAME
TR Desig. DU	Address
TR Rev. DU	City
TRM CHK	State
DOC CTRL CHK	TITLE
MFG ENGR CHK	NO. 001
	VGA

Checked by	Date Changed	Time Changed	UA CHK	REV	Drawing Number	Sheet 58 of 66
------------	--------------	--------------	--------	-----	----------------	----------------

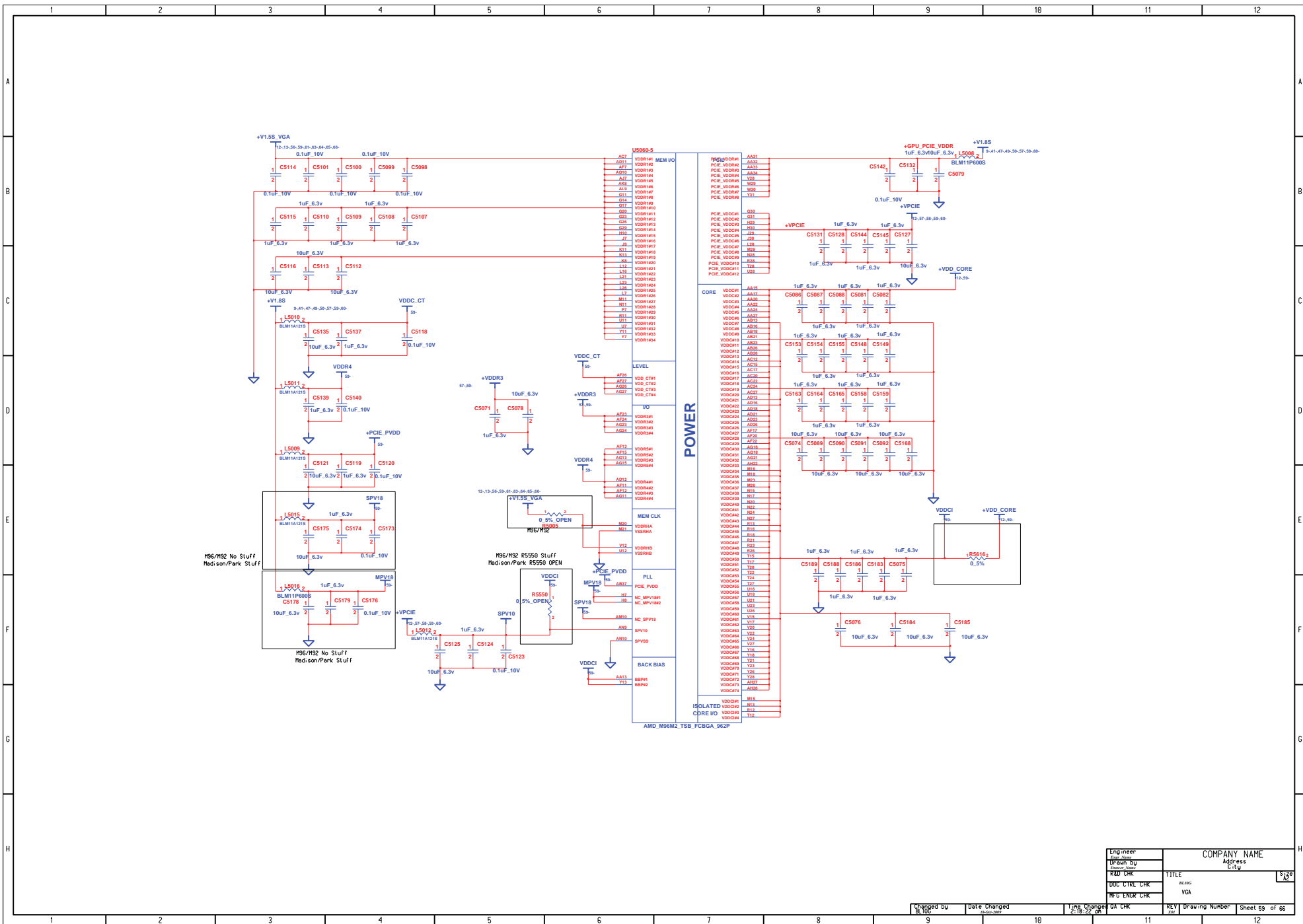

H96/M92 No Stuff  
Madison/Park Stuff

M96/M92 R5550 Stuff  
Madison/Park R5550 OPEN

H96/M92 No Stuff  
Madison/Park Stuff

Engineer	COMPANY NAME
TR Desig. DU	Address
Power	City
PLD CLK	State
DDC CTRL CLK	TITLE
MPU ENGR. CLK	REV
	VGA
Checked by	Date Changed
1 mg	1 mg
UA CHK	REV
1 mg	Drawing Number
	Sheet 59 of 66

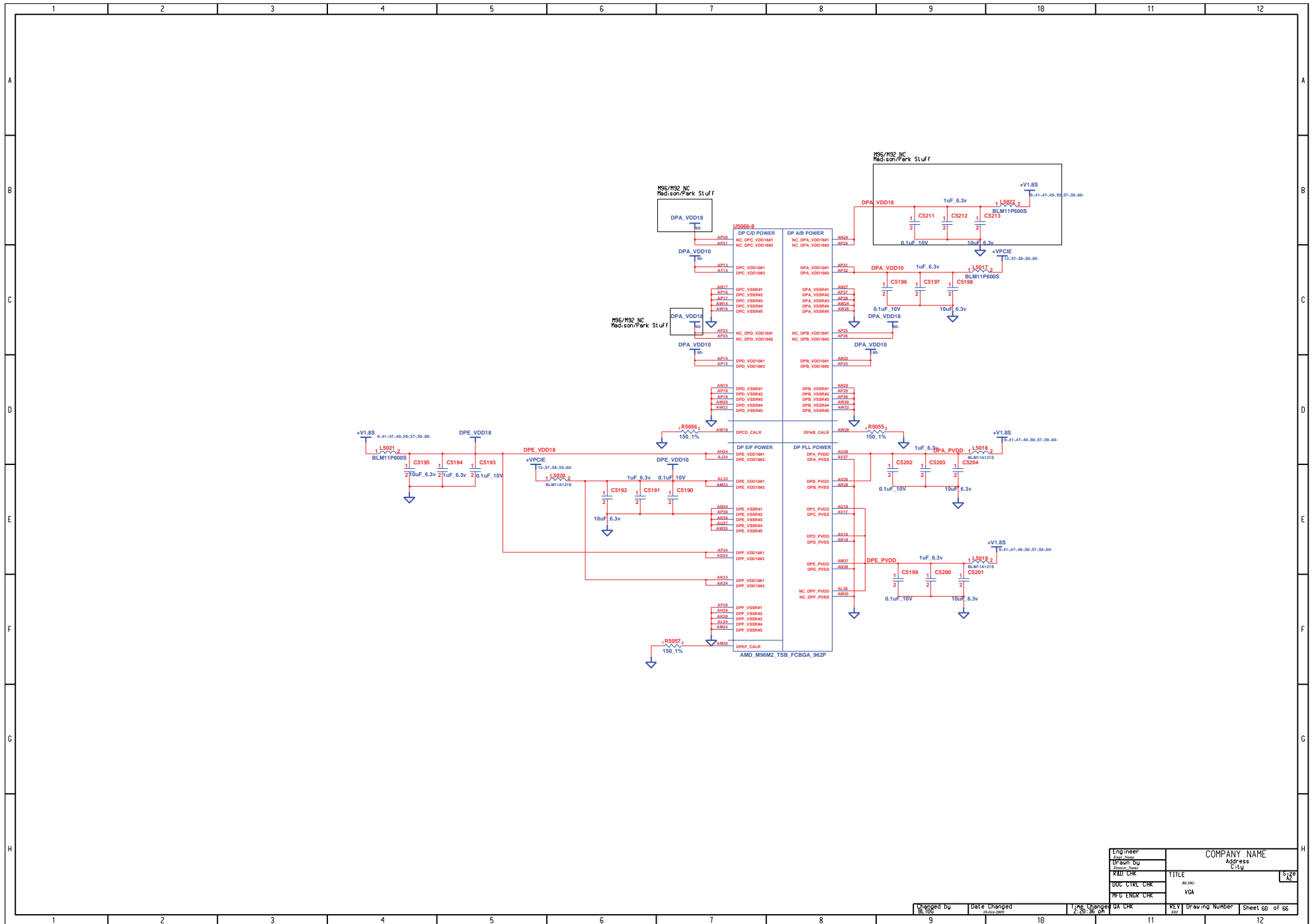



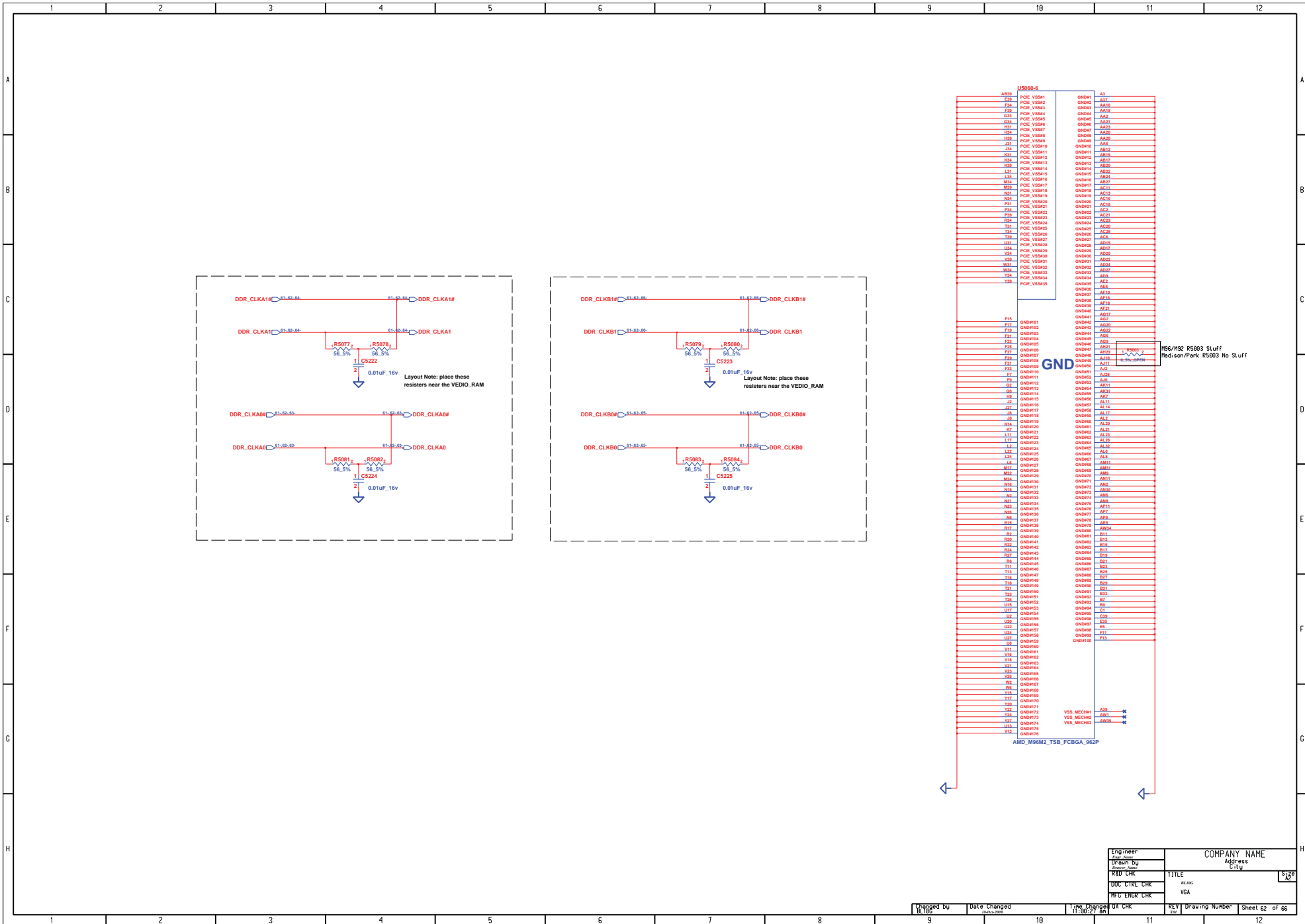







## M92 Use channel B

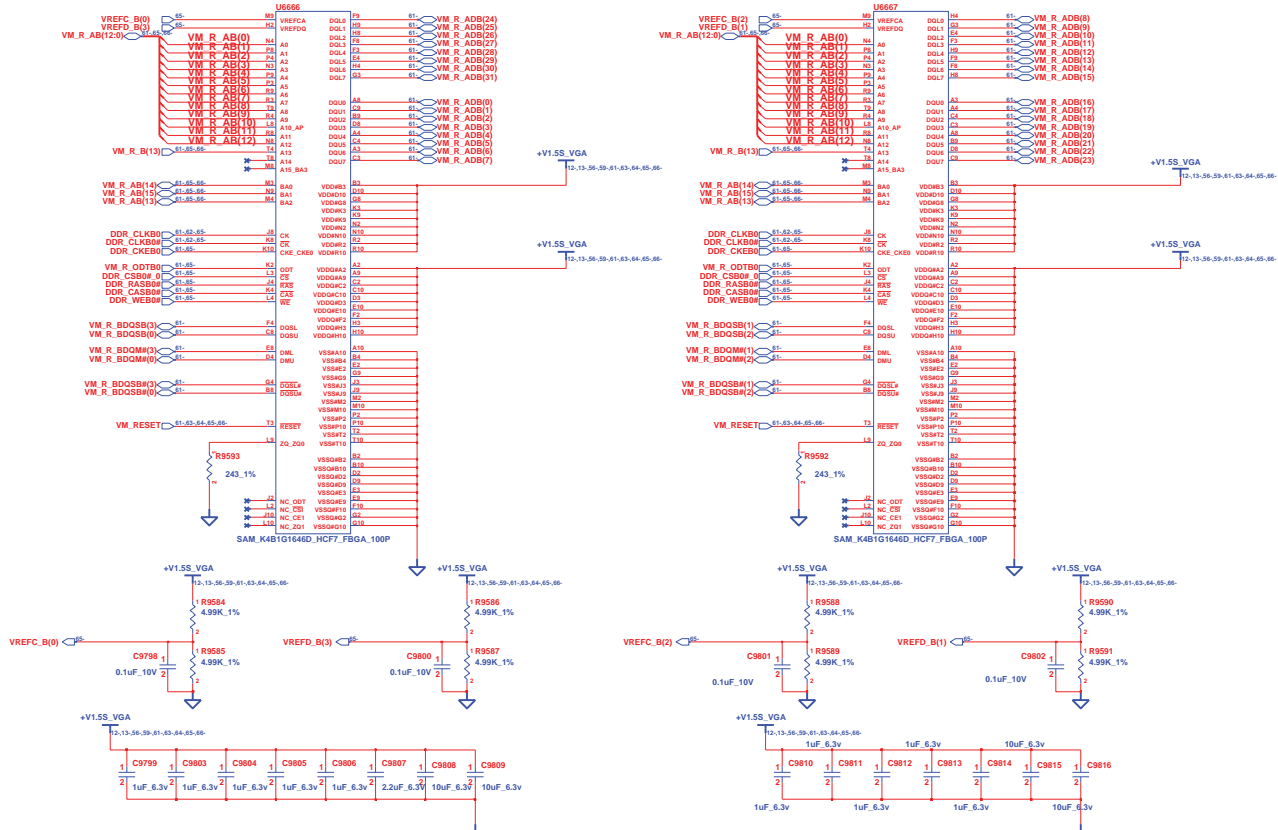

Engineer	COMPANY NAME
TR Des: DU	Address
TR Rev: 00	City
DOC ENGR CHK	TITLE
MFG ENGR CHK	Address
	City
	State
	Country
Checked by	Date Changed
Trng. Checked by	Date Changed
UA CHK	REV
	Drawing Number
	Sheet 65 of 66

